

MOTOR	L (Unit: mm)
TSM34x-1AG	112.5
TSM34x-3AG	143
TSM34x-5AG	172.5
TSM34x-6AG	203

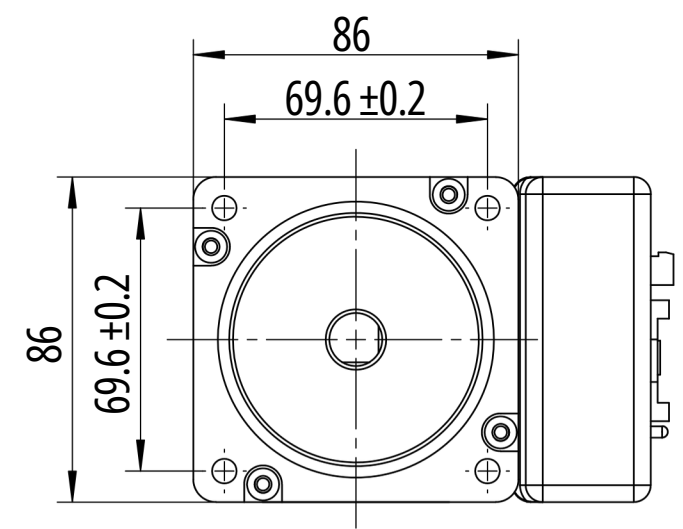
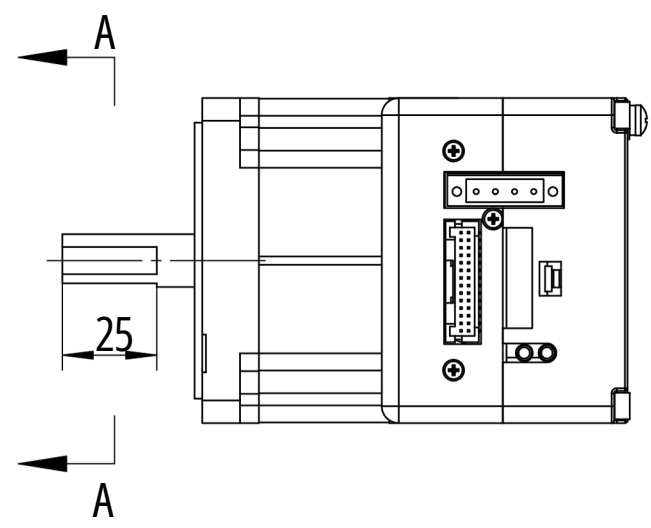
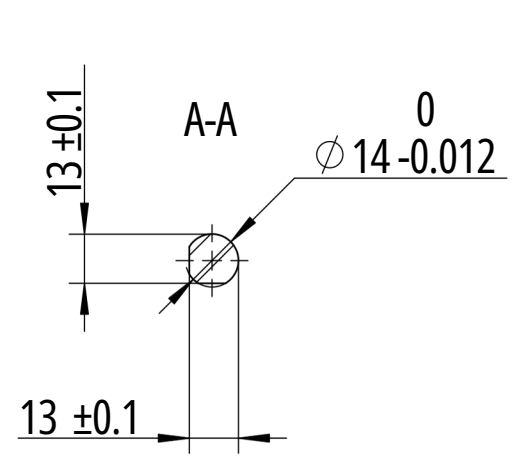

Allowable tolerance range				TSM34 RS232		
Decimals: mm X.XXX = ± 0.01 X.XX = ± 0.10 X.X = ± 0.20 x = ± 0.50	A0	Change		Drawing stage	Weight	Scale
	Mark	Order No.	Date			
	Design	Process		D		
	Check	Verify		Sheet	1/1	
	Approve					