

M2DC Series DC Servo System



Hardware Manual
Rev. 1.1

SHANGHAI AMP&MOONS' AUTOMATION CO.,LTD.

Table of Contents

1 Introduction	8
1.1 About This Manual	8
1.2 Documentation Set for the M2DC Series Servo Drive	8
1.3 Safety	8
1.4 Safety Symbols	8
1.5 Safety Instructions.....	9
1.6 Guideline for Parts Replacement	9
1.6.1 Parts Replacement.....	9
1.6.2 Bearing Life	10
1.7 Standards Compliance.....	11
2 Product Description.....	12
2.1 System Checklist.....	12
2.2 Servo Drive Model Introduction	12
2.2.1 Drive Name Plate Description	12
2.2.2 Drive Model Description	12
2.2.3 Drive specifications	13
2.2.4 Drive Dimensions (Unit: mm)	14
□ M2DC-20D	14
2.3 Servo Motor Model Introduction	15
2.3.1 Motor Name Plate Description	15
2.3.2 Motor Model Description	15
2.3.3 Motor Specifications and Dimensions	16
2.3.3.1 40mm Specifications and Dimensions	16
2.3.3.2 60mm Specifications and Dimensions	18
2.3.3.3 80mm Specifications and Dimensions	20
2.4 Servo Drive and Servo Motor Combinations	23
3 Installation.....	24
3.1 Storage Conditions.....	24
3.2 Installation Conditions	24
3.3 Installation Space.....	25
3.4 Motor Installation.....	26
4 Connections and Wiring	27
4.1 Connecting to Peripheral Devices.....	27
4.1.1 System Configuration	27
4.1.2 Servo Drive Connectors and Terminals.....	28
4.1.3 Connections and Wiring Notes.....	28
4.1.4 Wiring Methods for P1 Power Supply Connector	29
4.2 Wiring to the P2 Connector	30
4.2.1 Motor Power Cable Configuration	30

4.2.2 Motor Power Cable Connector(-CD Winding ,6Amps)	30
4.2.2.1 PIN Assignment.....	30
4.2.2.2 Motor Connector Specifications	30
4.2.2.3 Motor Extension Cable Wiring Diagram	31
4.2.3 Motor Power Cable Connector(-CF Winding,10 and 20Amps)	31
4.2.3.1 PIN Assignment.....	31
4.2.3.2 Motor Extension Cable Wiring Diagram	32
4.3 Encoder Connector CN3	33
4.3.1 Motor Encoder Feedback Cable Configuration	33
4.3.2 Layout of CN3 Connector.....	33
4.3.3. Connection to Motor Encoder.....	34
4.3.4 Specifications of Encoder Connector	34
4.3.5 Motor Encoder Extension Cable Wiring Diagram.....	35
4.4 STO Connector	36
4.4.1 Safety Precautions	36
4.4.2 STO Input/Output Signals	36
4.4.2.1 STO Internal Circuit Diagram	36
4.4.2.2 CN5 Connector diagram.....	36
4.4.2.3 STO Signal Definition	37
4.4.2.4 STO Connection Diagrams	37
4.5 Electromagnetic Brake	38
4.5.1 Wiring Diagram.....	38
4.5.2 Brake Motor.....	38
4.5.3 Timing Charts of the Electromagnetic Brake.....	38
4.6 Regeneration Resistor.....	39
4.6.1 Recommended external resistor	39
4.6.2 Regeneration ResistorConfiguration	39
4.7 Recommended Cable Specifications	40
4.8 Connecting to the Host Computer - CN1.....	40
4.9 Input and Output Signal Interface Connector - CN2	40
4.9.1 Input and Output Interface Specifications and Diagram.....	40
4.9.2 Signal Description of Connector CN2.....	41
4.9.2.1 Layout of CN2 Connector.....	42
4.9.2.2 Input Signals.....	42
4.9.2.3 Input Function List.....	43
4.9.2.4 Output Signals.....	44
4.9.2.5 Output Function List	44
4.9.3 Input Signal Interface Connector, CN2.....	45
4.9.3.1 Position pulse signal input.....	45
4.9.3.2 Analog Signal Input For Velocity And Torque Mode	46
4.9.3.3 High Speed Input Ports X1, X2, X3, X4.....	47
4.9.3.4 General Digital Input X5, X6, X7, X8.....	49
4.9.3.5 X9, X10, X11, X12 Inputs with common COM Port.....	51

4.9.4	CN2 Output Signal Specification	52
4.9.5	Encoder Feedback Output	53
4.9.5.1	A/B/Z Connection Diagram	53
4.9.5.2	Z Phase Open Collector Output	53
5	Display and Operation	54
5.1	Control Panel Description	54
5.2	Mode Switch Control	55
5.3	LED display description	56
5.3.1	Decimal Point And Negative Sign Description	56
5.3.2	Parameter View Setting	56
5.3.3	Parameter Save Setting	56
5.3.4	Point To Point Motion Mode	57
5.3.5	Jog Mode	57
5.3.6	Control Panel Lock	57
5.4	Status Monitoring Selection Mode	58
5.5	Function Control Mode	60
5.5.1	Function Mode Description	60
5.5.2	Operation Flow Chart	61
5.6	Parameter Setting Mode	62
5.6.1	Parameter Setting Description	62
5.6.2	Parameter Editing Examples	63
5.7	Control Panel Lock	64
5.8	Warning And Fault Display	64
6	Preoperational mode	66
6.1	Inspection Before Trial Run	66
6.2	Trial Run Procedure	66
6.3	Motor Configuration	67
6.3.1	Using the Drive Control Panel for configuration	67
6.3.2	Using M Servo Suite Software for configuration	68
6.4	Operations of JOG Mode	69
6.5	Configuration by Personal Computer	70
7	Operation Mode Selection	71
7.1	General Function Settings	71
7.1.1	Drive Servo On Settings	71
7.1.2	Alarm Reset	72
7.1.3	CW/CCW limit	73
7.1.4	Global Gain Selection	74
7.1.5	Control Mode Selection	75
7.1.6	Drive On Fault Output	76
7.1.7	Motor Brake Control	77
7.1.8	Servo Ready Output	78
7.2	Position Mode	79

7.2.1 Digital Pulse Position Mode Connection Diagram.....	79
7.2.2 Input Pulse Type And Input Noise Filter	80
7.2.3 Control Pulse Dividing Switch	82
7.2.4 Pulse Inhibit	83
7.2.5 Electronic Gearing Ratio	84
7.2.6 Jerk Smoothing Filter	85
7.2.7 In-Position Error Output.....	85
7.2.8 Gain Parameters For Position Control Mode	86
7.2.9 Software Configuration For Position Mode.....	87
7.3 Velocity Mode	88
7.3.1 Velocity Mode Connection Diagram	89
7.3.2 Parameter Settings For Analog Velocity Control Mode	90
7.3.3 Basic Settings For Analog Velocity Control Mode	91
7.3.4 Analog Input Filter	96
7.3.5 Software Configuration for Analog Velocity Mode	97
7.4 Torque Mode	98
7.4.1 Analog Torque Mode Connection Diagram.....	99
7.4.2 Parameters For Analog Torque Mode	100
7.4.3 Basic Settings For Analog Torque Mode	101
7.4.4 Software Configuration for Analog Torque Mode.....	106
7.5 Position Table Mode	107
7.5.1 Linear motion.....	107
7.5.1.1 Linear Motion Software Configuration	107
7.5.1.2 Basic Configuration	108
7.5.1.3 Homing settings.....	109
7.5.1.4 Print	109
7.5.1.5 Position Definition.....	109
7.5.1.6 Simulate	110
7.5.1.7 Linear motion input definition	110
7.5.2 Rotary motion	111
7.5.2.1 Rotary motion software configuration.....	111
7.5.2.2 Rotary motion input definition.....	112
8 Parameters and Functions	113
8.1 Parameter Category	113
8.2 Parameter List.....	113
8.3 Parameter Description.....	118
9 Communication	140
9.1 RS-232 communication	140
9.1.1 What is SCL?	140
9.1.2 RS-232 Connections	140
9.2 RS-485 Communication	140
9.2.1 RS-485 PIN definition	140

9.2.2 RS-485 Connection Method	141
9.3 Modbus/RTU Communication	142
9.3.1 Data Encoding.....	142
9.3.2 Communication Address	142
9.3.3 Communication Baud Rate And Framing	142
9.3.4 Power Up Mode	143
9.3.6 M2DC series Servo Drive Register Addresses and Function List:	143
9.3.7 Command Opcode Description	151
9.3.8 Function Code	153
9.3.9 Modbus/RTU Applications	156
9.4 CANopen Communication.....	162
9.4.1 RJ45 (8p8c) Pin Definitions.....	162
9.4.2 CANopen NODE-ID.....	162
9.4.3 CANopen Communication Baud Rate	162
10 Trouble Shooting	163
10.1 Drive Alarm List	163
Appendix	166
Appendix 1: LED Character Reference.....	166
Appendix 2: Cables and Connectors.....	166

Revision History

Document History	Date	Remarks
v1.0	2016.06.20	
v1.1	2018.04.20	Add M2DC-20D drvie

Disclaimer

The information in this manual was accurate and reliable at the time of its release. MOONS' reserves the right to change the specifications of the product described in this manual without notice at any time.

Trademarks

All marks in this manual are the property of their respective owners

Customer Service

MOONS' is committed to delivering quality customer service and support for all our products. Our goal is to provide our customers with the information and resources required in such a way that they are available without delay, if and when they are needed.

In order to serve you in the most effective way, we recommend that you contact your local sales representative for order status and delivery information, product information and literature, and application and field technical assistance. If you are unable to contact your local sales representative for any reason, please use the most relevant of the contact details below:

For technical support, contact: ama-support@moons.com.cn

or call +86-400-820-9661.

1 Introduction

1.1 About This Manual

This manual describes the M2DC Servo Drive.

It provides the information required for installation, configuration and basic operation of the M2DC series servo drive.

This document is intended for persons who are qualified to transport, assemble, commission, and maintain the equipment described herein.

1.2 Documentation Set for the M2DC Series Servo Drive

This manual is part of a documentation set. The entire set consists of the following:

- M2DC Quick Start Guide: Basic setup and operation of the drive
- M2DC Hardware Manual: Hardware installation, configuration and operation
- M Servo Suite Software User Manual: How to use the M Servo Suite software

1.3 Safety

Only qualified persons may perform the installation procedures. The following explanations are for procedures that must be observed in order to prevent harm to people and damage to property.



The M2DC utilizes hazardous voltages. Be sure the drive is properly grounded.

Before you install the M2DC, review the safety instructions in this manual.

Failure to follow the safety instructions may result in personal injury or equipment damage.

1.4 Safety Symbols

Safety symbols indicate a potential for personal injury or equipment damage if the recommended precautions and safe operating practices are not followed.

The following safety-alert symbols are used on the drive and in the documentation:



Caution



Warning - Dangerous voltage



Protective earth



Caution - Hot surface

1.5 Safety Instructions

Installation

	DO NOT subject the product to water, corrosive or flammable gases, or combustibles.
	DO NOT use the motor in a place subject to excessive vibration or shock.
	Never connect the motor directly to the AC power supply.
	DO NOT use cables soaked in water or oil.
	DO NOT extrude or pull off the cable, or damage the cables as electrical shocks or damage may result
	DO NOT block the heat dissipating holes. Prevent any metal filings from dropping into the drive during installation.
	DO NOT switch the power supply on and off repeatedly.
	DO NOT touch the rotating shaft when the motor is running.
	DO NOT strike the motor when during installation as the motor shaft or encoder may be damaged.
	To prevent accidents, the initial trial run for the servo motor should be conducted under a no-load condition (separate the motor from its couplings and belts).
	Starting system operation without first matching the correct parameters may result in servo drive or motor damage, or damage to the mechanical system.
	DO NOT touch the drive heat sink, motor, or the regeneration resistor during operation as they may be very hot.
	DO NOT hold the motor by the cable during transportation or installation.

Wiring

	DO NOT connect any power supply to the U, V, or W terminals.
	Install the encoder cable in a separate conduit from the motor power cable to avoid signal noise.
	Use multi-stranded twisted-pair wires or multi-core shielded-pair wires for signal and encoder cables.
	A hazardous voltage charge may still remain in the drive even after the power has been removed - Do not touch the terminals when the charge led is still lit.
	Please observe the specified voltage(s).
	Make sure both the drive and the motor connect to a class 3 ground.
	Please ensure the grounding wires are securely connected before power up.

1.6 Guideline for Parts Replacement

1.6.1 Parts Replacement

Use the table below for a reference. Parts replacement cycle varies depending on the actual operating conditions. Defective parts should be replaced or repaired when any error has occurred.

 Prohibited	Disassembling for inspection and repair should be carried out only by authorized dealers or service company.
--	--

Ambient conditions: 30°C (annual average), load factor of 80% or lower, operating time of 20 hours or less per day.

Product	Component	Standard replacement cycle	Notes
Drive	Smoothing condenser	Approx. 6 years	These hours or cycles are for reference only. Occurrence of error, may mean replacement is required before the standard replacement cycle is up.
	Aluminum electrolytic capacitor (on PCB)	Approx. 6 years	
	Rush current preventive relay	Approx. 100,000 uses (depending on operating conditions)	
	Rush current preventive resistor	Approx. 20,000 uses (depending on operating conditions)	
Motor	Oil seal	5,000 hours	

1.6.2 Bearing Life

Motor bearing life depends on several factors including: axial and radial loads, motor speed, temperature, and the bearing ratings. Because the front bearing is positioned closest to the motor shaft, it usually carries a higher radial load and has the shortest life.

A common cause for shaft and bearing failure is high radial loads that are created when a pulley is attached to the motor shaft at a large distance from the motor mounting face, and the belt has high tension. To avoid this condition mount pulleys and gears as close to the face of the motor as possible, and avoid over tightening belts. These curves show bearing life, at various speeds and radial loads. The curves were calculated with the radial load applied at the end of the shaft.

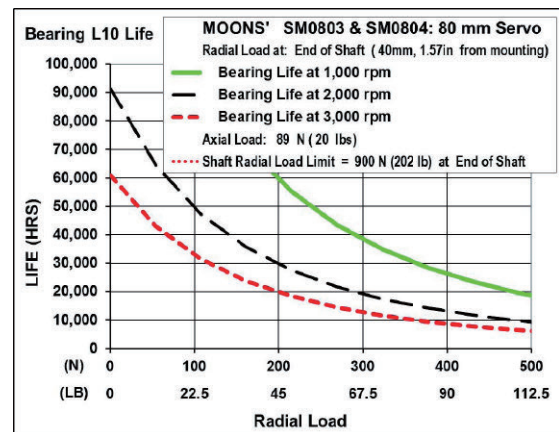
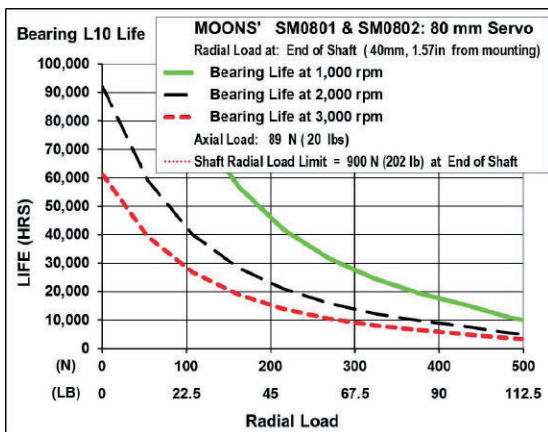
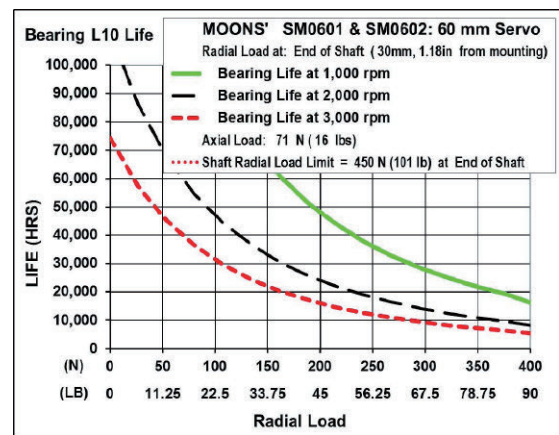
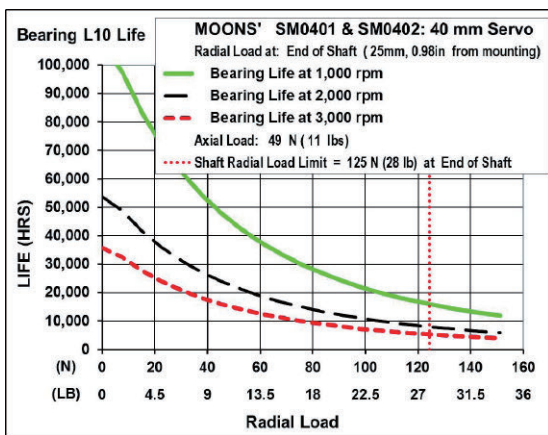
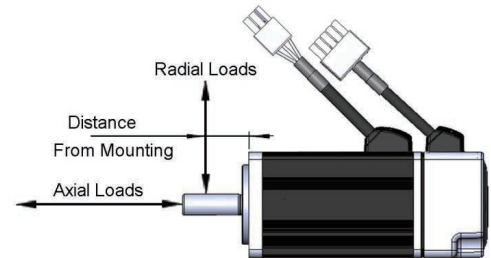

1.7 Standards Compliance

The M2DC Series Servo drive has been designed according to following standard:

- * Electromagnetic compatibility
Standard EN 61800-3

2 Product Description

2.1 System Checklist

A complete and workable M2DC servo system should include the following parts:

1. A matched servo drive and servo motor (refer section 2.4 for recommended combinations)
2. A power cable with a 4-PIN connector to connect P1 (V+, V-, AUX+) to supply power to the drive
3. A motor cable with a 5-PIN connector to supply the servo motor with power from the drive and to connect a regenerative resistor through P2 (U, V, W)
4. An encoder cable with a 26-PIN connector to connect port CN3 for encoder feedback
5. A mini USB cable to connect port CN1 to a PC for communication
6. An I/O cable with a 50-PIN connector to connect port CN2 for I/O
7. Cables with RJ-45 connectors to connect ports CN6 and CN7 for RS-485 or CANopen communication

2.2 Servo Drive Model Introduction

2.2.1 Drive Name Plate Description

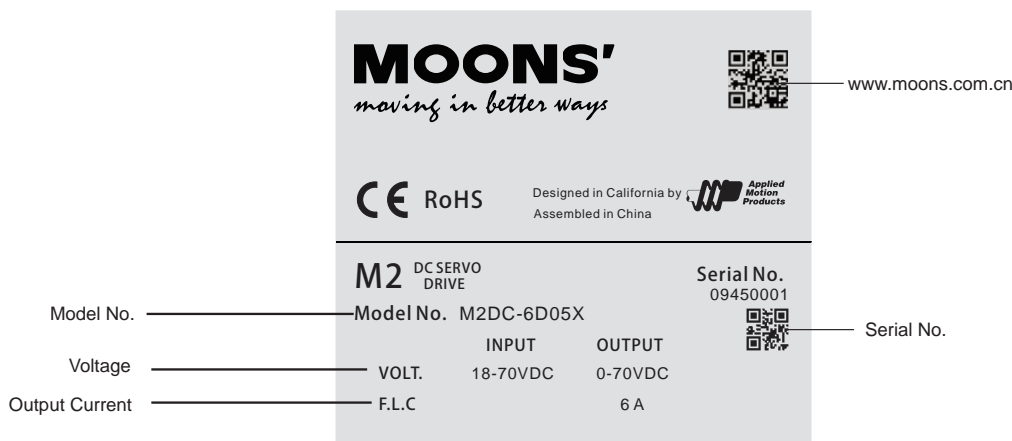

2.2.2 Drive Model Description

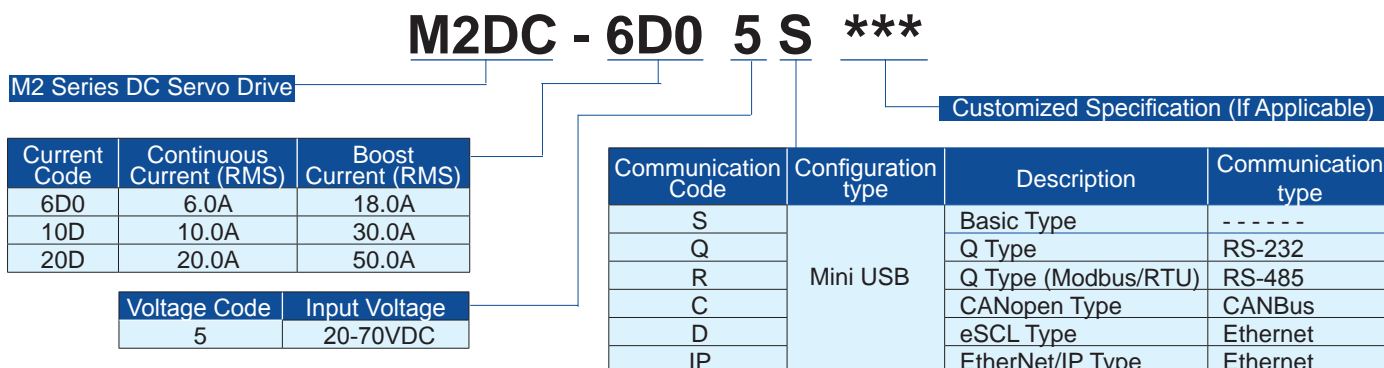

2.2.3 Drive specifications

Input Power	M2DC-6D0 M2DC-10D M2DC-20D	Main Circuit	20 - 70VDC
		Control Circuit	10 - 70VDC
Environment	Temperature		Ambient temperature: 0°C to 50°C (if the ambient temperature of the servo drive is greater than 40°C, please install the drive in a well-ventilated location) Storage temperature: -20°C to 65°C
	Humidity		Both operating and storage: 10 to 85%RH or less
	Altitude		Lower than 1000m
	Vibration		5.88m/s ² or less, 10 to 60Hz (do not use continuously at resonance frequency)
Control method			IGBT PWM Sinusoidal wave drive
Encoder feedback			2500 ppr optical encoder with shared commutation signals
I/O	Control Signal	Input	8 optically isolated multi function inputs, 5-24VDC, 20mA 2 optically isolated multi function high speed inputs, 5-24VDC, 20mA
		Output	6 optically isolated multi function outputs, 5-24VDC, 20mA
	Analog signal	Input	2 inputs (12Bit A/D: 2 input)
		Pulse signal	Input
		Output	3 line driver outputs, 1 open collector output
Communication	Mini USB		Connection with PC or 1 : 1 communication to a host.
	RS-232		RS-232 communication
	RS-485		RS-485 communication & Modbus/RTU
	CANbus		CANopen communication
	Ethernet		EtherNET/IP or eSCL
Front panel			4 keys (MODE, UP, DOWN, SET), LED (5-digit)
Regeneration Resistor			Built-in regenerative resistor (NOT available in M2DC-20D type)
Dynamic Brake			Built-in
Control modes			(1) Position mode (2) Analog velocity mode (3) Analog position mode (4) Position mode (5) Velocity change mode (6) Command torque mode (7) Command velocity mode (8) Position tables
Control inputs			(1) Servo-ON input (2) Alarm clear input (3) CW/CCW Limit (4) Pulse & Direction or CW/CCW input (5) Gain Switch (6) Control mode Switch (7) Pulse Inhibition (8) Gear switch (9) Velocity Change mode (10) Analog input (11) General input
Control outputs			(1) Alarm output (2) Servo-Ready output (3) External brake release (4) Speed reached output (5) Torque reached output (6) Position reached output (7) TachOut (8) Servo-on status output (9) General output
Certification			RoHS
Drive Mass	M2DC-6D0	0.59kg	
	M2DC-10D	0.59kg	
	M2DC-20D	0.61kg	

2.2.4 Drive Dimensions (Unit: mm)

□ M2DC-6D0/10D

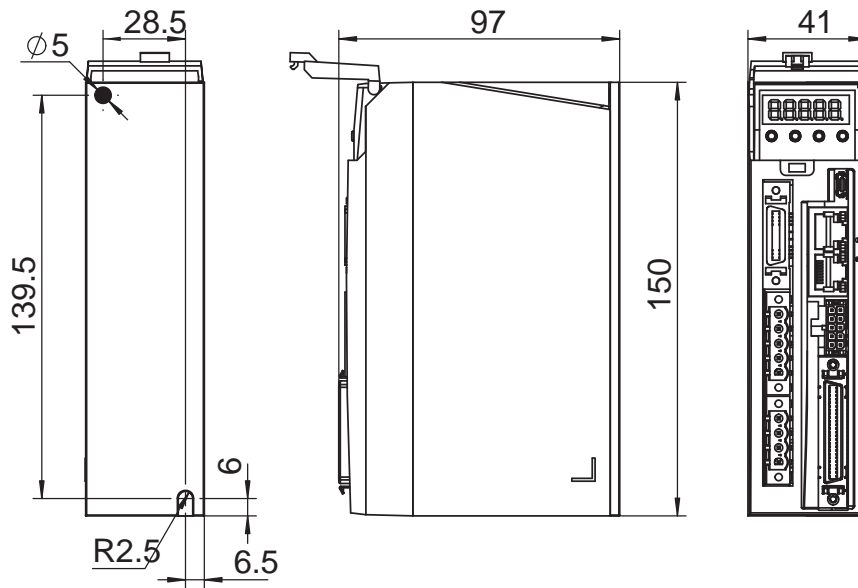

□ M2DC-20D

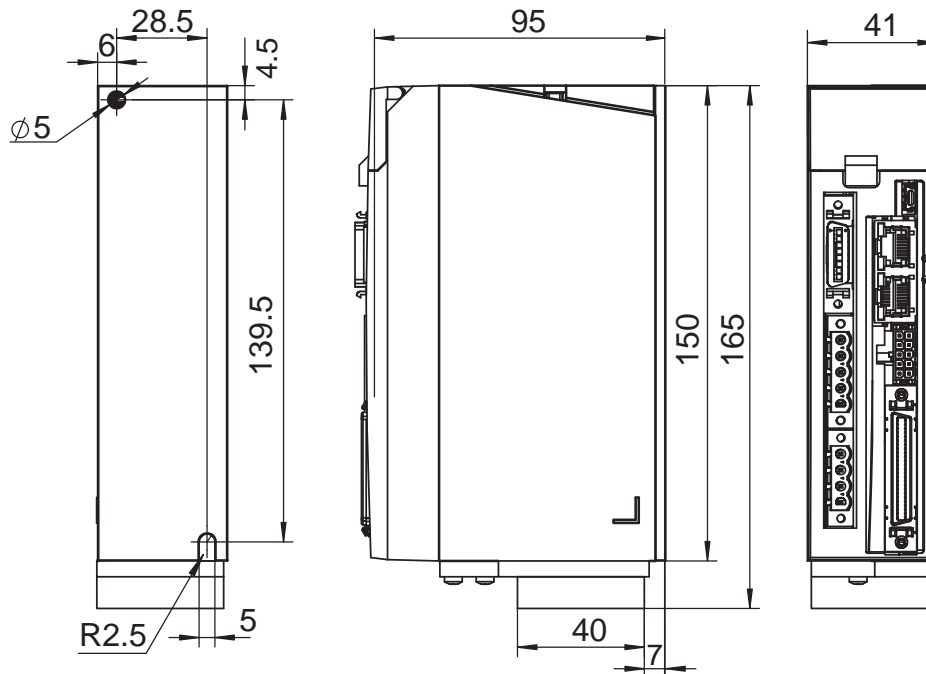

2.3 Servo Motor Model Introduction

2.3.1 Motor Name Plate Description

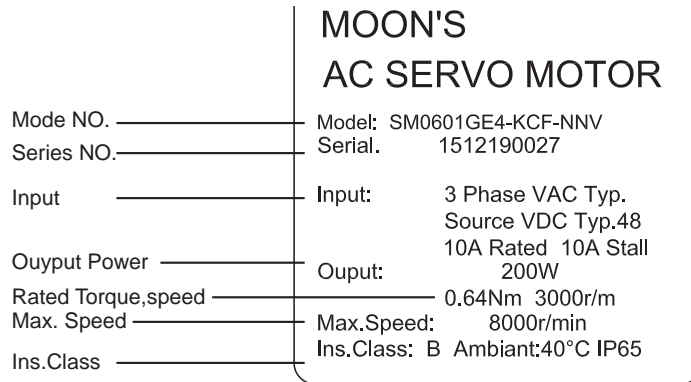

2.3.2 Motor Model Description

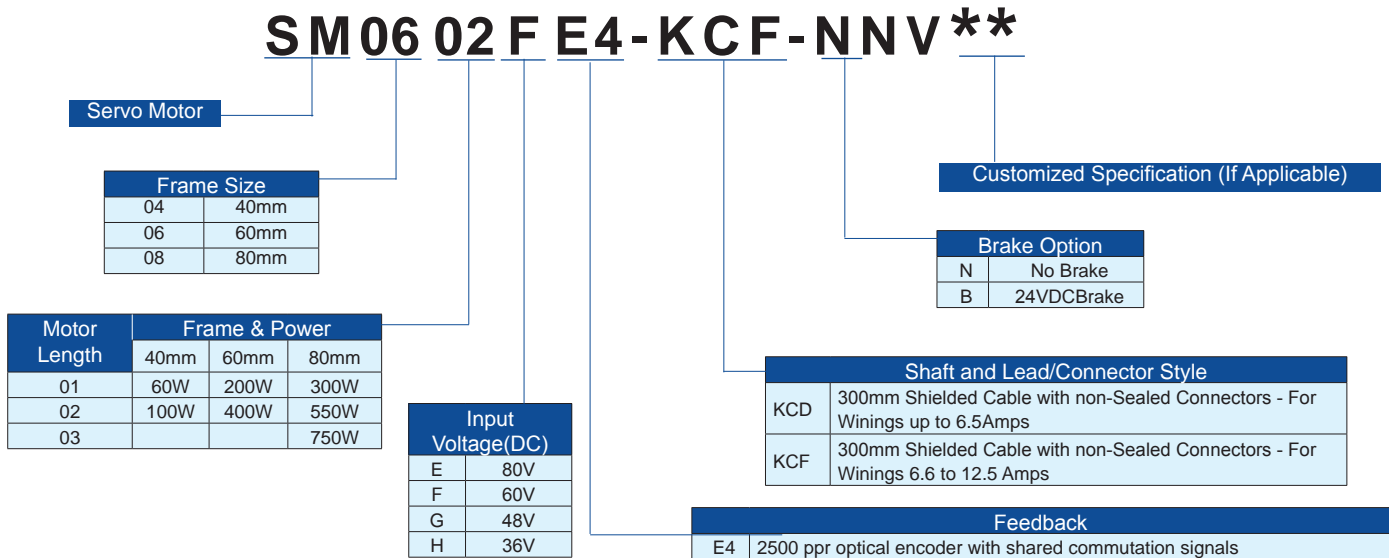

2.3.3 Motor Specifications and Dimensions

2.3.3.1 40mm Specifications and Dimensions

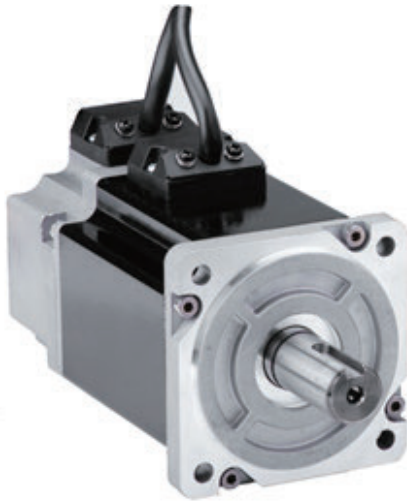

UL File	E465363
Insulation Class	Class B (130)
IP rating	IP65 (except shaft through hole and cable end connector)
Installation location	Indoors, away from direct sunlight, corrosive gas, flammable gas
Ambient temperature	Operating 0 to 40°C, Storage -20 to 65°C
Ambient humidity	85%RH or lower (free from condensation)
Altitude (maximum)	Operating 1,000m
Vibration Resistance	49 m/s ²
Rotor Poles	8

40mm Series

Series		SM0401 - 60 Watt	SM0402 - 100 Watt
Base Model Number (with 2500 PPR incremental encoder non-sealed plastic connectors, no brake)		SM0401HE4-KCD-*NV	SM0402FE4-KCD-*NV
DC bus(VDC)		36	60
Rated Output Power	watts	60	100
Rated Speed	rpm	3000	3000
Max. Mechanical Speed	rpm	6000	6000
Rated Torque	Nm	0.19	0.32
Continuous Stall Torque	Nm	0.2	0.34
Peak Torque	Nm	0.48	0.93
Rated Current	A (rms)	5.7	5.2
Continuous Stall Current	A (rms)	6	5.6
Peak Current	A (rms)	14.3	15.6
Voltage Constant ±5%	V (rms) / K rpm	2.1	3.8
Torque Constant ±5%	Nm / A (rms)	0.035	0.061
Winding Resistance (Line-Line)	Ohm ±10% @25°C	0.36	0.48
Winding Inductance (Line-Line)	mH (typ.)	0.39	0.58
Inertia (with encoder)	kg m ²	0.0232 X 10 ⁻⁴	0.0428 X 10 ⁻⁴
Inertia - With Brake Option	kg m ²	0.0298 X 10 ⁻⁴	0.0494 X 10 ⁻⁴
Heat Sink Size	mm	120 x 120 x 5 Aluminum	120 x 120 x 5 Aluminum
Shaft Load - Axial	(max.)	50 N / 11 lb	50 N / 11 lb
Shaft Load - Radial (End of Shaft)	(max.)	50 N / 11 lb	60 N / 13.5 lb
Weight (with std. encoder)		0.4 kg / 0.9 lb	0.55 kg / 1.2 lb
Weight - With Brake Option		0.65 kg / 1.4 lb	0.8 kg / 1.8 lb

40mm Dimensions

Motor Dimensions – No Brake: mm

Motor Dimensions – Brake: mm

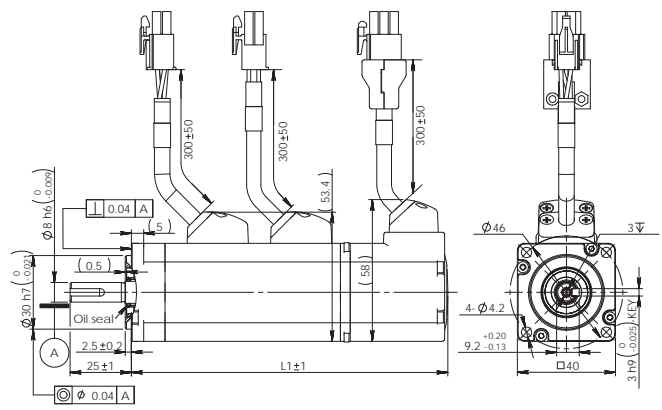
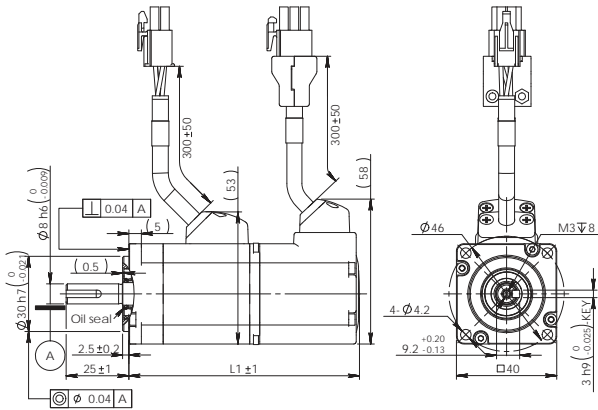

Without Brake	L1
SM0401HE4-KCD-NNV	92
SM0402FE4-KCD-NNV	109

With Brake	L1
SM0401HE4-KCD-BNV	129
SM0402FE4-KCD-BNV	147

40mm Torque curves

DC Bus--24VDC
SM0401HE4(60 Watts) -5.7 Amps

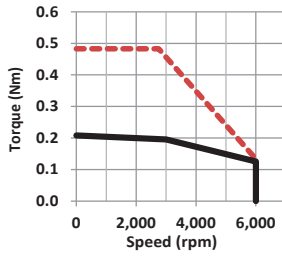

DC Bus--36VDC
SM0401HE4(60 Watts) - 5.7 Amps

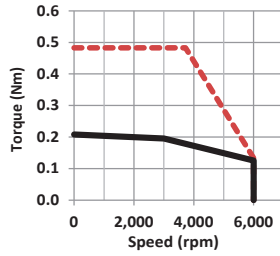

DC Bus--48VDC
SM0401HE4(60 Watts) - 5.7 Amp

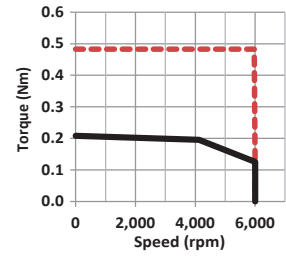

DC Bus--24VDC
SM0402FE4(100 Watts) -5.2Amps

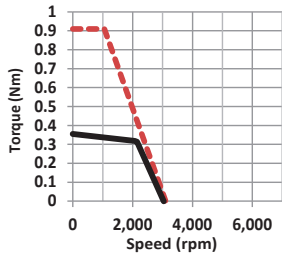

DC Bus--48VDC
SM0402FE4(100 Watts) -5.2Amps

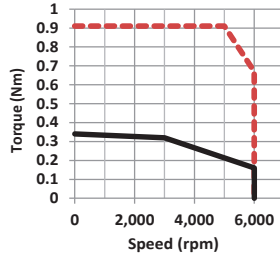

DC Bus--60VDC
SM0402FE4(100 Watts) -5.2Amps

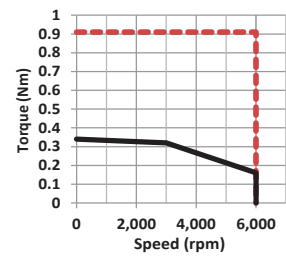

----- Max. Intermittent Torque
————— Max. Continuous Torque

2.3.3.2 60mm Specifications and Dimensions



UL File	E465363
Insulation Class	Class B (130)
IP rating	IP65 (except shaft through hole and cable end connector)
Installation location	Indoors, away from direct sunlight, corrosive gas, flammable gas
Ambient temperature	Operating 0 to 40°C, Storage -20 to 65°C
Ambient humidity	85%RH or lower (free from condensation)
Altitude (maximum)	Operating 1,000m
Vibration Resistance	49 m/s ²
Rotor Poles	8

60mm Series

Series		SM0601 - 200 Watt		SM0602 - 400 Watt	
Base Model Number (with 2500 PPR incremental encoder non-sealed plastic connectors, no brake)		SM0601 GE4-KCF-*NV	SM0601 EE4-KCF-*NV	SM0602 FE4-KCD-*NV	SM0602 GE4-KCD-*NV
DC Bus(VDC)		48	80	60	48
Rated Output Power	watts	200	200	400	400
Rated Speed	rpm	3000	3000	3000	3000
Max. Mechanical Speed	rpm	6000	6000	6000	6000
Rated Torque	Nm	0.64	0.64	1.26	1.27
Continuous Stall Torque	Nm	0.68	0.68	1.27	1.27
Peak Torque	Nm	1.9	1.9	3.4	3.4
Rated Current	A (rms)	10	5.2	10	12
Continuous Stall Current	A (rms)	10	5.5	10	12
Peak Current	A (rms)	30	15.6	30	30
Voltage Constant ±5%	V (rms) / K rpm	4.1	7.9	7.4	6.3
Torque Constant ±5%	Nm / A (rms)	0.065	0.125	0.123	0.103
Winding Resistance (Line-Line)	Ohm ±10% @25°C	0.192	0.67	0.25	0.214
Winding Inductance (Line-Line)	mH	0.56	2	0.84	0.6
Inertia (with encoder)	kg m ²	0.165 X 10 ⁻⁴	0.165 X 10 ⁻⁴	0.272 X 10 ⁻⁴	0.272 X 10 ⁻⁴
Inertia - With Brake Option	kg m ²	0.22 X 10 ⁻⁴	0.22 X 10 ⁻⁴	0.326 X 10 ⁻⁴	0.326 X 10 ⁻⁴
Heat Sink Size	mm	180 x 180 x 5 Aluminum	180 x 180 x 5 Aluminum	180 x 180 x 5 Aluminum	180 x 180 x 5 Aluminum
Shaft Load - Axial	(max.)	70 N / 15 lb	70 N / 15 lb	70 N / 15 lb	70 N / 15 lb
Shaft Load - Radial (End of Shaft)	(max.)	200 N / 45 lb	200 N / 45 lb	240 N / 54 lb	240 N / 54 lb
Weight (with std. encoder)		1.1 kg / 2.3 lb	1.1 kg / 2.3 lb	1.4 kg / 3.1 lb	1.4 kg / 3.1 lb
Weight - With Brake Option		1.6 kg / 3.5 lb	1.6 kg / 3.5 lb	1.9 kg / 4.2 lb	1.9 kg / 4.2 lb

60mm Dimensions

Motor Dimensions – No Brake: mm

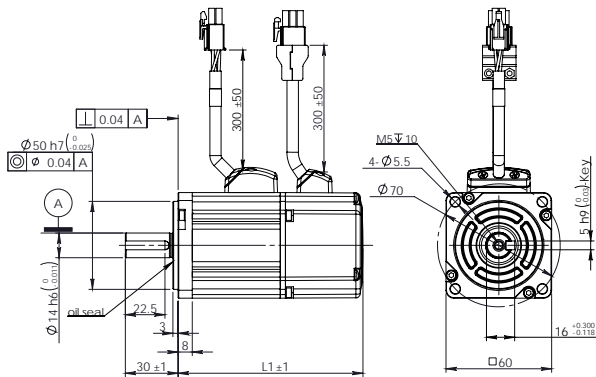

Without Brake	L1
SM0601GE4-KCF-NNV	105
SM0601EE4-KCD-NNV	
SM0602FE4-KCF-NNV	125
SM0602GE4-KCF-NNV	125

Motor Dimensions – Brake: mm

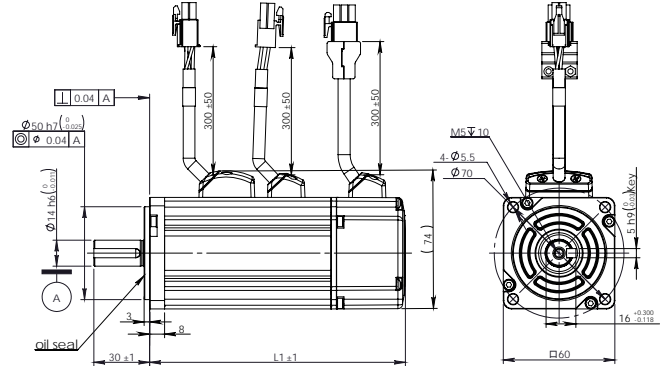

With Brake	L1
SM0601GE4-KCF-BNV	145
SM0601EE4-KCD-BNV	
SM0602FE4-KCF-BNV	165
SM0602GE4-KCF-BNV	165

60mm Torque curves

SM0601GE4(200 Watts) -10Amps
DC Bus--24VDC

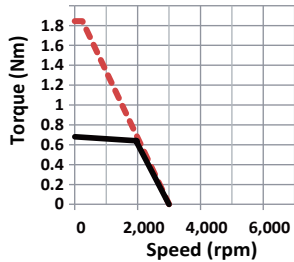

SM0601GE4(200 Watts) -10Amps
DC Bus--48VDC

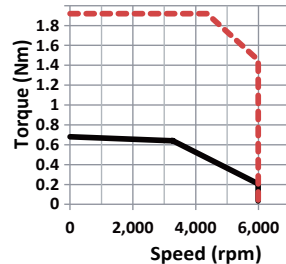

SM0601GE4(200 Watts) -10Amps
DC Bus--60VDC

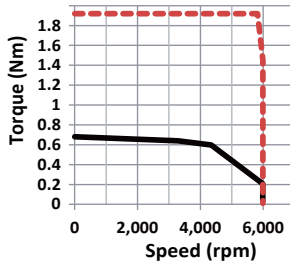

SM0601EE4(200 Watts) -5.2Amps
DC Bus--48VDC

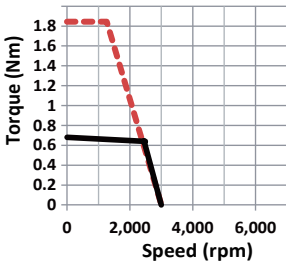

SM0601EE4(200 Watts) -5.2Amps
DC Bus--60VDC

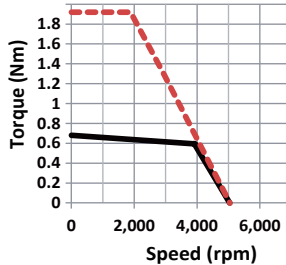

SM0602GE4(400 Watts) -12Amps
DC Bus--48VDC

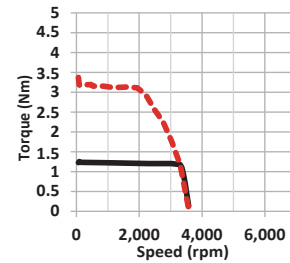

SM0602FE4(400 Watts) -10Amps
DC Bus--24VDC

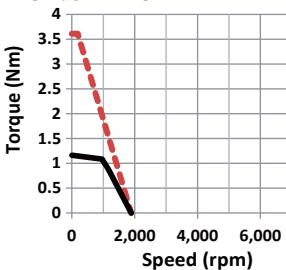

SM0602FE4(400 Watts) -10Amps
DC Bus--48VDC

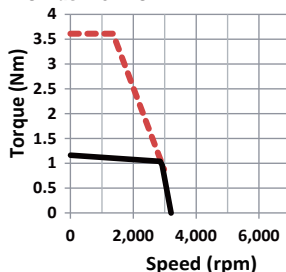

SM0602FE4(400 Watts) -10Amps
DC Bus--60VDC

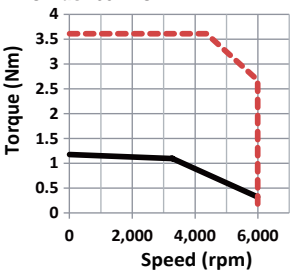

--- Max. Intermittent Torque
— Max. Continuous Torque

2.3.3.3 80mm Specifications and Dimensions



UL File	E465363
Insulation Class	Class B (130)
IP rating	IP65 (except shaft through hole and cable end connector)
Installation location	Indoors, away from direct sunlight, corrosive gas, flammable gas
Ambient temperature	Operating 0 to 40°C, Storage -20 to 65°C
Ambient humidity	85%RH or lower (free from condensation)
Altitude (maximum)	Operating 1,000m
Vibration Resistance	49 m/s ²
Rotor Poles	8

80mm Series

Series		SM0801 - 300 Watt	SM0802 - 300 Watt
Base Model Number (with 2500 PPR incremental encoder non-sealed plastic connectors, no brake)		SM0801 GE4-KCF-*NV	SM0802 EE4-KCF-*NV
DC Bus(VDC)		48	80
Rated Output Power	watts	300	550
Rated Speed	rpm	3000	3000
Max. Mechanical Speed	rpm	6000	5500
Rated Torque	Nm	0.95	1.8
Continuous Stall Torque	Nm	1	1.9
Peak Torque	Nm	2.3	4.6
Rated Current	A (rms)	10	10
Continuous Stall Current	A (rms)	10.6	10.7
Peak Current	A (rms)	25	28
Voltage Constant ±5%	V (rms) / K rpm	6.2	11.2
Torque Constant ±5%	Nm / A (rms)	0.096	0.176
Winding Resistance (Line-Line)	Ohm ±10% @25°C	0.188	0.22
Winding Inductance (Line-Line)	mH	0.85	1.25
Inertia (with encoder)	kg m ²	0.45 X 10 ⁻⁴	0.63 X 10 ⁻⁴
Inertia - With Brake Option	kg m ²	0.53 X 10 ⁻⁴	0.71 X 10 ⁻⁴
Heat Sink Size	mm	240 x 240 x 6 Aluminum	240 x 240 x 6 Aluminum
Shaft Load - Axial	(max.)	90 N / 20 lb	90 N / 20 lb
Shaft Load - Radial (End of Shaft)	(max.)	270 N / 60 lb	270 N / 60 lb
Weight (with std. encoder)		1.7 kg / 5.8 lb	2.2 kg / 5.8 lb
Weight - With Brake Option		2.5 kg / 7.6 lb	3.0 kg / 7.6 lb

80mm Dimensions

Motor Dimensions – No Brake: mm

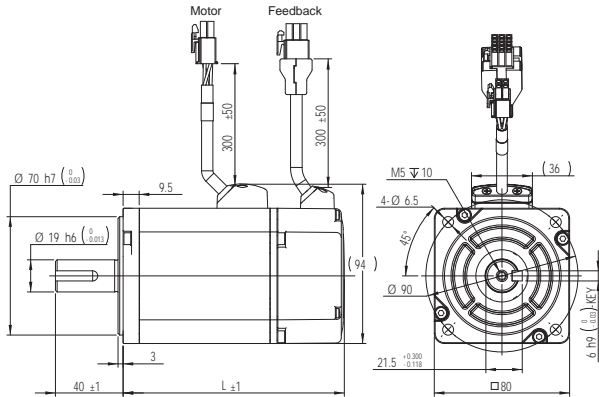

Without Brake	L1
SM0801GE4-KCF-NNV	101
SM0802EE4-KCF-NNV	116

Motor Dimensions – Brake: mm

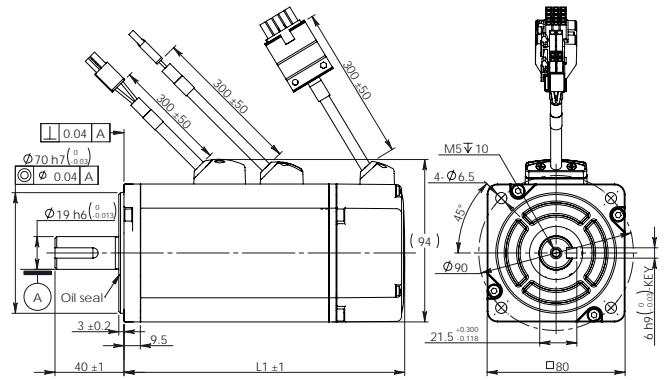

With Brake	L1
SM0801GE4-KCF-BNV	148
SM0802EE4-KCF-BNV	163

80mm Torque Curve

SM0801GE4(300 Watts) -10Amps
DC Bus--24VDC

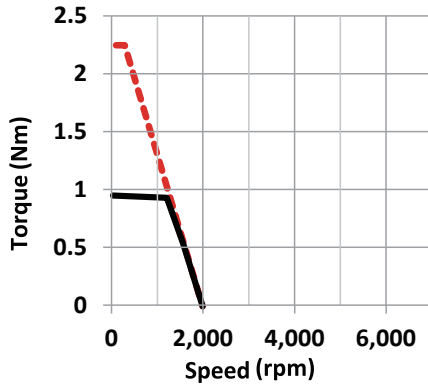

SM0801GE4(300 Watts) -10Amps
DC Bus--48VDC

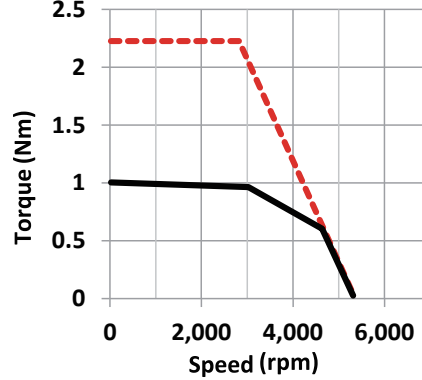

SM0802 (550 Watts) - 绕组 E
48 VDC - 10 Amps

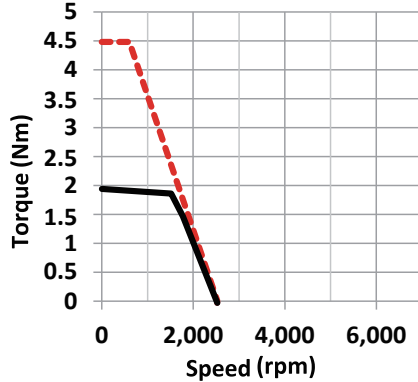

SM0802 (550 Watts) - 绕组 E
60 VDC - 10 Amps

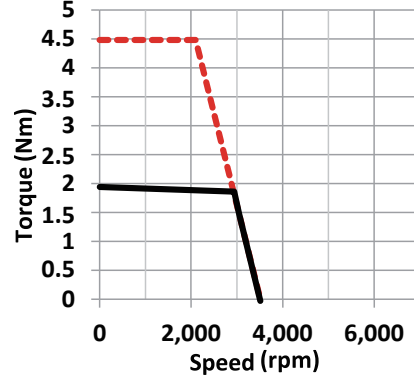

----- Max. Intermittent Torque
 _____ Max. Continuous Torque

M2DC Servo Motor Specifications and Dimensions—Frame 80mm

Model		SM0803GE4-KCF-NNV	
Recommended Drive Input Voltage (DC-Bus)		48	
Rated Output Power	watts	750	
Rated Speed	rpm	3000	
Max. Speed	rpm	3600	
Rated Torque	Nm	2.4	
Peak Torque	Nm	6	
Rated Current	A (rms)	22.5	
Peak Current	A (rms)	56.5	
Voltage Constant±5%	V (rms) / K rpm	7.8	
Torque Constant±5%	Nm / A (rms)	0.11	
Winding Resistance(Line-Line)	Ohm @25°C	0.06	
Winding Inductance(Line-Line)	mH (typ.)	0.43	
Rotor Inertia	Kg·m ²	0.89 × 10 ⁻⁴	
Rotor Inertia - With Brake	Kg·m ²	0.97 × 10 ⁻⁴	
Shaft Load - Axial	N (max.)	90	
Shaft Load - Radial (End of Shaft)	N (max.)	270	
Weight	kg	2.6	
Weight - With Brake	kg	3.4	

Dimensions (Unit:mm)

1) Without Brake

2) With Brake

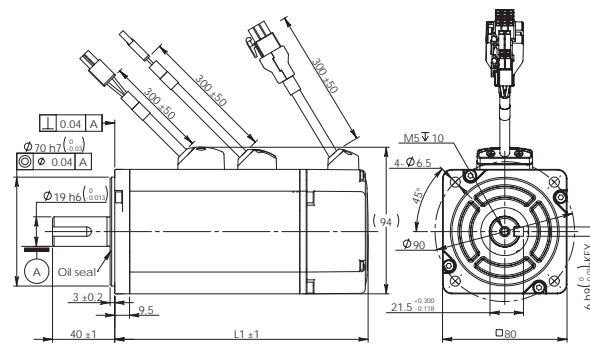
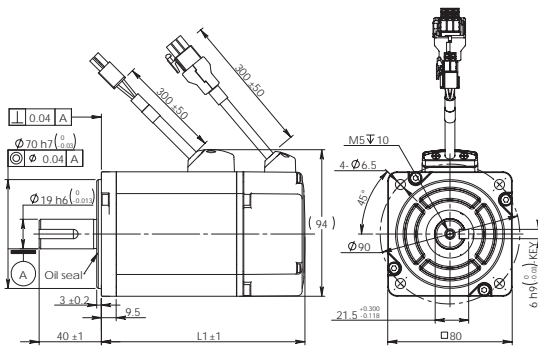

Without Brake	L1
SM0803GE4-KCF-NNV	130.8

With Brake	L1
SM0803GE4-KCF-BNV	178



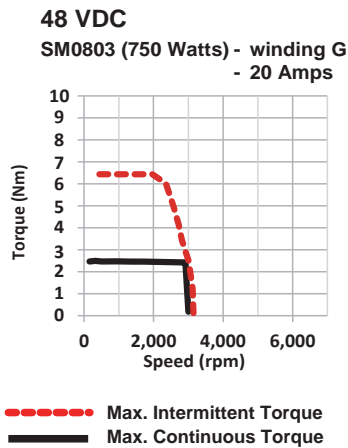

Torque Curves

Note: The torque and maximum speed depend on the DC bus voltage. Please choose proper supply voltage.



2.4 Servo Drive and Servo Motor Combinations

Servo Drive			
			
Basic Type	M2DC-6D05S	M2DC-10D5S	M2DC-20D5S
Q Program Type (RS-232 Communication)	M2DC-6D05Q	M2DC-10D5Q	M2DC-20D5Q
Q Program Type (RS-485 Communication)	M2DC-6D05R	M2DC-10D5R	M2DC-20D5R
CANopen	M2DC-6D05C	M2DC-10D5C	M2DC-20D5C
eSCL	M2DC-6D05D	M2DC-10D5D	M2DC-20D5D
EtherNet/IP*	M2DC-6D05IP	M2DC-10D5IP	M2DC-20D5IP

Matching Motor				
				
	40 Frame, 60W, 100W	60 Frame, 200W, 400W	80 Frame, 300W, 550W	80 Frame, 750W
Without Brake	SM0401HE4-KCD-NNV SM0402FE4-KCD-NNV	SM0601GE4-KCF-NNV SM0602FE4-KCF-NNV SM0602GE4-KCF-NNV	SM0801GE4-KCF-NNV SM0802EE4-KCF-NNV	SM0803GE4-KCF-NNV
With Brake	SM0401HE4-KCD-BNV SM0402FE4-KCD-BNV	SM0601GE4-KCF-BNV SM0602FE4-KCF-BNV SM0602GE4-KCF-BNV	SM0801GE4-KCF-BNV SM0802EE4-KCF-BNV	SM0803GE4-KCF-BNV

Gearhead Motor				
Without Brake	SM0401HE4-KCD-NNV-PG**A SM0402FE4-KCD-NNV-PG**A	SM0601GE4-KCF-NNV-PG**A SM0602FE4-KCF-NNV-PG**A	SM0801GE4-KCF-NNV-PG**A SM0802EE4-KCF-NNV-PG**A	
With Brake	SM0401HE4-KCD-BNV-PG**A SM0402FE4-KCD-BNV-PG**A	SM0601GE4-KCF-BNV-PG**A SM0602FE4-KCF-BNV-PG**A	SM0801GE4-KCF-BNV-PG**A SM0802EE4-KCF-BNV-PG**A	

* For the latest details, Please contact our company.

** Standard gear ratios are 5:1; 10:1 and 20:1.

Accessories			
IO Connector			M2-50P
USB mini-B Configuration Cable			2620-150
Standard*	Motor power Cable	1630-X00	1627-X00
	Encoder Cable		2627-X00
	Brake Cable***		1602-X00
Flexible**	Motor power Cable	1631-X00	1628-X00
	Encoder Cable		2621-X00
	Brake Cable***		1602-X00-C05

* Standard: Can not be used in a drag chain.

** Bending test: Min. bend radius: 100mm, Travel distance: 60mm, Lifetime: 5,000,000c.

3 Installation

3.1 Storage Conditions

- Store properly packaged in a clean and dry environment, away from direct sunlight
- Store in an ambient temperature range of -20°C to +65°C
- Store where the relative humidity range is 10% to 85% with non-condensing
- DO NOT store in a place exposed to corrosive gases

3.2 Installation Conditions

- Temperature range of 0°C to 50°C. If the ambient temperature of the servo drive is greater than 40°C, please install it in a well-ventilated location.
- The ambient temperature of the servo drive for long-term reliability should be less than 45°C.
- The servo drive and motor will generate heat; if they are installed in a control panel, please ensure sufficient space around the units for heat dissipation.
- Operate where the relative humidity range is 10% to 85% and non-condensing
- Install where the vibration is lower than 5.88m/s², 10Hz-60Hz (DO NOT use the drive for extended periods of time at the resonance point.)
- DO NOT install the servo drive and motor in a location subjected to corrosive or flammable gases, or combustibles.
- Install the servo drive and motor in an indoor electric control cabinet.
- DO NOT install the servo drive and motor in a location subject to airborne dust.

3.3 Installation Space

Incorrect installation may result in a drive malfunction or premature failure of the drive and/or motor. Please follow the guidelines in this manual when installing the servo drive and motor.

The M2DC servo drive should be installed perpendicular to the wall or in a control panel.

In order to ensure the drive is well ventilated, make sure ventilation holes are not obstructed, there is sufficient free space around the servo drive, and a cooling fan is mounted in the control panel.

Ensure the grounding wires are securely connected

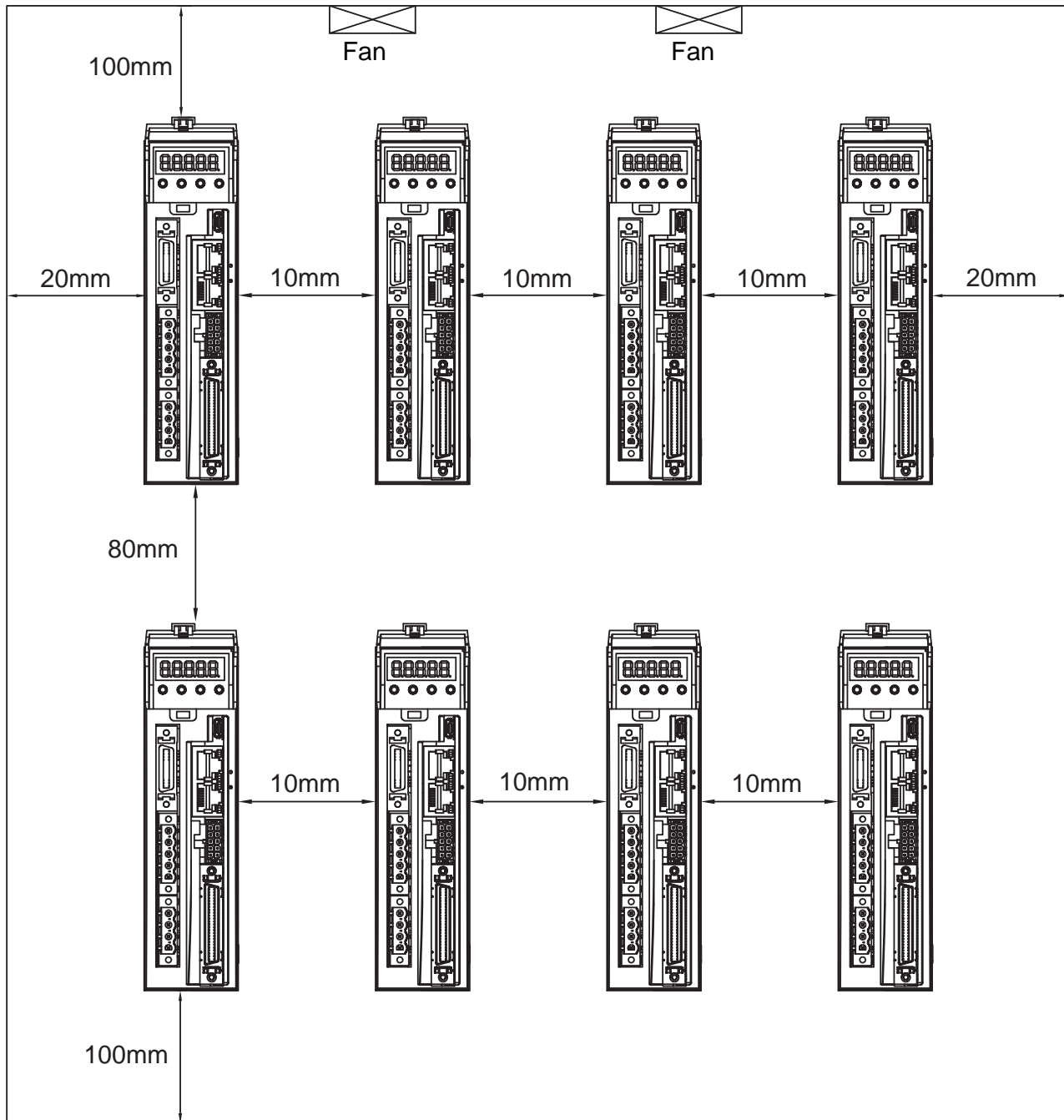

3.4 Motor Installation

- DO NOT strike the motor when installing it as the motor shaft or encoder may be damaged.

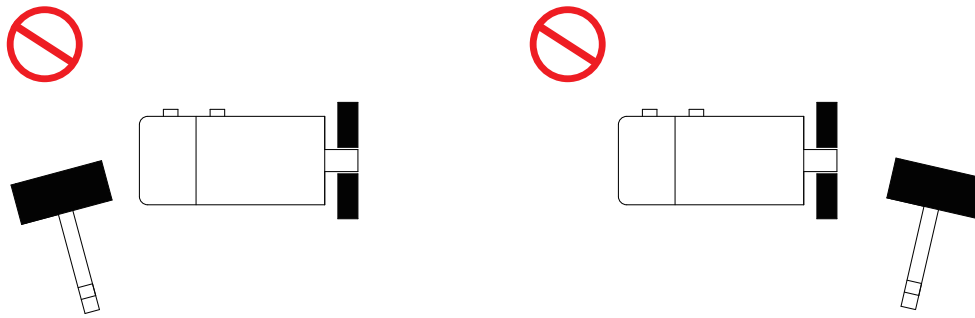

- DO NOT use cables that have been soaked with water or oil.
- Avoid a stress application to the cable outlet and connecting portion by bending.
- Use flexible cables when using a cable carrier, and make sure the minimum cable bending diameter is 200mm.
- The shaft through hole and cable end connector are not IP65 designed. Be careful to prevent any liquid or oil from getting into the motor at these areas.

4.1.2 Servo Drive Connectors and Terminals

Terminal Identification	Description	Details		
P1	V+, V-	Used to connect DC main circuit power		
	AUX	Used to connect an auxiliary circuit power		
	⊕	Ground		
P2	U, V, W	Used to connect servo motor		
		Terminal Symbol	Wire color	Description
		U	Red	Connects to servo motor
		V	Yellow	
	W	Blue		
⊕	Ground			
P3	External regeneration resistor port	Connect to external regeneration absorbing resistor		
CN1	Communication Port	User to connect PC		
CN2	I/O Connector	Used to connect external controllers		
CN3	Encoder Feedback Connector	Used to connect servo motor encoder		
CN4	Reserved			
CN5	STO Connector	Used to connect STO (Safe Torque Off)		
CN6	RS-485/CANopen Port	RJ45 connector, Daisy Chain, Used for RS-485/CANopen/ Ethernet *RS-232 Communication Port (-Q Type Only)		
	Ethernet Port			
CN7	*RS-232 Communication Port	RJ45 connector, Daisy Chain, Used for RS-485/CANopen / Ethernet Communication		
	RS-485/CANopen Port			
	Ethernet Port			
	Communication Port			

4.1.3 Connections and Wiring Notes

- Ensure the grounding wires are securely connected. Wire with a cross section of more than 2.0mm² is recommended.
- Grounding method must be single point grounding.
- Ensure V+ and V- are correctly wired, and voltage supplies are within the specified range.
- Auxiliary power V+ connects to drive AUX connector, auxiliary power V- connects to drive V-.
- Ensure U/V/W is wired following the order of RED/YELLOW/BLUE.
- An isolation transformer or EMI filter is recommended on drive's power supply to ensure the drive's safety and improve its anti-interference level.
- Set up emergency stop circuitry to switch off the power supply when a fault occurs.
- DO NOT touch the drive or motor's connector terminals for at least 5 minutes after the drive and motor have been powered off. There are electrical charge components in the circuitry which discharge slowly.
- Install the encoder cables in a separate conduit from the motor power cables to avoid signal noise. Separate the conduits by at least 30cm (11.8 inches).
- Use multi-stranded twisted-pair wires or multi-core shielded-pair wires for the encoder feedback cables.
- The maximum length of the signal input/output cable should be no more 5 meters, and the encoder (PG) feedback cable no more than 15 meters.

4.1.4 Wiring Methods for P1 Power Supply Connector

Power for the M2DC servo drives comes from 2 different sources

	Pin	Function	Input Power
Main power supply	V+, V-	Drive's main power input	20 - 70VDC
Control circuitry power/ auxiliary power	AUX, V-	When the main power supply is off, the AUX power will keep the logic circuitry alive, allowing the drive to remember its current state data (motor position, etc.) The motor is then able to resume operation without running a homing routine while the main power is switch-on again.	10 - 70VDC

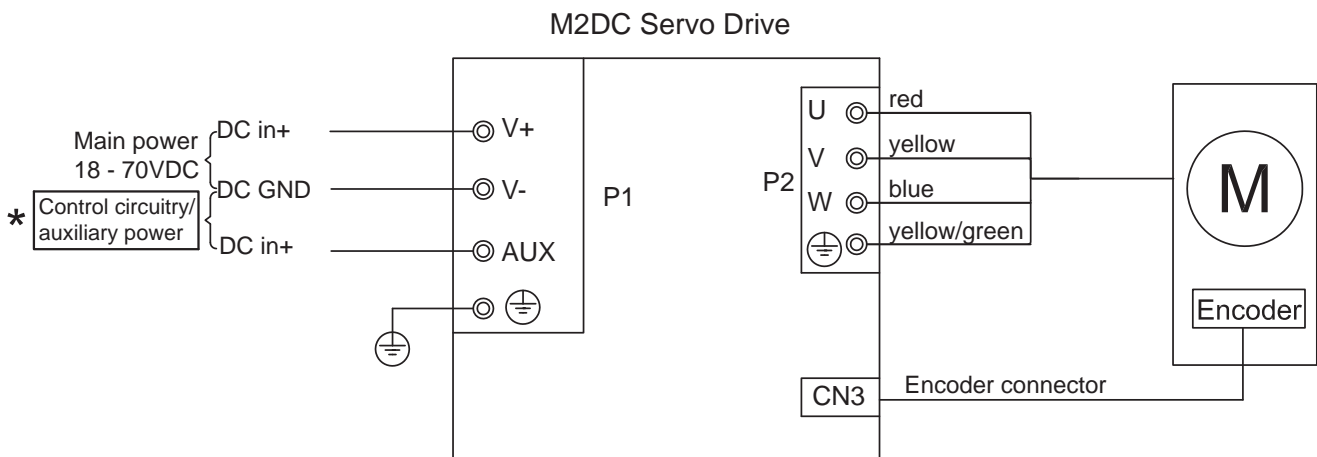

***Note:** For optimized motion performance, make sure the main power input voltage is higher than the motor winding voltage by at least 2VDC.

4.2 Wiring to the P2 Connector

4.2.1 Motor Power Cable Configuration

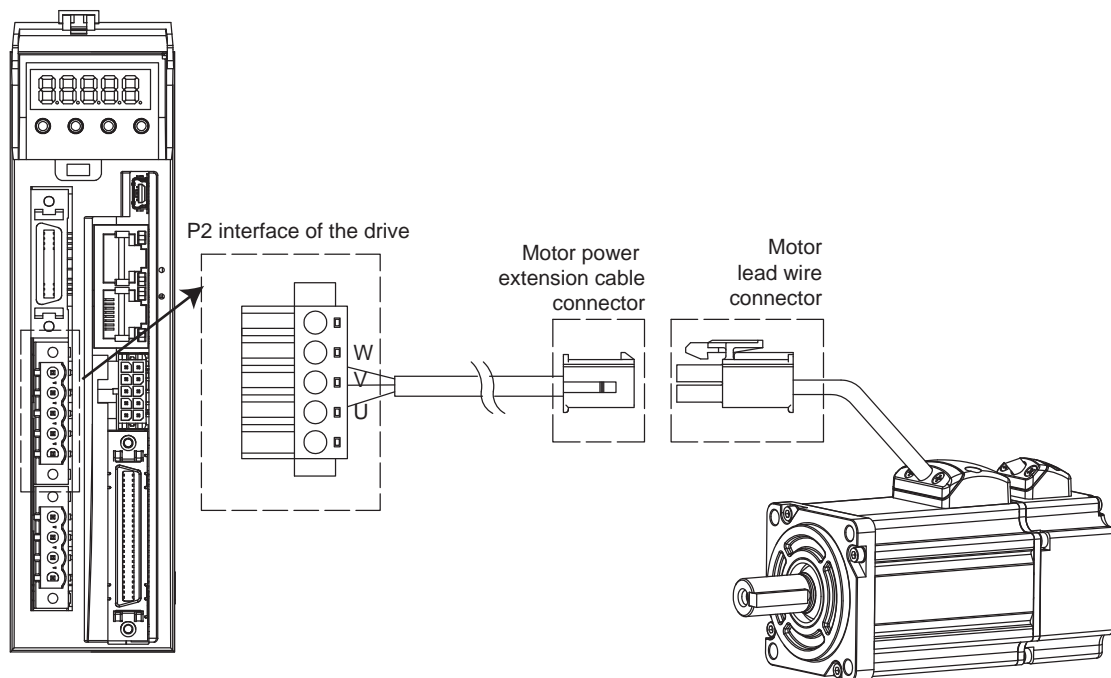

PIN	1	2	3	4
Signal	PE	U	V	W
Colour	Yellow/Green	Red	Yellow	Blue

4.2.2 Motor Power Cable Connector(-CD Winding ,6Amps)

4.2.2.1 PIN Assignment

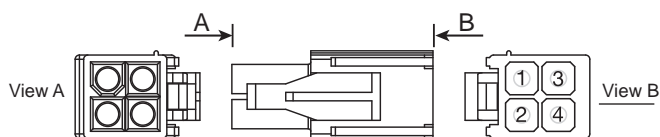

Pin	1	2	3	4
Signal	U	V	W	PE
Color	Red	Yellow	Blue	Yellow/Green

4.2.2.2 Motor Connector Specifications

Type	Motor side (plug)	Extension cable (housing)
Housing	AMP 172167-1	AMP 172159-1
Terminal	AMP 170360-1	AMP 170362-1

4.2.2.3 Motor Extension Cable Wiring Diagram

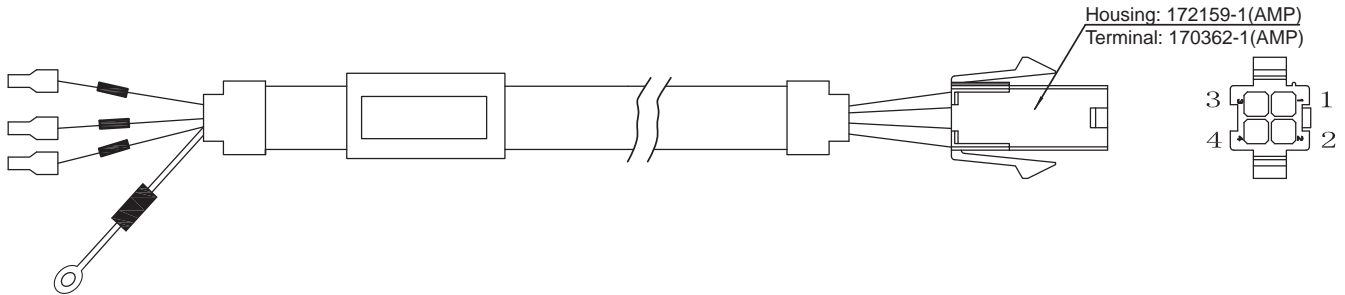

Drive side (P2)	Signal	Color	Housing for the motor
5452571(Phoenix)			AMP 172159-1
U	U	Red	1
V	V	Yellow	2
W	W	Blue	3
⊕	PE	Yellow/Green	4

Ensure U/V/W is wired in the order of RED/YELLOW/BLUE.

4.2.3 Motor Power Cable Connector(-CF Winding,10 and 20Amps)

4.2.3.1 PIN Assignment

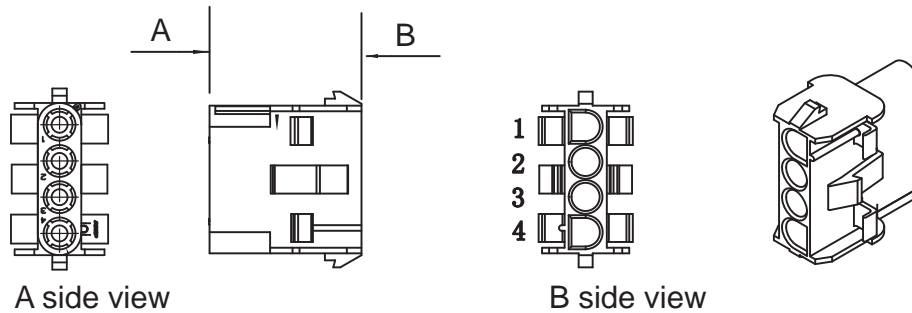

Pin	1	2	3	4
Signal	U	V	W	PE
Color	Red	Yellow	Blue	Yellow/Green

Motor Connector Specifications(200/300/400/550W)

Type	Motor side (plug)	Extension cable (housing)
Housing	AMP 350779-1	AMP 350780-1
Terminal	AMP 350218-1	AMP 350536-1

Motor Connector Specifications(750W)

Type	Motor side (plug)	Extension cable (housing)
Housing	AMP 350779-1	AMP 350780-1
Terminal	AMP 350922-6	AMP 350923-6

4.2.3.2 Motor Extension Cable Wiring Diagram

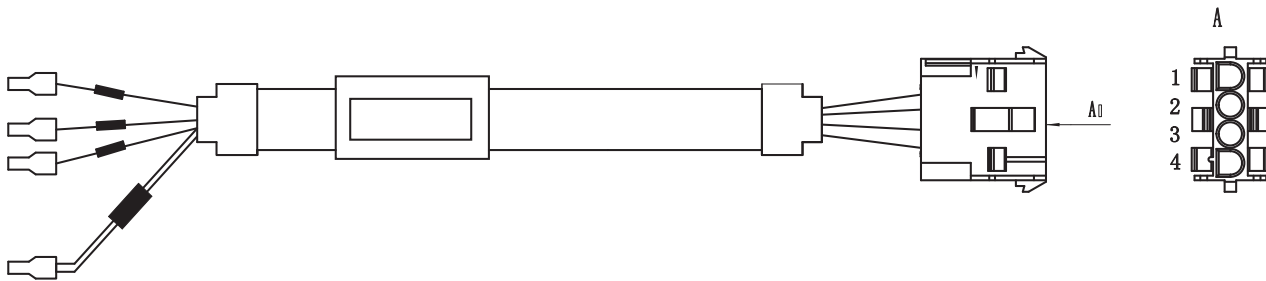

Drive side (P2)	Signal	Color	Housing for the motor
5452571 (Phoenix)			AMP 350780-1
4	U	Red	1
5	V	Yellow	2
6	W	Bleu	3
Grounding Screw	PE	Yellow/Green	4

Ensure U/V/W is wired in the order of RED/YELLOW/BLUE.

4.3 Encoder Connector CN3

4.3.1 Motor Encoder Feedback Cable Configuration

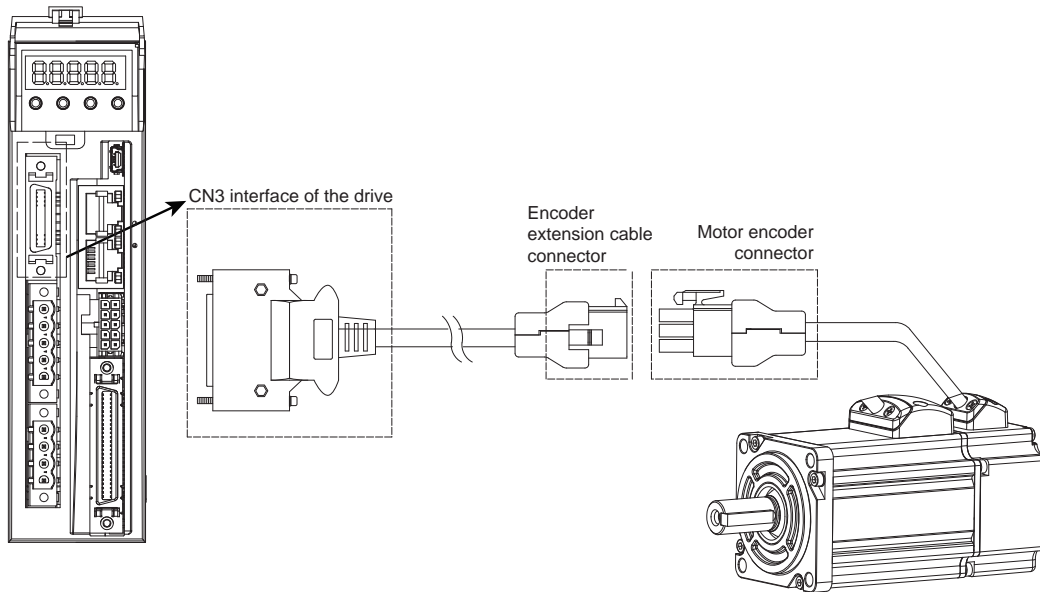

4.3.2 Layout of CN3 Connector

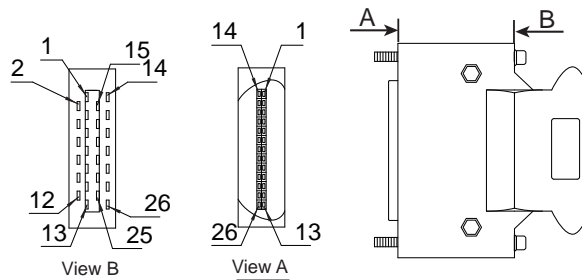

Pin NO.	Symbol	Description
1	A+	Encoder A+
2	B+	Encoder B+
3	Z+	Encoder Z+
4	U+	Hall U+
5	W+	Hall W+
6	U-	Hall U-
7	W-	Hall W-
11	Encoder +5V	Encoder power supply +5V
13	Encoder +5V	Encoder power supply +5V
14	A-	Encoder A-
15	B-	Encoder B-
16	Z-	Encoder Z-
17	V+	Hall V+
19	V-	Hall V-
24	GND	Encoder power supply ground
26	Shield	Shield

4.3.3. Connection to Motor Encoder

Connect to 2500ppr Increment Encoder (9PIN AMP connector)

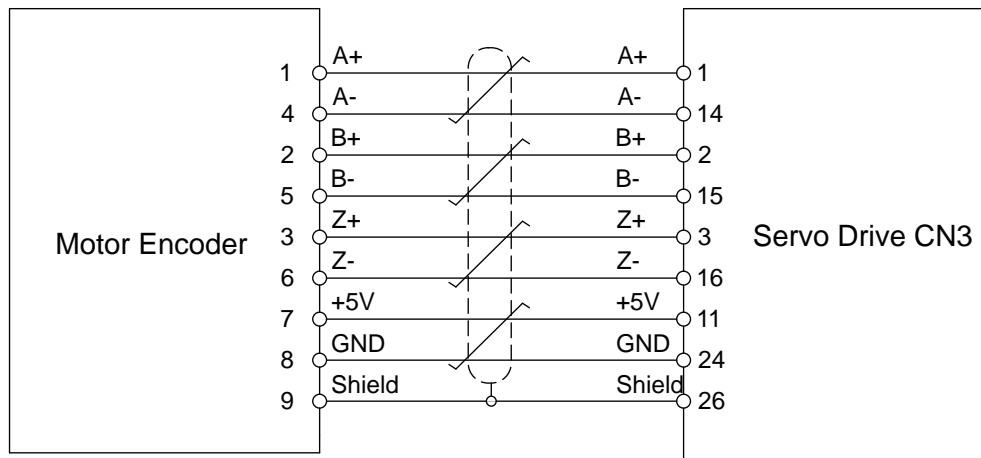

4.3.4 Specifications of Encoder Connector

A. -E4 Encoder Connector PIN Assignment

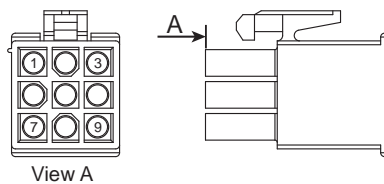

PIN#	Signal	Colour
1	U+/A+	Blue
2	V+/B+	Green
3	W+/Z+	Yellow
4	U-/A-	Yellow/Black
5	V-/B-	Green/Black
6	W-/Z-	Yellow/Black
7	+5V	Red
8	GND	Black
9	Shield	Shield

NOTE: The HALL signal U/V/W ONLY appears for short time after the encoder is powered on, it will then covert to A/B/Z signals.

B. -E4 Encoder Connector Specifications

Type	Motor Plug	Housing for the motor
Housing	AMP 172169-1	AMP 172161-1
Terminal	AMP 770835-1	AMP 770834-1

4.3.5 Motor Encoder Extension Cable Wiring Diagram

-E4 Encoder Encoder Cable Diagram

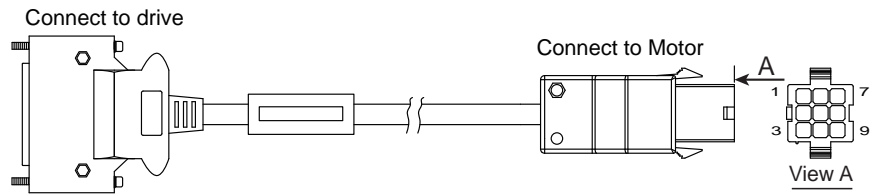

Drive Side	Signal	Color	Housing for the motor
TYCO 3-22322346-1 or equivalent			AMP 172161-1
1	A+/U+	Blue	1
2	B+/V+	Green	2
3	Z+/W+	Yellow	3
14	A-/U-	Yellow/Black	4
15	B-/V-	Green/Black	5
16	Z-/W-	Yellow/Black	6
11	+5V	Red	7
24	GND	Black	8
26	Shield	Shield	9

4.4 STO Connector

On the M2DC series servo drives, the STO (Safe Torque Off) function is connected via port CN5. The STO function shuts off the motor current turning off the motor output torque by forcibly turning off the signal of the servo driver power transistor. This is done internally through the STO Input/Output signal circuit.

4.4.1 Safety Precautions

- If the STO function does not trigger, make sure the STO connector is plugged into CN5 on the drive correctly.
- When using the STO function, perform an equipment risk assessment to ensure that the system conforms to the safety requirements.
- Even when the STO function is enabled, the servo motor may move due to external force (e.g. gravitational force on the vertical axis). Make sure a holding brake is used in applications where this is possible.
- When the STO function engages and removes the torque, the motor will be “free running”, requiring more distance until the motion stops. Make sure this will not be a safety issue.
- When the STO function operates, it will turn off the current to the motor, but it does not turn off the power to the servo drive. Make sure to disconnect the power to the drive before performing any maintenance on it.
- After the STO function is triggered, the drive will have a fault alarm status(Alarm code: **r20to**), and the motor will be disabled.
- After the STO signal return to normal, the drive will automatically clear the STO fault alarm, but the motor will remain disabled . To restore the system to normal operation, re-enable is needed.

4.4.2 STO Input/Output Signals

4.4.2.1 STO Internal Circuit Diagram

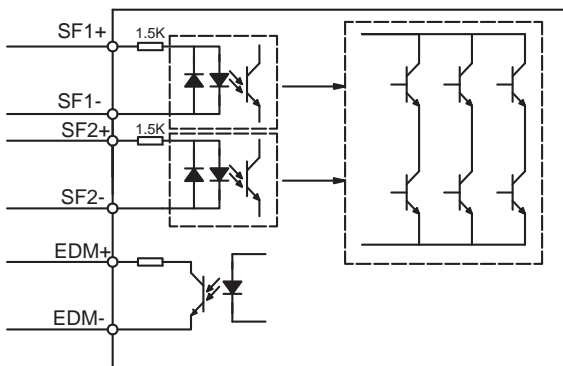

4.4.2.2 CN5 Connector diagram

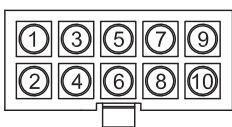

Item	Part number	Vendor
Housing	43025-1000	Molex
Crimp	43030-0005	Molex

4.4.2.3 STO Signal Definition

Signal	Symbol	Pin	Description	Control Mode
Safety Input SF1	SF1+	1	When SF1 has no input signal, e.g. the port is disconnected, SF1 will be considered OFF. The upper half of the internal power transistor will be shut off.	Compatible with all control modes
	SF1-	5		
Safety Input SF2	SF2+	3	When SF2 has no signal input, e.g. the port is disconnected, SF2 will be considered OFF. The upper half of the internal power transistor will be shut off.	
	SF2-	2		
Safety Output	EDM+	6	Output monitor signal used to check the safety function.	
	EDM-	4		
Ground	DGND	7, 8	+5VDC power ground	
+5V power	+5V	9, 10	+5VDC power supply	

4.4.2.4 STO Connection Diagrams

Connection to safety switch

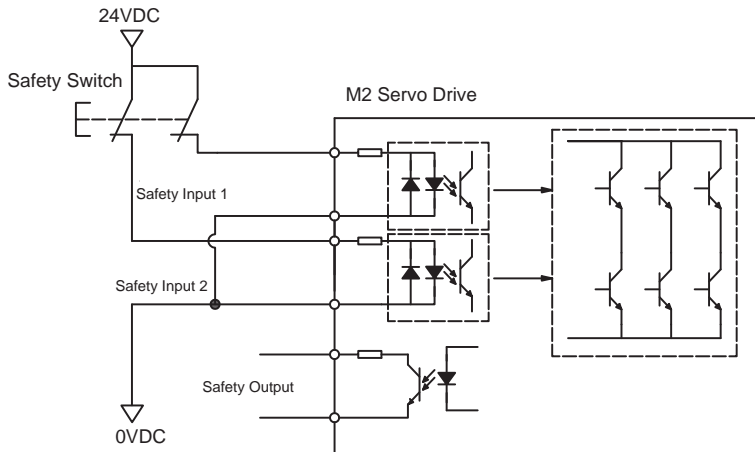

Safety light curtain connection

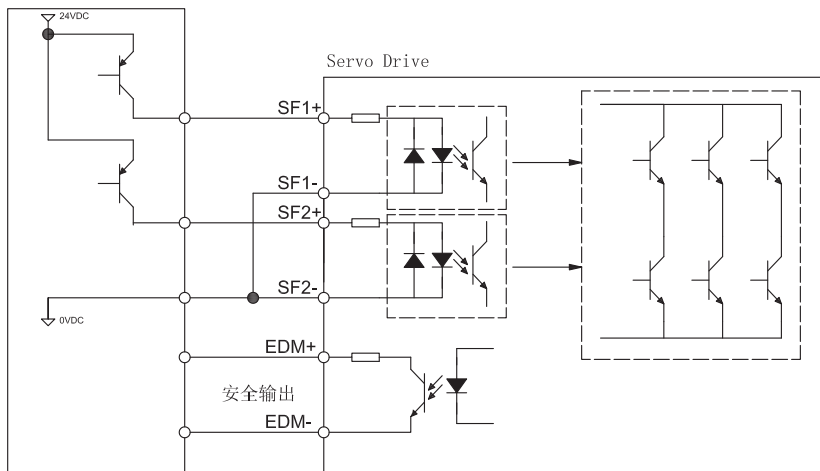

4.5 Electromagnetic Brake

When the motor drives the vertical axis, a brake should be used to hold and prevent the load from falling by gravity when the power is removed.

NOTE: Use only a servo motor brake for holding a load when the motor is disabled or the power is off. Never use a servo motor brake to stop a load in motion. This may cause damage to the servo motor.

4.5.1 Wiring Diagram

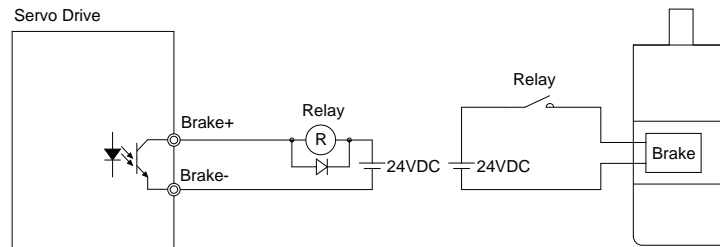

4.5.2 Brake Motor

- When no power is applied to the electromagnetic brake, it is in a locked position. Therefore, the motor shaft will not be able to rotate.
- The brake coil has no polarity.
- During the brake/release action, you might hear a clicking sound. This is normal and does not affect the use of brake.
- Specifications of the brakes are as follows:

Type	Motor Power				
	60W	100W	200W	400W	750W
Holding torque (N·m)	0.35		2		4.5
Working current (A)	0.25		0.38		0.61
Rated voltage (V)	24V±10%				
Release time	<25ms				
Engage time	<25ms				
Release voltage (V)	Release voltage 18.5VDC				

4.5.3 Timing Charts of the Electromagnetic Brake

In order to prevent damage to the brake, there are delay sequences during the brake operation. Please be cautious with brake operation sequence.

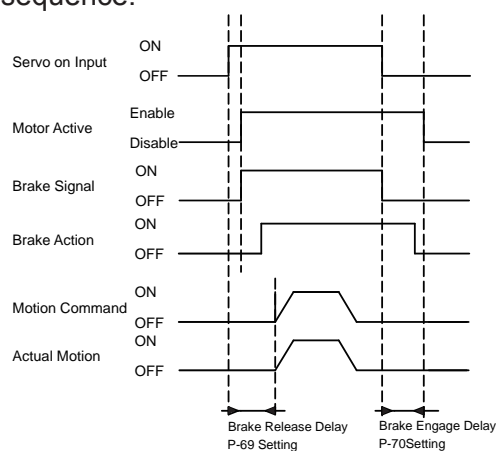

Brake engage/disengage delay time can be set through M Servo Suite software, or on the drive directly through the P function: P-69 (BD) or P-70 (BE).

4.6 Regeneration Resistor

In M2DC-6D5 or M2DC-10D servo drives, there is a pre-installed 20W regeneration resistor. In some applications, the pre-installed regeneration resistor might not be enough to absorb all foldback current and get a over-voltage fault. In these cases, a larger wattage regeneration resistor needs to be connected to P3 connector port externally, to prevent drive over voltage warnings.

4.6.1 Recommended external resistor

	Unit	Range
Resistance R	Ω	$5 \leq R \leq 10$
Power	W	>100

There is no pre-installed regeneration absorbing resistor internally in M2DC-20D drive. Please do connect an external absorbing resistor to P3 port.

4.6.2 Regeneration Resistor Configuration

The following steps show how to configure the regeneration resistor.

1. Run the M Servo Suite software
2. Click the Drive button of the menu and select Misc.Setting

M Servo Suite V1.0.18.0321

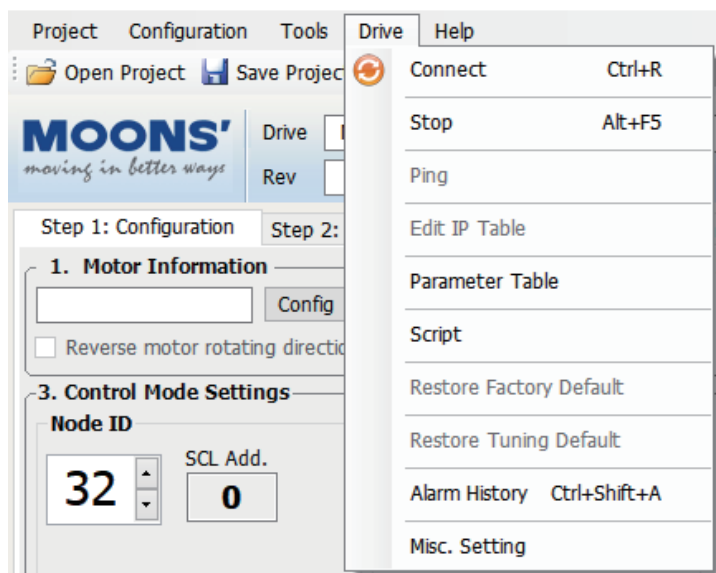

3. Enter the parameters of the regen-resistor

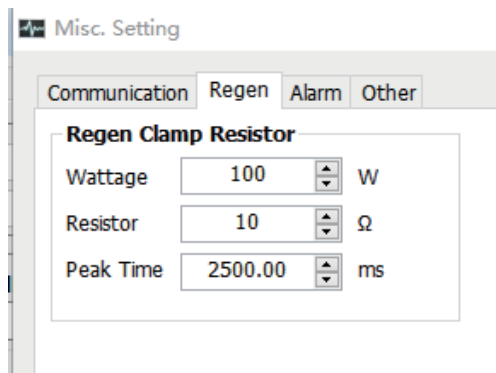

Wattage: The regeneration resistor wattage. M2DC drives calculate the continuous wattage induced into an external regeneration resistor and must know the continuous wattage rating of the regen resistor to do this effectively.

Resistor: The regeneration resistor value. M2DC drives dynamically calculate the continuous wattage induced into an external regeneration resistor and must know the value of the regen resistor to do this effectively.

Peak Time: The regeneration resistor time constant. Calculates the peak time that the resistor can tolerate full regeneration voltage. The time is scaled as period count. One period is 250us.

4.7 Recommended Cable Specifications

- Select wires with sufficient allowance for parameters such as operating current and ambient temperature.
- Recommended wire selections are as follows:

Servo Drive And Corresponding Motor Model	Wire Width mm ² (AWG)	
	V+/V-	U/V/W
M2DC-6D05	1.5 (AWG15)	0.75 (AWG18)
M2DC-10D5	2.5 (AWG13)	1.25 (AWG16)
M2DC-20D5	2.5 (AWG13)	3.5(AWG12)

4.8 Connecting to the Host Computer - CN1

Port CN1 is used to connect the drive with a PC. Use M Servo Suite software to set the control mode, change parameter values, use the auto-tuning function, etc.

PIN	Symbol	Function
1	+5V	+5V Power Supply
2	D-	Data -
3	D+	Data +
4	—	Reserved
5	GND	Ground

4.9 Input and Output Signal Interface Connector - CN2

4.9.1 Input and Output Interface Specifications and Diagram

Port CN2 on the M2DC series servo drives is used for input/output signals. Details are shown in table below:

I/O Signals	Digital Signal	Inputs	8 Configurable optically isolated general inputs, 5-24VDC, 20mA 4 Configurable optically isolated high speed inputs
		Outputs	4 Configurable optically isolated general outputs, max 30VDC, 20mA 1 Alarm output, max 30VDC, 20mA 1 motor brake control output, max 30VDC, 20mA
	Analog Signal	Inputs	2 Analog inputs, with 12 bit resolution
	Pulse Signal	Inputs	2 optically isolated high speed inputs 500KHz (open collector) 2 high speed differential inputs 2MHz
		Outputs	4 high speed encoder feedback outputs (3 line driver A/B/Z, and 1 open collector output Z)

4.9.2 Signal Description of Connector CN2

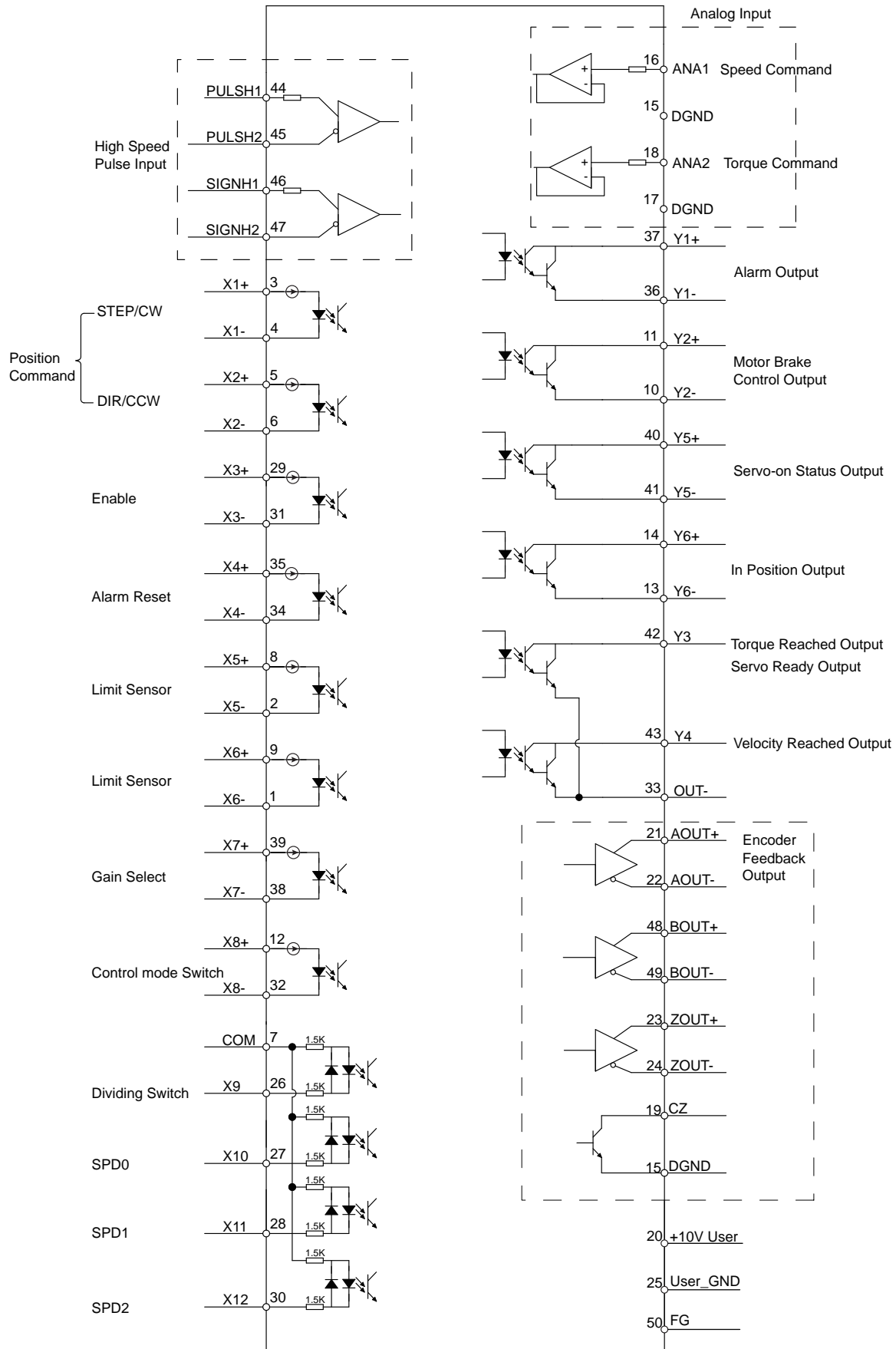

4.9.2.1 Layout of CN2 Connector

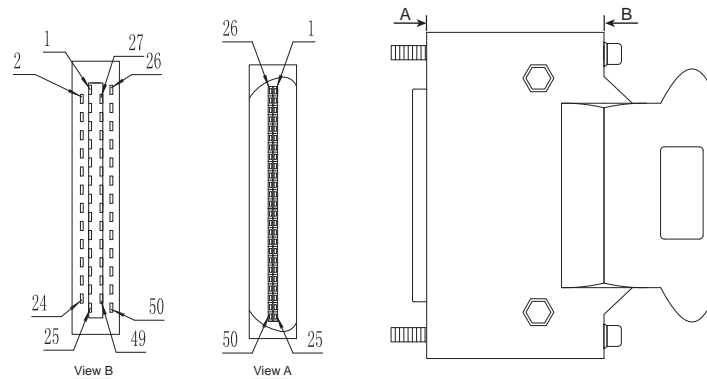

4.9.2.2 Input Signals

The M2DC series servo drive has 12 programmable digital inputs as well as 2 analog inputs.

Each of the inputs can be specified with different functions via the parameter settings. The functions are as follows:

- Specified function signals: i.e. STEP/DIR signal, motor enable/disable signals.
- General purpose signal: In velocity mode, torque mode, Q program mode, or SCL mode, it is used as general purpose signal with no specified functions.

Signal	Symbol	Pin NO.	Details
X1	X1+	3	This input has three functions: <ul style="list-style-type: none"> • Accept STEP pulse input such as STEP signals, CW pulse, A pulse in position mode • Run/Stop input in torque or velocity mode • General purpose input
	X1-	4	
X2	X2+	5	This input has three functions: <ul style="list-style-type: none"> • Accept STEP pulse input such as Direction signals, CCW pulse, B pulse in position mode • Direction input in torque or velocity mode • General purpose input
	X2-	6	
X3	X3+	29	<ul style="list-style-type: none"> • Enable/Disable input • General purpose input
	X3-	31	
X4	X4+	35	<ul style="list-style-type: none"> • Alarm reset input, used to reset drive alarm • General purpose input
	X4-	34	
X5	X5+	8	<ul style="list-style-type: none"> • Limit sensor input • General purpose input
	X5-	2	
X6	X6+	9	<ul style="list-style-type: none"> • Limit sensor input • General purpose input
	X6-	1	
X7	X7+	39	<ul style="list-style-type: none"> • Gain select input in pulse position mode • General purpose input
	X7-	38	
X8	X8+	12	<ul style="list-style-type: none"> • Switch control mode between main mode and second mode • General purpose input
	X8-	32	
X9	X9	26	<ul style="list-style-type: none"> • Dividing switch, change the pulses per revolution for electronic gearing • General purpose input
X10	X10	27	<ul style="list-style-type: none"> • Pulse inhibited input - ignores the pulse input when this input is activated in position mode
			<ul style="list-style-type: none"> • Speed selecting input 1 in change speed mode • General purpose input
			<ul style="list-style-type: none"> • Speed selecting input 2 in change speed mode • General purpose input
X11	X11	28	<ul style="list-style-type: none"> • Speed selecting input 3 in change speed mode • General purpose input
X12	X12	30	<ul style="list-style-type: none"> • Speed selecting input 3 in change speed mode • General purpose input
COM	COM	7	X9-X12 COM point

High-Speed Pulse Inputs	PULSH1	44	High-speed pulse inputs (+5VDC line drive input), the maximum input frequency 2MHz. Three pulse commands available: <ul style="list-style-type: none"> • Pulse & Direction • CW Pulse and CCW Pulse • A Quadrature B pulse (NOTE: DO NOT use with both X1 and X2)
	PULSH2	45	
	SIGNH1	46	
	SIGNH2	47	
Analog Input Signal 1	ANA1	16	In analog velocity control mode, the offset, dead band, and function of analog input 1 can be set by M Servo Suite or parameters P-52, P-56 and P-61. <ul style="list-style-type: none"> • Sets or requests the analog input gain that relates to motor position when the drive is in analog position command mode • Sets or requests the gain value used in analog velocity mode • General analog input in Q mode
	DGND	15	Digital Ground for analog input
Analog Input Signal 2	ANA2	18	In analog torque control mode, the offset, dead band, and function of analog input 2 can be set by M Servo Suite or parameters P-53, P-57 and P-61. <ul style="list-style-type: none"> • General analog input in Q mode
	DGND	17	Digital ground for analog input

4.9.2.3 Input Function List

	1	2	3	4	5	6	7	8	9	10	11	12
Step	■											
DIR		■										
CW Limit					•							
CCW Limit						•						
Start/Stop	▲▼											
Direction		▲▼										
Servo enable			•									
Alarm clear				•								
Speed selection 1,2,3										▲	▲	▲
Global gain selection							■					
Control mode selection								•				
Pulse encoder Resolution selection									■			
Pulse Inhibit										■		
General Input	•	•	•	•	•	•	•	•	•	•	•	•

■ – Position Mode ▲ – Velocity Mode ▼ – Torque Mode • – All Modes

4.9.2.4 Output Signals

The M2DC series servo drive has 6 programmable digital output signals available; each of the outputs can be specified with a different function via parameter settings.

Signal	Symbol	Pin NO.	Details
Y1	Y1+	37	This output has two functions: <ul style="list-style-type: none"> Alarm Output General purpose output
	Y1-	36	
Y2	Y2+	11	This output has two functions: <ul style="list-style-type: none"> Motor brake control output General purpose output
	Y2-	10	
Y3	Y3+	42	<ul style="list-style-type: none"> Torque Reached Output Servo ready output- output servo ready signal when the drive is ready to be controlled and without alarm General purpose output
	Y3-	33	
Y4	Y4+	43	<ul style="list-style-type: none"> Moving signal output - output signal when the dynamic position error is less than the set value in position mode Velocity reach output - output signal when the actual speed is the same as the target speed and the speed ripple less than the ripple range General purpose output
	Y4-	33	
Y5	Y5+	40	<ul style="list-style-type: none"> Servo-on Status output --output signals when the motor is enabled. General purpose output
	Y5-	41	
Y6	Y6+	14	<ul style="list-style-type: none"> In position signal output - output signal when in position, and the position error is less than the set value in position mode Tach out output - produces pulses relative to the motor position with configurable resolution General purpose output
	Y6-	13	
Encoder pulse feedback Output	AOUT+	21	The encoder feedback phase A line drive output
	AOUT-	22	
	BOUT+	48	The encoder feedback phase B line drive output
	BOUT-	49	
	ZOUT+	23	The encoder feedback phase Z line drive output
	ZOUT-	24	
ZOUT	19	The encoder feedback phase Z output (open collector)	
+10V Output	+10V User	20	+10VDC user, max 100mA
	USER_GND	25	+10VDC user ground

4.9.2.5 Output Function List

Output Pin		Y1	Y2	Y3	Y4	Y5	Y6
Function	Alarm Output	•					
	In Position error						•
	Dynamic Position error				■		
	Tach Out						•
	Brake		•				
	Torque Reach			•			
	Servo Ready			•			
	Servo-On Status					•	
	Velocity Reach					▲▼	
	General Output	•	•	•	•	•	•

■ – Position Mode ▲ – Velocity Mode ▼ – Torque Mode • – All Modes

4.9.3 Input Signal Interface Connector, CN2

4.9.3.1 Position pulse signal input

The M2DC series servo has two high speed pulse inputs, STEP/DIR and PULSH/SIGNH. STEP/DIR supports 5-24VDC, up to 500KHz open collector input signal or differential input signal through the line driver. PULSH/SIGNH supports 5VDC, up to 2MHz with differential line driver input.

NOTE: STEP/DIR and PULSH/SIGNH CANNOT be used at the same time.

A. Open Collector Input Signal Diagram

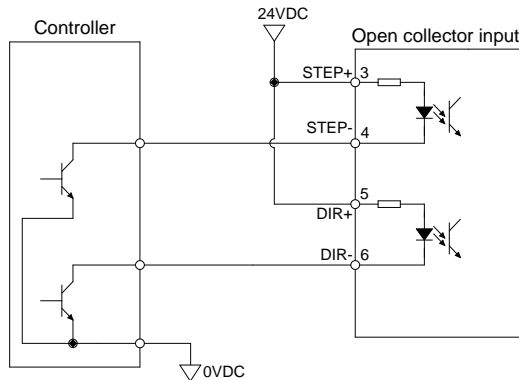

B. Differential Input Signal Diagram

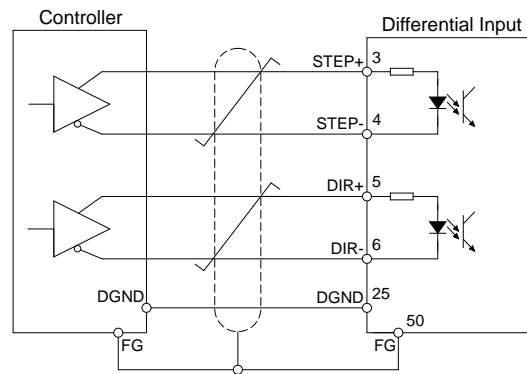

C. High Speed Differential Signal Input Diagram



Use ONLY 5V supply for PULSH/SIGNH input, DO NOT use 24V.

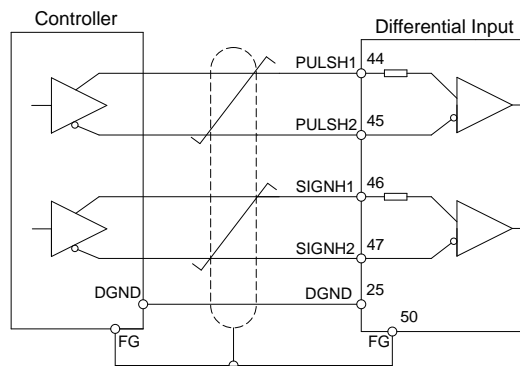

D. Pulse Input Description

- STEP/DIR Pulse Input

When both STEP and DIR input signals are ON, the motor will rotate in one direction.

When STEP input signal is ON, and DIR input signal is OFF, the motor will rotate in the opposite direction.

The direction signal (DIR) can be configured via M Servo Suite software.

The following graph represents motor rotation in CW direction when DIR input is ON.

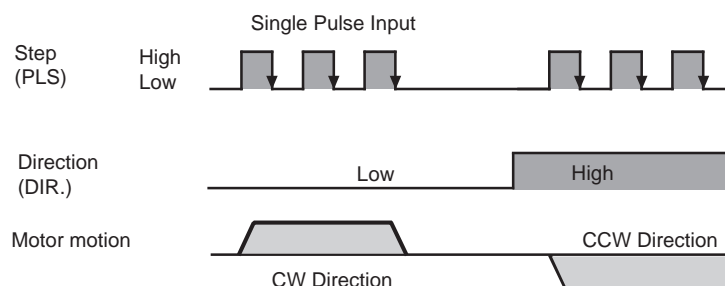

● CW/CCW Pulse

When Pulse input goes into X1, the motor will rotate in one direction.

When Pulse input goes into X2, the motor will rotate in the opposite direction.

Motor direction can be configured via M Servo Suite software.

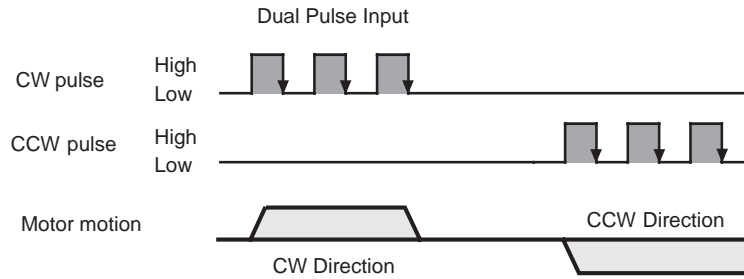

● A/B Quadrature

In A/B Quadrature mode, the motor rotary direction is based on the leading signal between A and B.

Motor rotary direction can be configured via M Servo Suite software. Direction is defined by the leading input between X1/X2.

The following graph represents motor rotates in CW direction when X1 is leading X2.

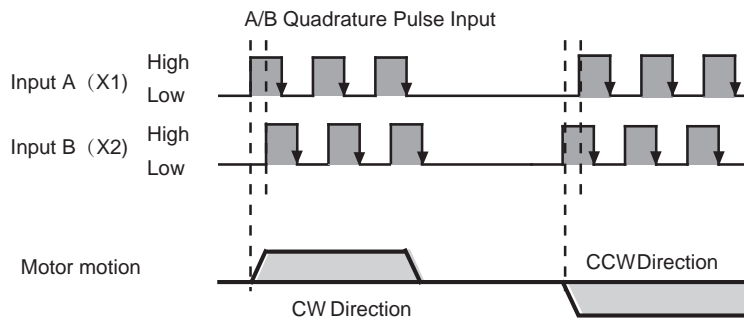

4.9.3.2 Analog Signal Input For Velocity And Torque Mode

The M2DC series servo drive has 2 single ended analog inputs OR 1 differential analog input. The input voltage range is -10V to +10V. Velocity and torque range can be configured via M Servo Suite software.

Single Ended Analog Input

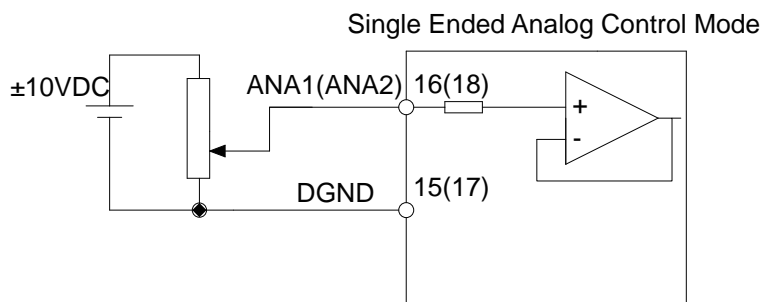

Differential Analog Input

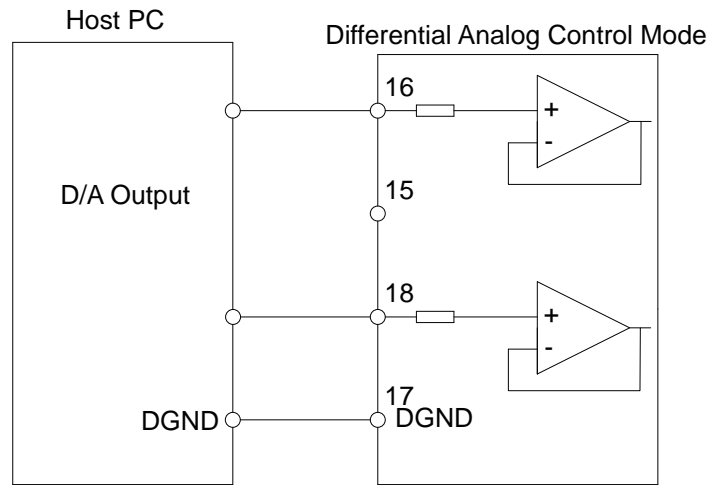

4.9.3.3 High Speed Input Ports X1, X2, X3, X4

High Speed Input Port

The M2DC has 4 optically isolated high speed digital inputs X1, X2, X3, and X4. These inputs allow input voltage from 5VDC to 24VDC with maximum current of 20mA, and up to 500KHz. They can be used for general purpose inputs, connecting sensor switch signals, PLC controllers or other types of controller output signals.

NOTE: When the drive is in position mode, X1, X2 can ONLY be set as STEP/DIR signal.

When the drive is NOT in position mode, X1, X2 can be set as general purpose signals.

X1, X2, X3, X4 circuits are as follows:

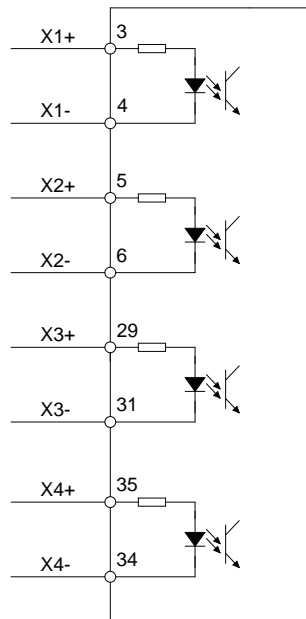

High Speed Input Connection Diagrams

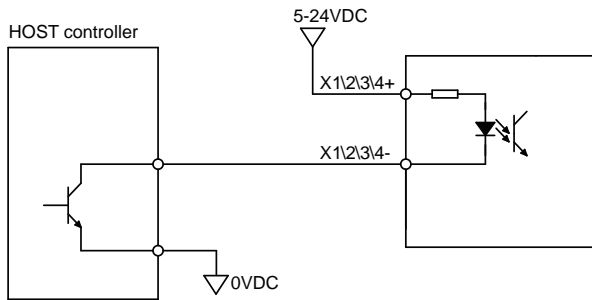

Host Sink Mode

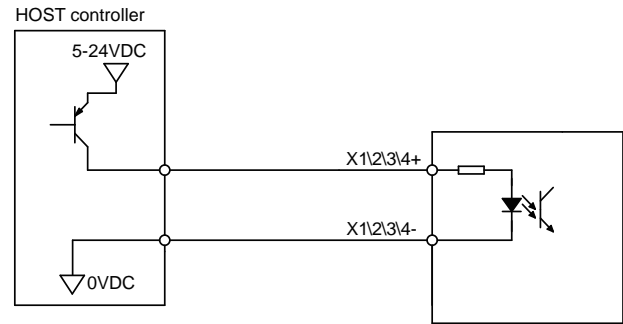

Host Sourcing Mode

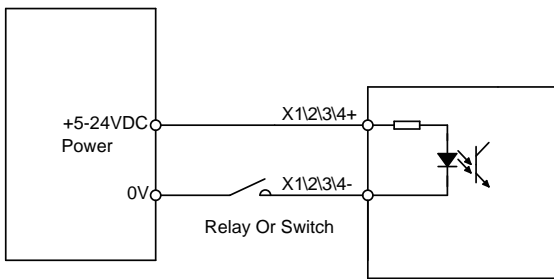

Sensor And Switch Connection

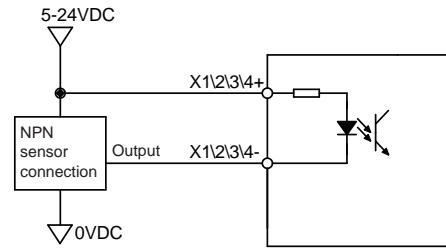

NPN Sensor Connection

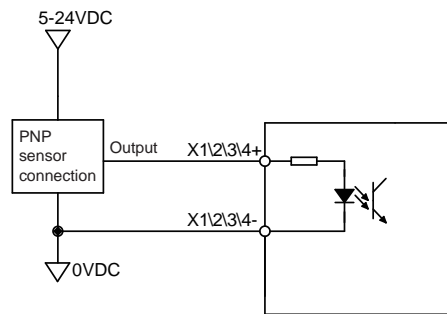

PNP Sensor Connection

4.9.3.4 General Digital Input X5, X6, X7, X8

The M2 has 4 optically isolated general digital inputs X5, X6, X7 and X8. These inputs allow input voltage from 5VDC to 24VDC, with maximum input current of 20mA up to 5KHz. Both single ended and differential signals are allowed.

X5, X6, X7, X8 circuits are as follows:

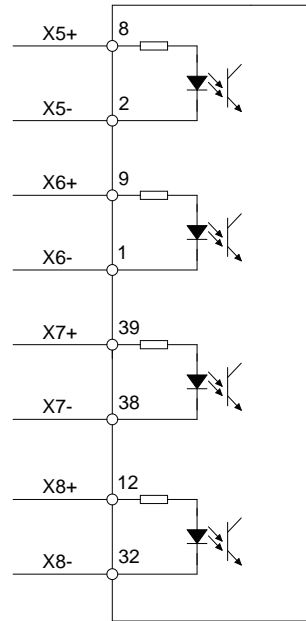

X5, X6, X7, X8 Input Port Connection Diagrams

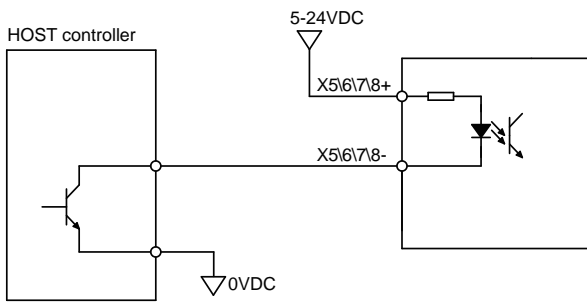

Host Sink Mode

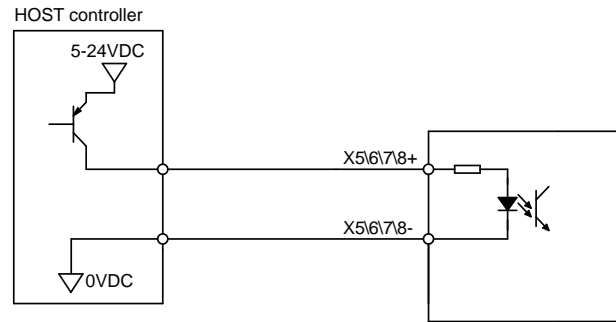

Host Sourcing Mode

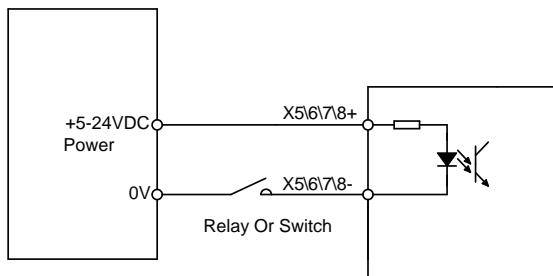

Sensor And Switch Connection

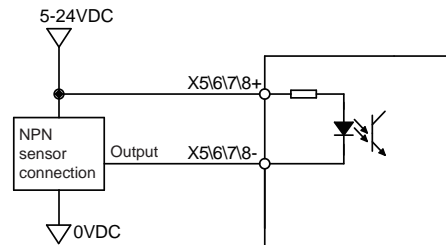

NPN Sensor Connection

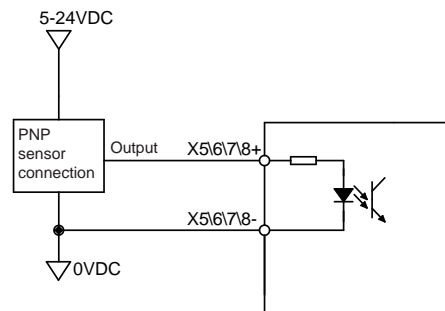

PNP Sensor Connection

4.9.3.5 X9, X10, X11, X12 Inputs with common COM Port

The M2 drives also have 4 single ended optically isolated inputs connected with a single common node named 'COM'. These inputs can be used with sourcing or sinking signals, 12-24V. This allows for connection to PLCs, sensors, relays and mechanical switches. Because the input circuits are isolated, they require a source of power. If you are connecting to a PLC, you should be able to get power from the PLC power supply. If you are using relays or mechanical switches, you will need a 12-24V power supply.

What is COM?

“Common” is an electronics term for an electrical connection to a common voltage. Sometimes “common” means the same thing as “ground”, but not always. If you are using sinking (NPN) signals, then COM must connect to the power supply +. If you are using sourcing (PNP) input signals, then you will want to connect COM to ground (power supply -).

NOTE: If current is flowing into or out of an input, the logic state of that input is low or closed. If no current is flowing, or the input is not connected, the logic state is high or open.

X9, X10, X11, X12 circuits are as follows:

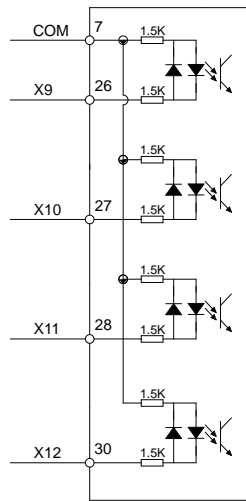

X9, X10, X11, X12 Input Port Connection Diagrams

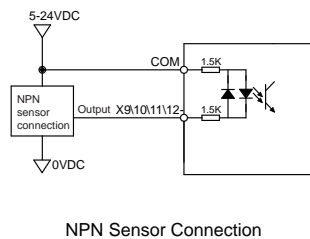
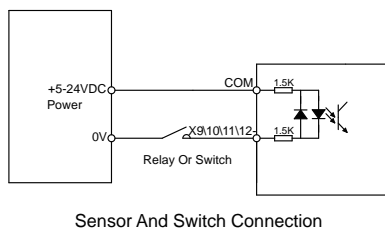
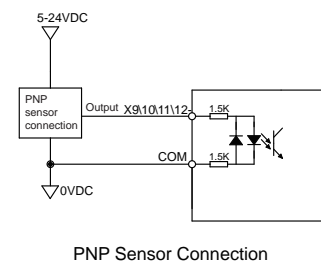
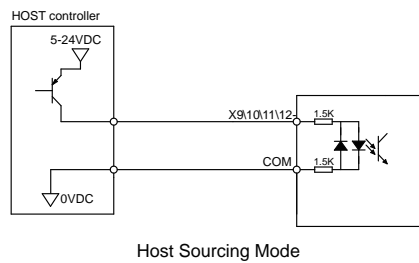
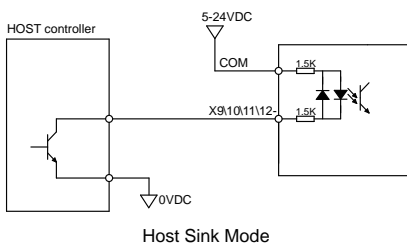

4.9.4 CN2 Output Signal Specification

The M2DC series servo drives feature 6 optically isolated digital outputs. They can be configured via M Servo Suite. Y1, Y2, Y5, and Y6 are differential output signals, they can be used for both sourcing or sinking signals. Y3 and Y4 are common ground outputs that can be used for sinking signals.

Output circuits are as follows:

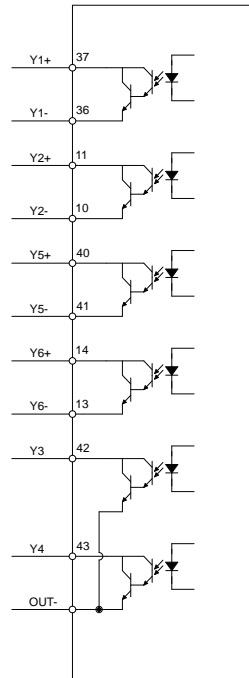

Y1, Y2, Y5, Y6 Output Connection Diagrams

NOTE: Y1, Y2, Y3, Y4, Y5 and Y6 maximum outputs are 30VDC 30mA.

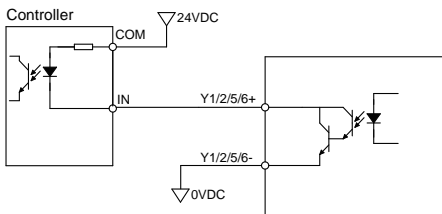

Opt Coupler Circuitry

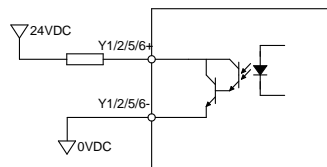

Connect To External Load

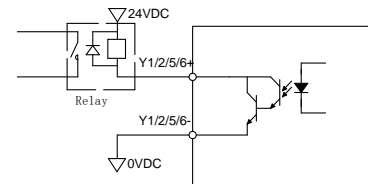

Connect To Relay Circuitry

Y3, Y4 Connection Examples

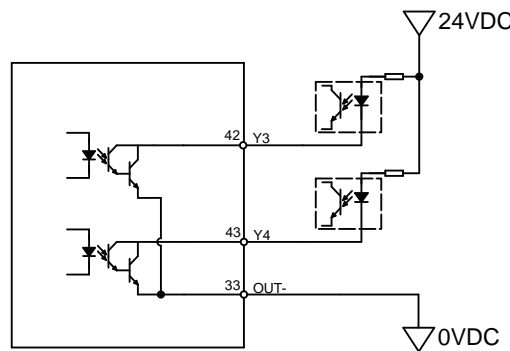

4.9.5 Encoder Feedback Output

The M2DC series servo drive can output encoder A/B/Z phase as differential output signals through the line driver. The output signal is 5V, A/B signals are 10000 pulse/rev, Z signal is 1 pulse/rev.

The host must use the line receiver to receive these signals. Use twisted-pair wires for signal transfer.

4.9.5.1 A/B/Z Connection Diagram

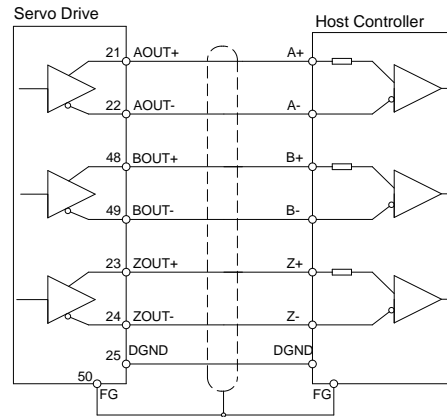

NOTE: Please make sure the host controller and the servo drive are connected to a common ground.

4.9.5.2 Z Phase Open Collector Output

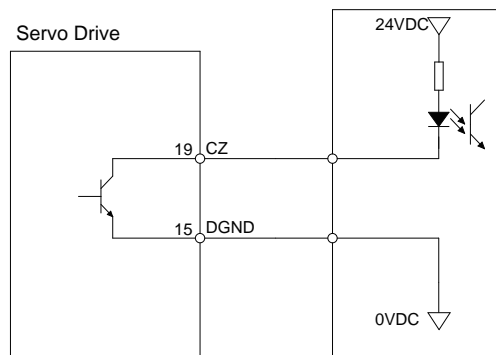

On the M2 drives, encoder signal Z uses open collector output circuitry. Due to the narrow bandwidth of encoder signal Z, please use high speed opto-coupler circuitry for the host receiver.

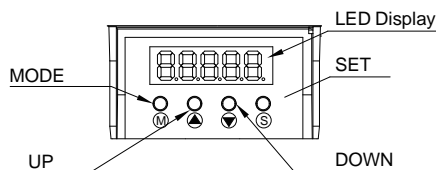

5 Display and Operation

5.1 Control Panel Description



Symbol	Name	Details
	LED Display	The LCD display (5 digits, 7 segments) shows the drive's operating condition, warning codes, parameters, and setting values.
	MODE	Press and hold MODE button to switch the LED display mode a) Monitoring selection mode b) Function selection mode c) Parameter setting mode When editing the parameters, press the MODE button to move the cursor to the left and then change the parameters by using the UP/DOWN buttons.
	UP/DOWN	Press the UP and DOWN buttons to scroll through and change monitor codes, parameter groups and other parameter settings.
	SET	Press to enter a mode Press and hold to save parameters/settings



5.2 Mode Switch Control

- Pressing the **M** button and the **S** button changes between status monitoring, function control, parameters setting and other modes.
- If no warnings or faults occur, the drive will not go into warning and fault display mode.
- If any warnings are detected by the drive, the LED display will switch into warning or fault display mode immediately. Pressing Mode/Set button will switch back to the previous display mode. Press UP/DOWN button will switch other warning or fault display.
- If no button(s) on the control panel is pressed for 20 seconds, the display will switch back to the previous status monitoring display mode.
- In monitoring selection mode, function selection mode and parameter setting mode, to edit the values, press **M** to move the cursor to the left, then change parameters by using the **▲** **▼** buttons.
- In status monitoring mode, press and hold the **S** button to lock the control panel. To unlock the panel, press and hold the **S** button again.

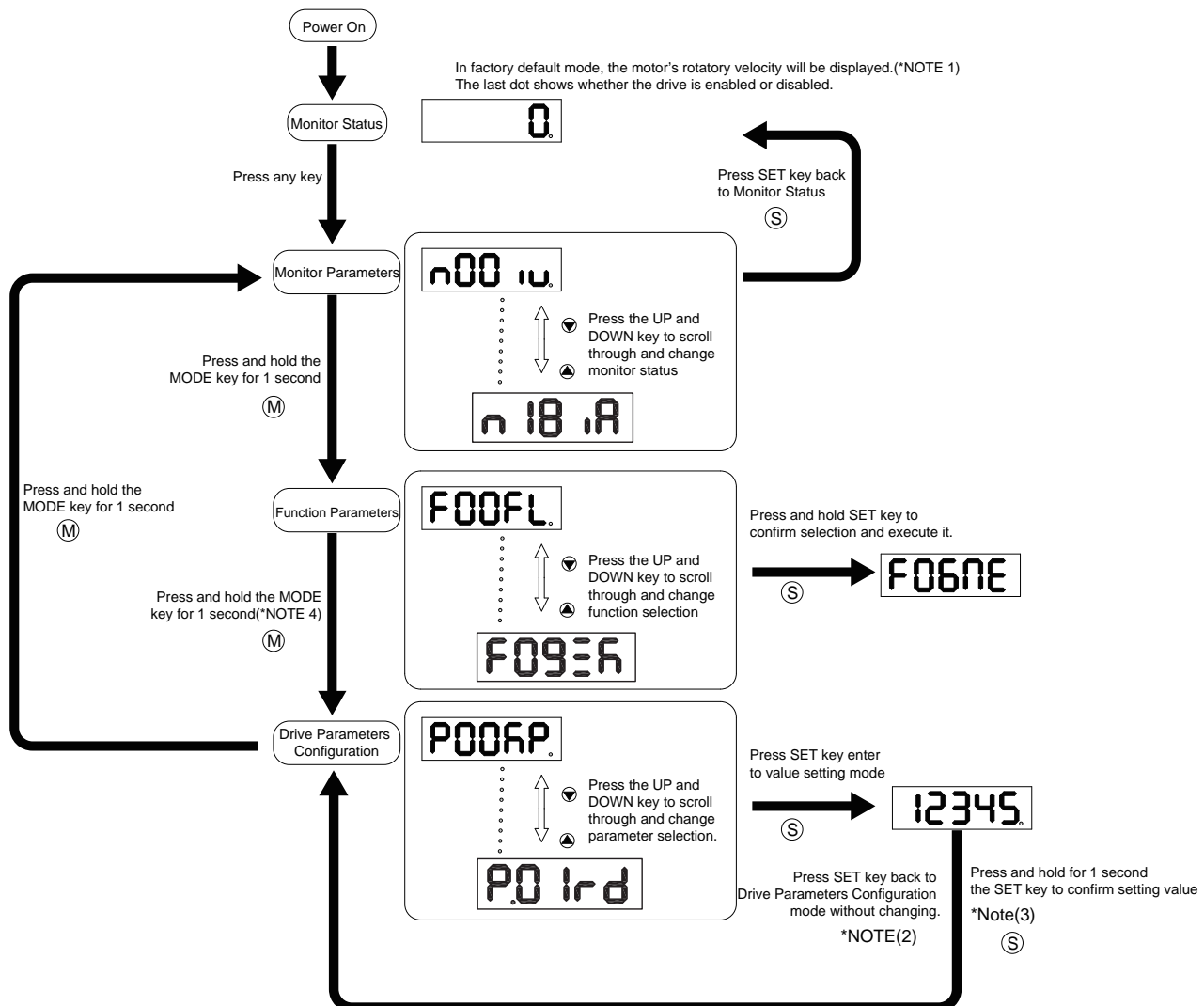
Control mode switch flowchart:





NOTE:

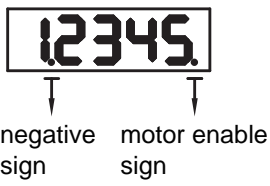

- When power is applied, the drive’s display will show the customer defined monitoring mode. In factory default mode, it will display the motor’s rotary velocity.
- When in parameter setting mode, pressing the  button will exit the parameter setting mode, and return back to parameter selection mode, without saving any changes.
- When in parameter setting mode, pressing and holding the  button will confirm and apply the current parameter setting. This will take effect immediately. However, this change will not save to drive’s flash memory. To save the parameter, go to function mode **F04ER**, and then press and hold the  button.
- When the drive is connected to the host computer with M Servo Suite on, the parameter setting mode CANNOT be accessed directly on the drive’s control panel.

5.3 LED display description



5.3.1 Decimal Point And Negative Sign Description

LED display	Description
	<p>Negative sign: when the value to be displayed is a negative number ≥ -9999, the highest digit will display as a negative sign. </p> <p>Decimal point: when the value to be displayed is a negative number ≤ -10000, a decimal point will be displayed. </p>



5.3.2 Parameter View Setting

LED display	Description
	<p>There are only 5 digits on the LED display, when a value with more than 5 digits needs to be displayed, it will be displayed in 2 segments. When the highest digit of a value is flashing, it means only the lower 5 digits are shown. Press  to display the upper 5 digits. The graph is displaying ‘-12802345’</p>

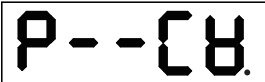

5.3.3 Parameter Save Setting

LED display	Description
	<p>In parameter setting mode, pressing and holding the  button will save the change. ‘Saved’ will also be displayed on the LED.</p>
	<p>In parameter setting mode when the motor is rotating and the is pressed and held, the LED display will read “busy” meaning that the current parameter change cannot be saved. Stop the current motor motion and save the parameter again.</p>





5.3.4 Point To Point Motion Mode

LED display	Description
	When the LED display reads "P-CW" it means the motor is rotating in a CW direction in the point-to-point mode.
	When the LED display reads "P-CCW" it means the motor is rotating in a CCW direction in the point-to-point mode.

5.3.5 Jog Mode

LED display	Description
	When the LED display reads "J-CW" it means the motor is rotating in a CW direction in JOG mode.
	When the LED display reads "J-CCW" it means the motor is rotating in a CCW direction in JOG mode.

5.3.6 Control Panel Lock



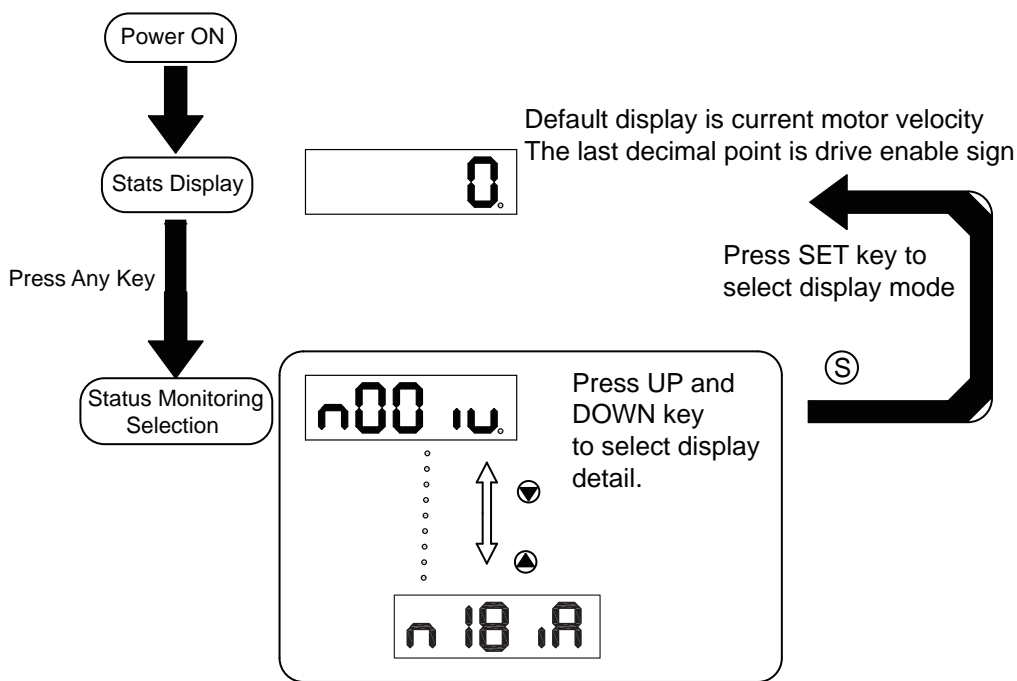

LED display	Description
	This means the key panel is locked. Press and hold  for 1 second while in status monitoring mode to lock.
	When the control panel is locked, press and hold  for 1 second to unlock it.

5.4 Status Monitoring Selection Mode

To change the status monitoring mode, press **(M)** to enter monitoring selection mode, and then use **(▲)** **(▼)** to make selections, and press **(S)** to confirm, as below:



N mode selection and setting	LED display	Description	Unit
n-00	n00 i.u.	Motor Rotation Speed	RPM
n-01	n01 .h.	Position Error	Pulse
n-02	n02 L.E.	Pulse Counter	counts
n-03	n03 .E.	Encode Counter	counts
n-04	n04 .P.	Command Position Counter	counts
n-05	n05 .t.	Drive Temperature	x 0.1°C
n-06	n06 .U	DC Bus Voltage	x0.1V
n-07	n07 dA	Node ID (Drive Address)	
n-08	n08 A H	Fault History 1	

n-09		Fault History 2	
n-10		Fault History 3	
n-11		Fault History 4	
n-12		Fault History 5	
n-13		Fault History 6	
n-14		Fault History 7	
n-15		Fault History 8	
n-16		Differential Analog Input	0.001VDC
n-17		Analog Input 1	0.001VDC
n-18		Analog Input 2	0.001VDC

5.5 Function Control Mode

In function control mode (display F+ parameter number), you can select functions for preoperational mode, restart the drive, enable or disable the drive, etc. In status monitoring mode, press and hold **M** for 1 second to enter function control mode. Press **▲** **▼** to select function, and then press and hold **S** to confirm or execute the function. (NOTE: F-00(FL) and F-01(CJ) excepted)

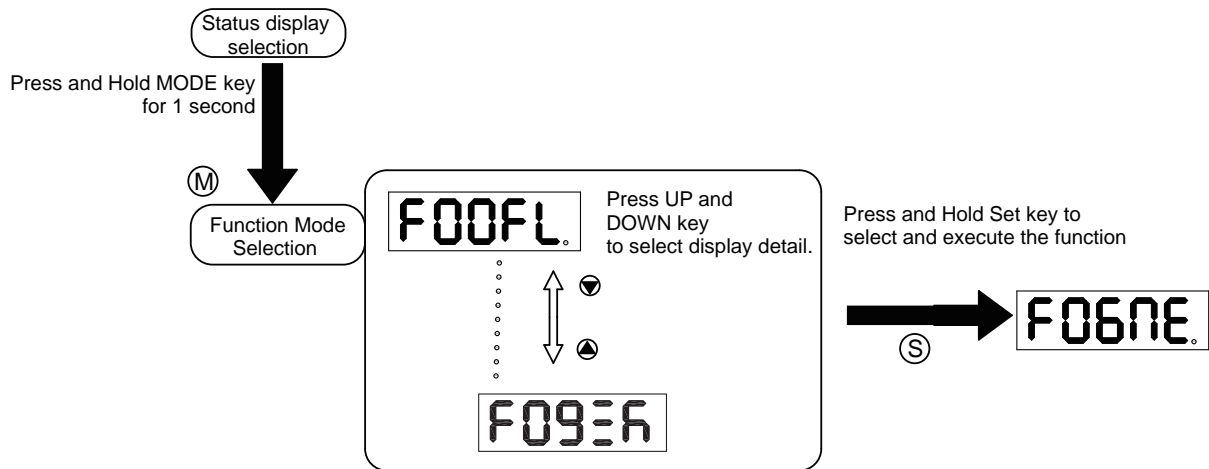

5.5.1 Function Mode Description

Function mode details are as follows:

Function mode number	LED display	Description
F-00	F00FL	point to point position mode: rotating speed is 1 rps; travel distance is 1 rev
F-01	F01CJ	JOG mode: JOG speed 1 rps
F-02	F02rE	Restart the drive
F-03	F03Ar	(F-03AR) Clear drive's current alarm
F-04	F04rA	(F-04SA) Save parameter changes for P-00 to P-98
F-05	F05Nd	(F-05MD) Drive disable
F-06	F06NE	(F-06ME) Drive enable
F-07	F07nC	(F-07MC) Select motor specification
F-08	F08Ar	(F-08AZ) Analog auto tuning
F-09	F09rK	(F-09SK) Motion Stop/Q Stop

5.5.2 Operation Flow Chart

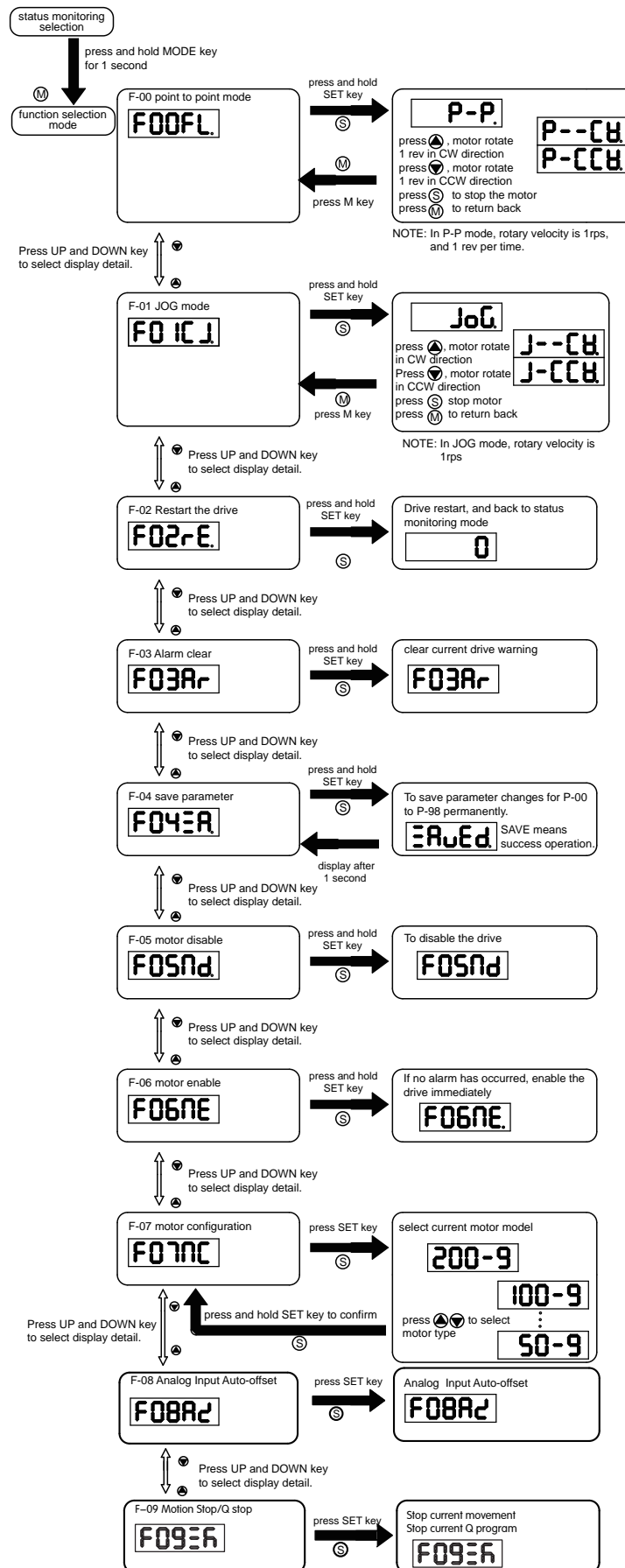

5.6 Parameter Setting Mode

5.6.1 Parameter Setting Description

The parameter setting mode (P+parameter number) allows you to select, display and edit the required parameter. In function control mode, press and hold **M** for 1 second to enter parameter setting mode.

Use **▲** **▼** to select required parameter, and press **S** to view or edit the parameter. Press **S**

again to quit and no change will be saved. Press and hold **S** for 1 second to save the parameter change. However this change will NOT be saved at the next power on.

If you want to save parameter PERMANENTLY, go into function control mode (F+parameter number), and use F-04SA function.

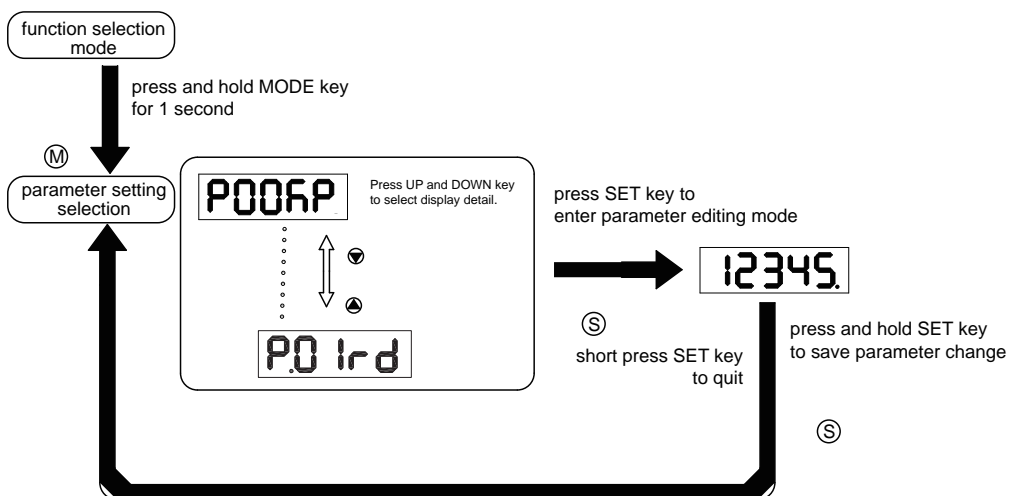

5.6.2 Parameter Editing Examples

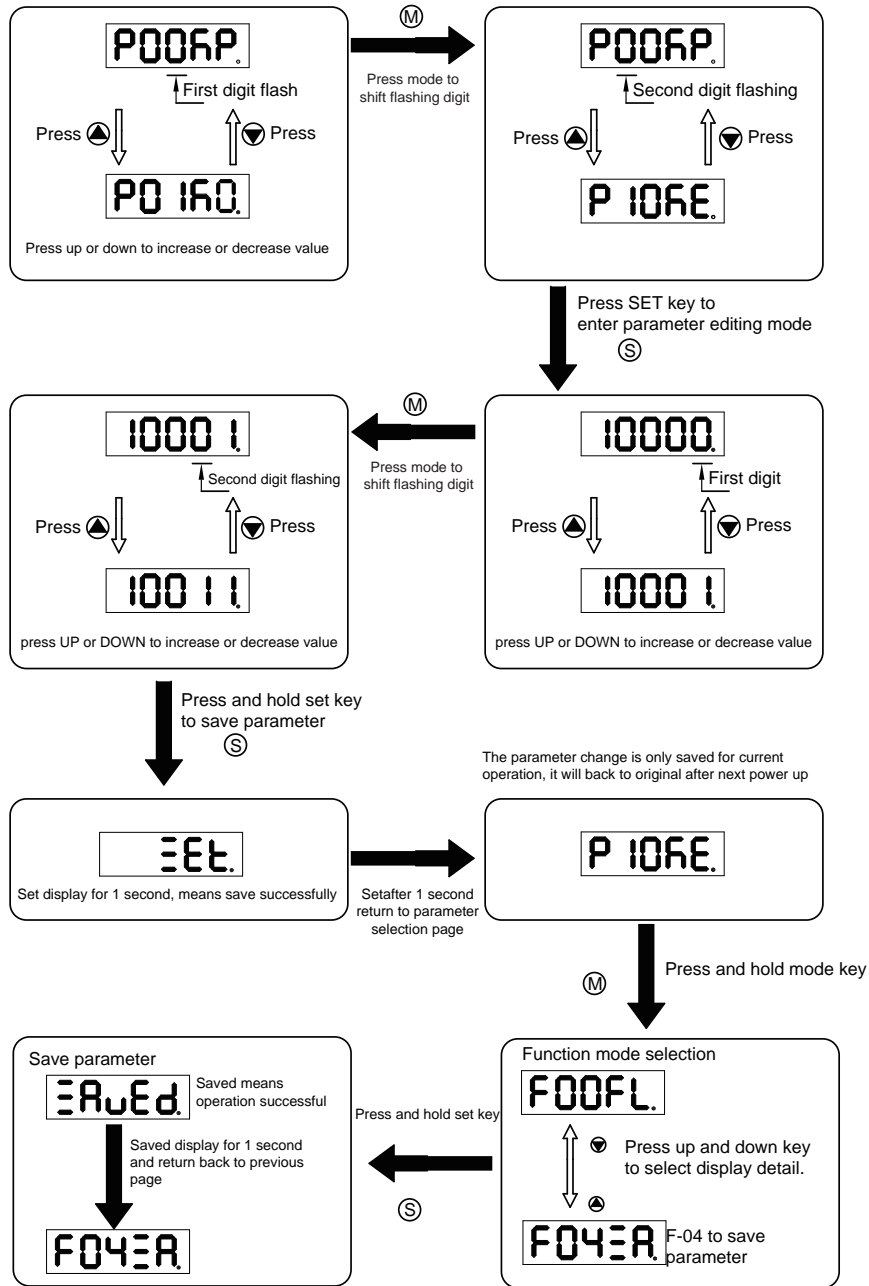

5.7 Control Panel Lock

To prevent unauthorized use of the key panel, a key panel lock is featured on all M2DC servo drives. When the panel is locked, no function can be changed directly on drive's control panel.

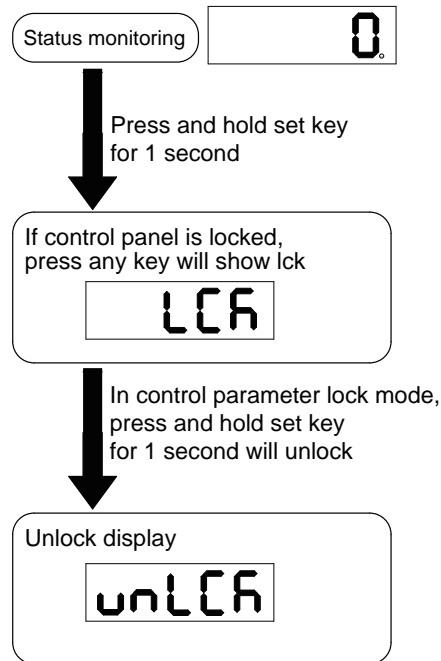

5.8 Warning And Fault Display

When power is applied, if any warnings are detected by the drive, the LED display on the drive will switch into warning or fault display mode immediately.

If more than one warning is detected, pressing the buttons will scroll through the warnings. Press the or button to clear the warning display and return to the previous display mode.

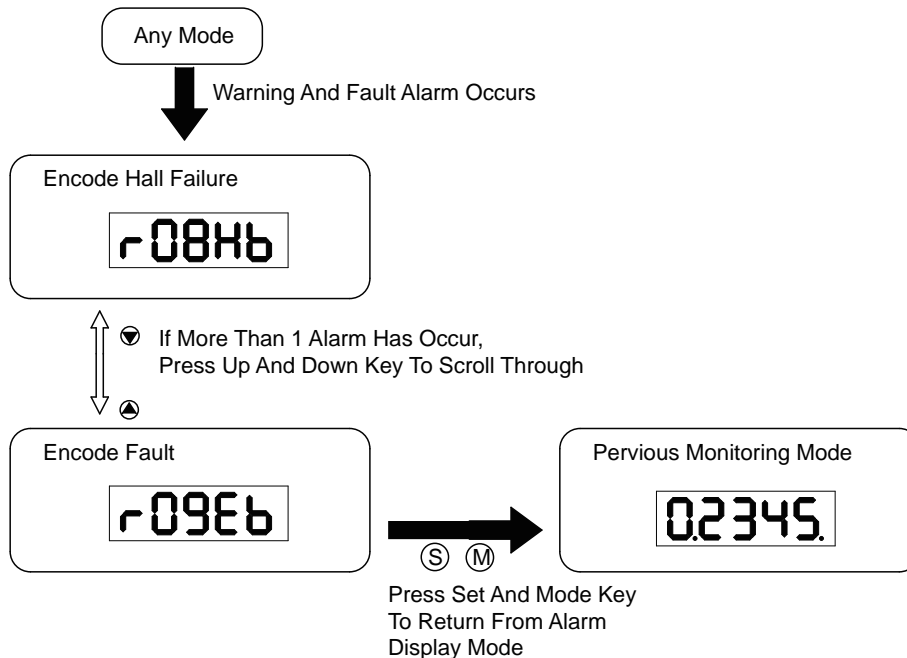

LED display	Description	LED display	Description
r01ot	Drive over temperature	r14LL	CW limit is activated
r02ur	Internal voltage fault	r15JL	CCW limit is activated
r03uH	Over voltage	r16CL	Current limit
r04HC	Over current	r17CE	Communication error
r05LC		r18EF	Parameter save failed
r06rC		r20to	STO is activated
r08Hb	Bad hall sensor	r21rF	Regeneration failed
r09Eb	Encoder error	r22uB	Low voltage
r10PL	Position error	r239E	Q program is empty
r11Lu	Low voltage	r24dd	Motion command received while motor in disabled
r12ou	Velocity limited		
r13Lt	CW limit or CCW limit activated		

6 Preoperational mode



When using preoperational mode, disconnect the servo motor from any mechanical system to prevent damages and accidents. Preoperational mode should be used only under a no load condition.

6.1 Inspection Before Trial Run

To avoid any accidents and damages to the servo drive and mechanical systems, the following safety checks are recommend before the drive is turned on.

- Connection inspections
 - Ensure secure wiring for power connector P1, motor connector P2, encoder connector CN3, and communication connector CN1. Check the wiring connections, and that wires are correctly insulated (to avoid short circuits) for all connectors.
 - Make sure the ground wire from power connector P1, and motor connector P2 are securely connected to the shield ground.
- Power supply inspection - Ensure the power supply to V+ and V- meet the drive's power supply specifications.
- Check that the servo drive and motor are securely installed.
- Make sure no load is connected to the servo motor.

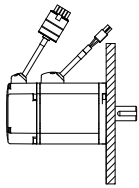
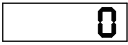
6.2 Trial Run Procedure

Step	Details	Description
1	Install the motor securely. 	<ul style="list-style-type: none"> - The motor can be installed on the machine. - Ensure no load is installed on the servo motor.
2	Make sure the wiring between the drive and motor is correct.	<ul style="list-style-type: none"> - The terminals on connector P2 must be connected in the order of U - Red, V - Yellow, U - Blue, FG - Yellow/Green. If the terminals are not connected to the specified wire, the drive will not be able to control the motor. - Ensure the encoder cable is connected to CN2 correctly.
3	Make sure the main power circuit is wired correctly.	Refer to Section 4.1 Connecting to Peripheral Devices to confirm the correct main power circuit wiring.
4	Supply power	Do not apply more than 75V power supply to the servo system.
5	If there are no alarms the LED Display will read:  If an alarm occurs, it will display:  	<ul style="list-style-type: none"> - When the power is on, the normal display should be shown without any alarm codes and the drive is disabled. - If the display shows alarm codes such as r-08 and r-09 the encoder feedback connection is incorrect. Check the encoder wiring to the servo motor to see if it is loose or incorrect. - See Section 10.1 for a list of alarm codes.
6	Set up a motor brake control circuit if using an electromagnetic brake motor.	Please refer to Section 4.4 for more details about the Electromagnetic Brake.
7	Motor Configuration	Configure the drive for the correct motor through M Servo Suite or the operation panel. See Section 6.3 Motor Configuration.
8	JOG Trial Run without load	The system is ready to run JOG trial if all the above steps are completed.

6.3 Motor Configuration







Before using JOG mode, the drive needs to be properly configured for the connected motor. This can be done through the drive control panel or the M Servo Suite software. For more details about motor specifications, refer to Section 2.3.

6.3.1 Using the Drive Control Panel for configuration

Motor information and LED display list:

LED display	Motor Model Number	LED display	Motor Model Number
60-9	SM0401HE4-KCD-*NV	60L9	SM0401EE4-KCD-*NV
100-9	SM0402FE4-KCD-*NV	200L9	SM0601EE4-KCD-*NV
200-9	SM0601GE4-KCF-*NV		
400-9	SM0602FE4-KCF-*NV		
400L9	SM0602GE4-KCF-*NV		
300-9	SM0801GE4-KCF-*NV		
550-9	SM0802EE4-KCF-*NV		
750-9	SM0803GE4-KCF-*NV		

To set up a drive for model: SM0402FE4-KCD-NNV motor follow these steps:

Step	LED display	Description
1	FOOFL	Press  to enter Function Parameters mode when in Monitor Status mode
2	F07n	Press the  and  key to select F07 (MC)
3	200-9	Press  to enter the value setting mode
4	100-9	Press  or  key to change the value
5	≡AUEd	Press and hold  key for 1 second to confirm motor configuration
6	F07n	
		Parameter will take effect only after the servo drive is restarted.

6.3.2 Using M Servo Suite Software for configuration

Run the M Servo Suite software on a PC, and (1) select the correct communication port.

Use the drive configuration tab (2) to set up the motor.

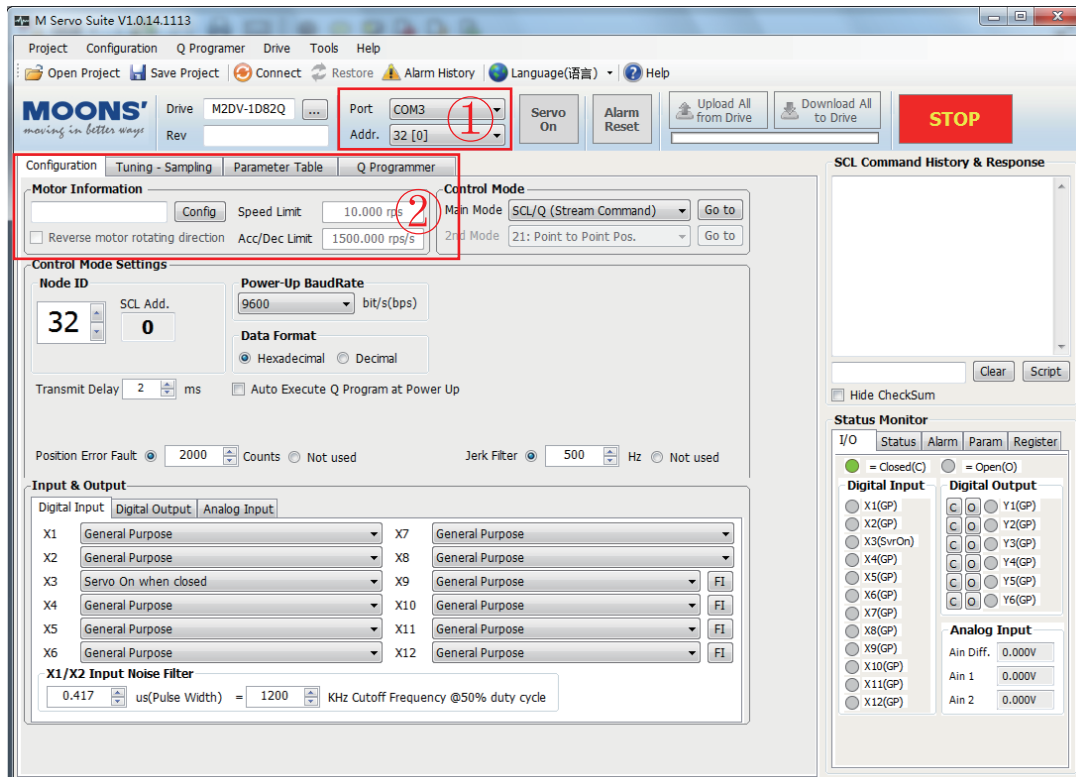

Click the Config button to bring up the Motor Select screen:

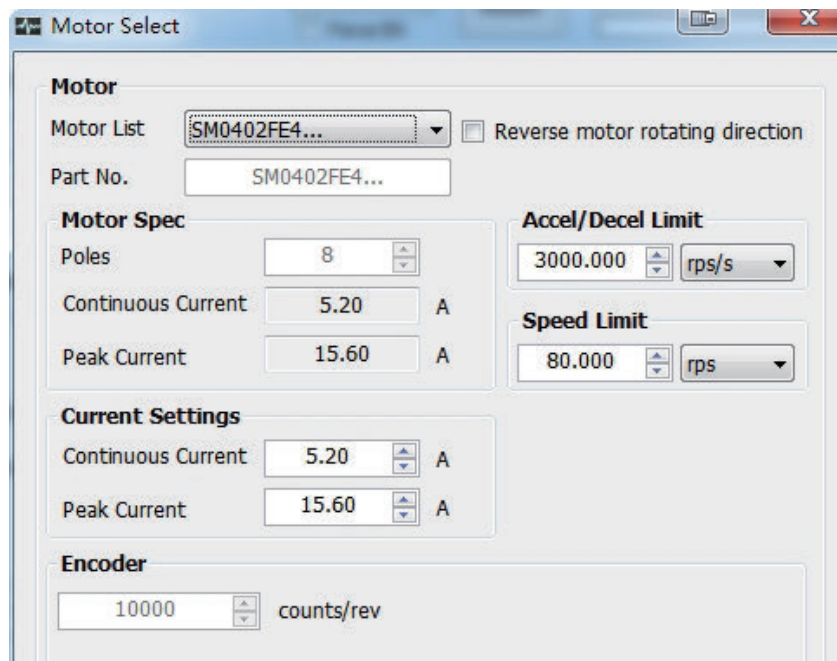

After setting the required parameters, click OK and then Download All to Drive to save the settings to the drive.

6.4 Operations of JOG Mode

Step	LED display	Description
1	P00RP	Press M to switch from Monitor Status mode to the Drive Parameters Configuration mode
2	P6 E .	Scroll with the ▲ ▼ keys to select parameter P62 (SI)
3	2	Press S key to enter the value setting mode
4	3	Scroll with the ▲ ▼ keys to change values
5	E E t	Press and hold the S key for 1 second to confirm the set value
6	F00FL	Press the M key to enter Function Operation mode
7	F06NE	Scroll with the ▲ ▼ keys to select Function F06 (MC) to enable the motor
8	F06NE.	Press and hold SET key for 1 second, to enable the drive. The last dot will appear to show the drive is enabled.
9	F0 IC J	Scroll with the ▲ ▼ keys to find function F01 (CJ) to run JOG mode.
10	JOG	Press the S key to enter JOG mode
11	J--C8	Press the ▲ key and the motor will rotate in a CW direction at 1rps.
12	J-CC8	Press the ▼ key and the motor will rotate in a CCW direction at 1rps.
13	JOG	Press the S key to stop the motor
14	F0 IC J	Press the M key to get back to the Function Operation mode.

6.5 Configuration by Personal Computer

To ensure the M2DC servo drive and motor meet operational requirements, it is recommended that the M Servo Suite software is used for the following configuration setups:

- Servo motor model selection and configuration
- Operational mode selection
- Defining the drive's input/output mode
- Applying the auto tuning function on PID parameters for optimized motor performance.

For more information on the M Servo Suite's capabilities, please refer to the software manual.

Connecting to a PC:

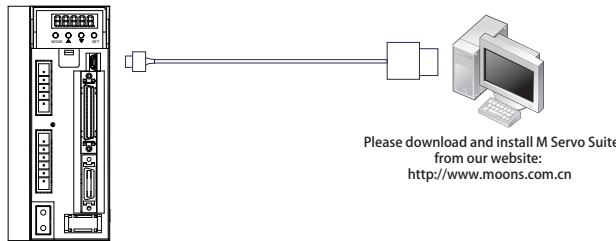

M Servo Suite Interface

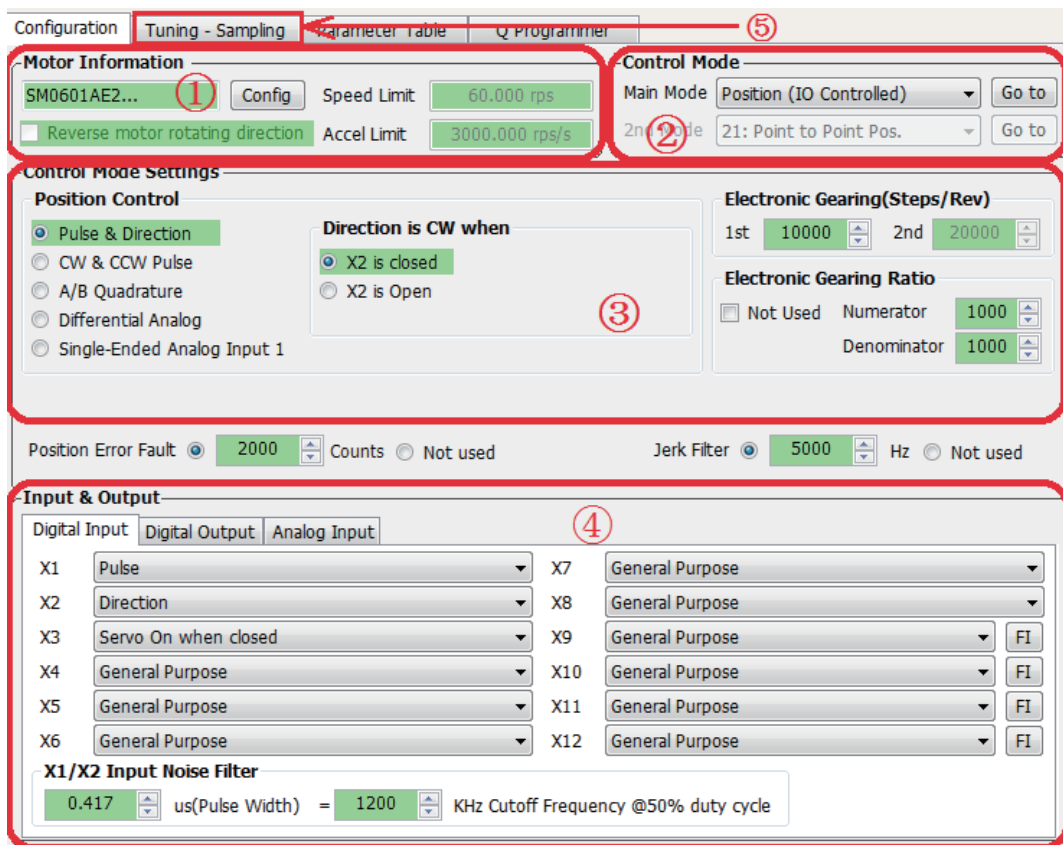

Configuration Steps	Details
Step 1	Motor Configuration
Step 2	Select Control Mode
Step 3	Further configuration
Step 4	I/O configuration
Step 5	Tuning

7 Operation Mode Selection

7.1 General Function Settings

7.1.1 Drive Servo On Settings

To control servo motor enable/disable switch

1) Servo ON signal

By default, the Servo ON input (X3) is configured as follows:

Signal Name	PIN (CN2)	Condition	Function
X3	29 (X3+)	Closed	Servo motor enable Servo ON
	31 (X3-)	Open	Servo motor disable Servo OFF

2) Definition for Servo On signal

Parameters P-62 (SI) and P-14 (PM) can be changed

A. When P-14 (PM) = 2, parameter settings are as follows:

P-14 (PM)	P-62 (SI)	Condition	Function
P-14 (PM) = 2 (default)	1	Closed	If P-14 (PM)=2 and P-62 (SI)=2, driver will enable at power-up, and then switch to disable
		Open	Servo Enable
	2 (default)	Closed	Servo motor enable Servo ON
		Open	Servo motor disable Servo OFF
	3		Enable servo motor when powered ON

B. When P-14 (PM) = 5, the parameter settings are as follows:

P-14 (PM)	P-62 (SI)	Condition	Function	
P-14 (PM) = 5	1	Closed	Servo motor disable Servo OFF	
		Open	Servo motor enable Servo ON	
	2 (default)	Closed	Servo motor enable Servo ON	
		Open	Servo motor disable Servo OFF	
		3		Servo motor disable when power ON

NOTE: If P-14 (PM)=5, regardless of P-62 (SI) settings, the drive will be disabled (Servo OFF) at power up. Use input X3 to enable based on P-62 (SI) setting.

The default Power-up Mode (PM) setting (P-14) is set to a value of 5, which will cause the servo drive to power up disabled for safety during setup and configuration. This setting may be changed in the M Servo Suite software with the X3 digital input configuration. It may also be changed using the front panel on the servo drive with parameter P-14 or by using the PM command directly (see Host Command Reference manual for details on the PM command.)

Software Configuration

On the Drive Configuration page - Input & Output, select X3 function to set up.

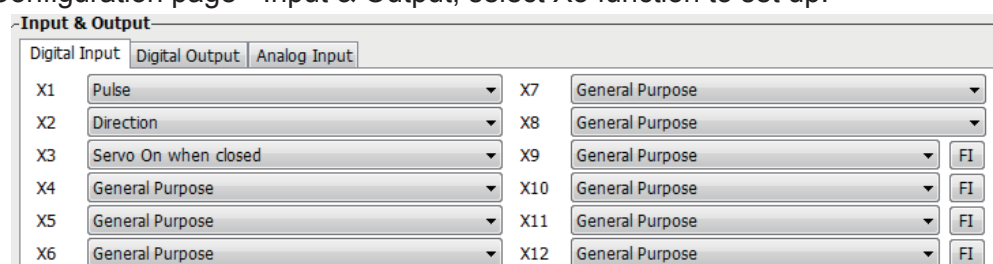

7.1.2 Alarm Reset

The Alarm Reset is used to clear drive warnings or faults and is set via P-63 (AI)

Signal Name	PIN (CN2)	P-63 (AI)	Function	
X4	35 (X4+) 34 (X4-)	1	<p>During normal operation, input X4 must be kept Open (HIGH). Clearing the alarm status will ONLY occur when X4 transitions from HIGH to LOW. When X4 changes from Open (HIGH) to Closed (LOW), the warning or fault alarms will be cleared.</p>	
			<p>1) X4 at HIGH, alarm NOT cleared 2) At point A, X4 changes from HIGH to LOW, alarm is cleared</p>	<p>1) X4 is low, alarm NOT cleared 2) At point A, X4 changes from LOW to HIGH, alarm NOT cleared 3) At point B, X4 changes from HIGH to LOW, alarm is cleared</p>
		2	<p>During normal operation, input X4 must be kept CLOSED (LOW). Clearing the alarm status will ONLY occur when X4 transitions from LOW to HIGH. When X4 changes from CLOSED (LOW) to OPEN (HIGH), the warning or fault alarms will be cleared.</p>	
			<p>1) X4 at LOW, alarm NOT cleared 2) At point A, X4 changes from LOW to HIGH, alarm is cleared 3) At point B, X4 changes from HIGH to LOW, the alarm does not clear</p>	<p>1) X4 is HIGH, alarm NOT cleared 2) At point A, X4 changes from HIGH to LOW, alarm NOT cleared 3) At point B, X4 changes from LOW to HIGH, alarm is cleared</p>
3 (default)		General purpose input		

Software Configuration

On the Drive Configuration page - Input & Output, select X4 functions to set up.

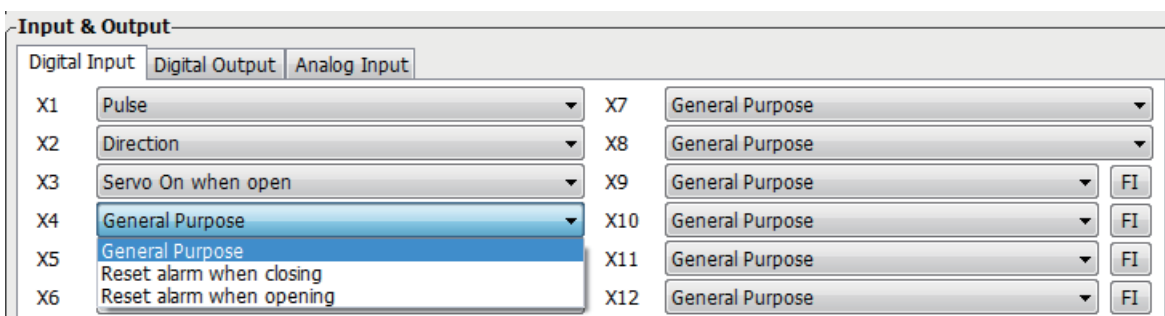

7.1.3 CW/CCW limit

In order to prevent damage that might be caused by mechanical hardware accidentally moving out of range, it is highly recommended that the CW/CCW position limits be configured by using external end-of-travel sensors connected to inputs X5 and X6.

P-64 (DL)	Description	Condition	Signal Name	Function
1, 4	X5 sets CW limit X6 sets CCW limit Stops motion when X5/X6 is closed	Closed	X5	Stops motion in CW direction, CW limit warning ON
			X6	Stops motion in CCW direction, CCW limit warning ON
		Open	X5	Rotates in CW direction as normal
			X6	Rotates in CCW direction as normal
2, 5	X5 sets CW limit X6 sets CCW limit Stops motion when X5/X6 is open	Closed	X5	Rotates in CW direction as normal
			X6	Rotates in CCW direction as normal
		Open	X5	Stops motion in CW direction, CW limit warning ON
			X6	Stops motion in CCW direction, CCW limit warning ON
3, 6, 13, 16	X5, X6 as general purpose input (default)			
7	X5 sets CW limit Stops motion when X5 is closed X6 as general purpose input	Closed	X5	Stops motion in CW direction, CW limit warning ON
		Open	X5	Rotates in CW direction as normal
8	X5 sets CW limit Stops motion when X5 is open X6 as general purpose input	Closed	X5	Rotates in CW direction as normal
		Open	X5	Stops motion in CW direction, CW limit warning ON
9	X6 sets CCW limit Stops motion when X6 is closed X5 as general purpose input	Closed	X6	Stops motion in CCW direction, CCW limit warning ON
		Open	X6	Rotates in CCW direction as normal
10	X6 sets CCW limit Stops motion when X6 is closed X5 as general purpose input	Closed	X6	Rotates in CCW direction as normal
		Open	X6	Stops motion in CCW direction, CCW limit warning ON
11, 13	X6 sets CW limit X5 sets CCW limit Stops motion when X5 is closed	Closed	X6	Stops motion in CCW direction, CCW limit warning ON
			X5	Stops motion in CCW direction, CCW limit warning ON
		Open	X6	Rotates in CW direction as normal
			X5	Rotates in CCW direction as normal
12, 16	X6 sets CW limit X5 sets CCW limit Stops motion when X5 is open	Closed	X6	Rotates in CW direction as normal
			X5	Rotates in CCW direction as normal
		Open	X6	Stops motion in CW direction, CW limit warning ON
			X5	Stops motion in CCW direction, CCW limit warning ON
17	X6 sets CW limit Stops motion when X6 is closed X5 as general purpose input	Closed	X6	Stops motion in CW direction, CW limit warning ON
		Open	X6	Rotates in CW direction as normal
18	X6 sets CW limit Stops motion when X6 is open X5 as general purpose input	Closed	X6	Rotates in CW direction as normal
		Open	X6	Stops motion in CW direction, CW limit warning ON
19	X5 sets CW limit Stops motion when X5 is closed X6 as general purpose input	Closed	X5	Stops motion in CCW direction, CCW limit warning ON
		Open	X5	Rotates in CCW direction as normal
20	X5 sets CCW limit Stops motion when X5 is open X6 as general purpose input	Open	X5	Rotates in CCW direction as normal
		Open	X5	Stops motion in CCW direction, CCW limit warning ON

Software Configuration

On the Drive Configuration page - Input& Output, select X5/X6 functions to set up

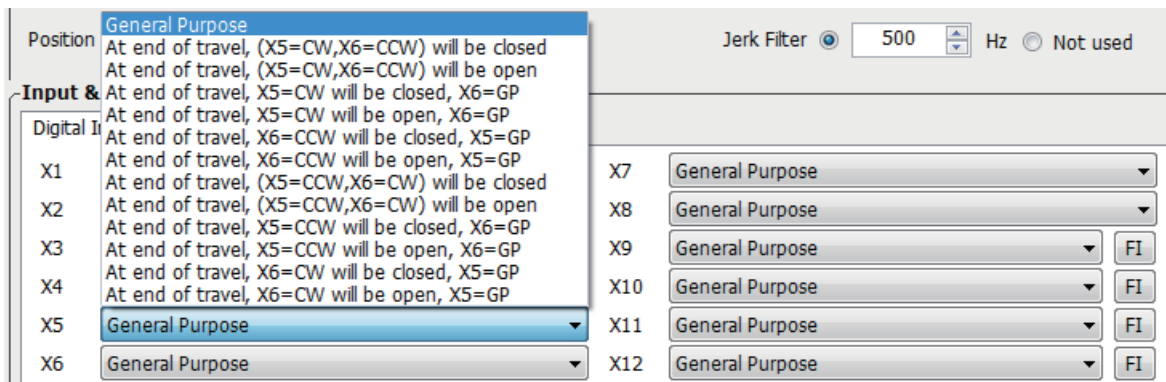

7.1.4 Global Gain Selection

Use input X7 for the Global Gain selection. This gain selection function is used to dynamically configure the servo drive to run the motor with the least time delay and as close as possible to the host command. When load characteristics change significantly, change of this gain value will reduce the motor’s settling time and motor vibration. It can be used to optimize the motor’s overall performance. The two global gain parameters are: P-00 (KP), and P-01 (KG).

In factory default mode, this function is disabled. It can be set via M Servo Suite software or P-65 (MI) first digit (from right to left) in parameter setting mode directly from the drive.

Signal Name	PIN	P-65 (MI)	Condition	Function
X7	X7+ (39) X7- (38)	□□□1	Closed	Use global gain 1-----P-00 (KP)
			Open	Use global gain 2-----P-01 (KG)
		□□□2	Closed	Use global gain 2-----P-01 (KG)
			Open	Use global gain 1-----P-01 (KP)
		□□□3 (default)		Always use global gain 1----P-00(KP)

Software Configuration

On the Drive Configuration page - Input & Output, select X7 input to set up.

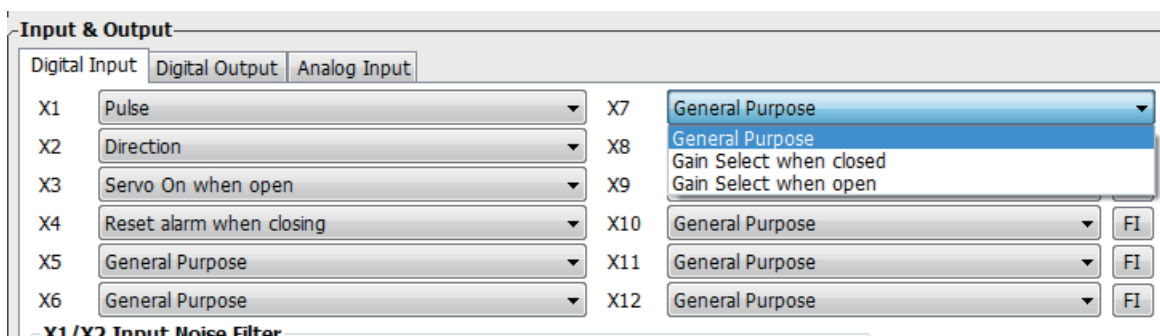

7.1.5 Control Mode Selection

M2DC series servo drives allows to the choice of 2 types of control modes to be selected by using external input X8. The control modes can be configured via two parameters P-12 (CM) and P-13 (CN).

In factory default mode, the control mode switch function is disabled. It can be configured via M Servo Suite or P-65 (MI) third digit (from right to left) in parameter setting mode on the drive's control panel.

Signal Name	PIN	P-65 (MI)	Condition	Function
X8	X8+ (12) X8- (32)	□1□□	Closed	Use Control mode 1 - P-12 (CM)
			Open	Use Control mode 2 - P-13 (CN)
		□2□□	Closed	Use Control mode 2 - P-13 (CN)
			Open	Use Control mode 1 - P-12 (CM)
		□3□□ (Default)		Always use control mode 1 - P-12 (CM)

Software Configuration

On the Drive Configuration page - Input & Output, select X8 function to set up.

The screenshot shows the 'Input & Output' configuration window. The 'Digital Input' tab is active. The X8 input is configured with 'General Purpose' selected. The dropdown menu for X8 is open, showing the following options: 'General Purpose', 'Change Control Mode when closed', and 'Change Control Mode when open'. Other inputs (X1-X7, X9-X12) are also visible, with X11 and X12 having 'FI' buttons next to them.

7.1.6 Drive On Fault Output

When faults occur, the drive will send an “On-Fault” output and it will also immediately disable the drive. Faults include: position error, encoder error, over temperature, over voltage, low voltage, internal voltage fault, STO warning, FPGA error, over current, over velocity limit, bad hall sensor. The “On-Fault” output signal can be set by P-65 (AO) on the drive’s control panel.

Signal Name	PIN	P-65 (AO)	Condition	Function
Y1	Y1+ (37) Y1- (36)	□2□□	Closed	When no warning, output is closed
			Open	When warning occurs, output is open
		□1□□ (Default)	Closed	When warning occurs, output is closed
			Open	When no warning, output is open
		□3□□		General purpose output, function disabled

Software Configuration

On the Drive Configuration page - Input & Output select Y1 output to set up.

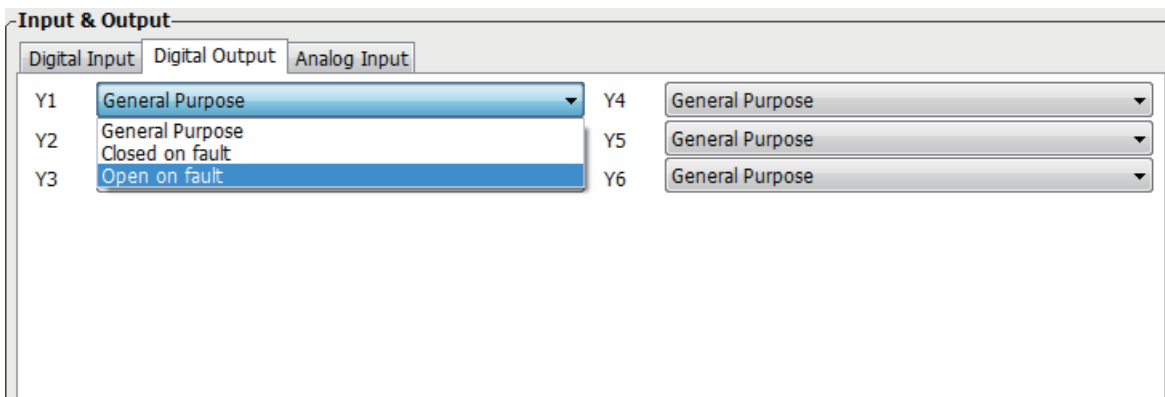

7.1.7 Motor Brake Control

A servo motor brake is only to be used for holding the load when the motor is disabled or powered OFF. It ensures the motor's rotor (and connected load) will NOT move due to gravity or any other external forces.

In order to prevent damage to the brake, there are delay sequences that are executed during the brake operation. Use caution when setting up the brake operation sequence.

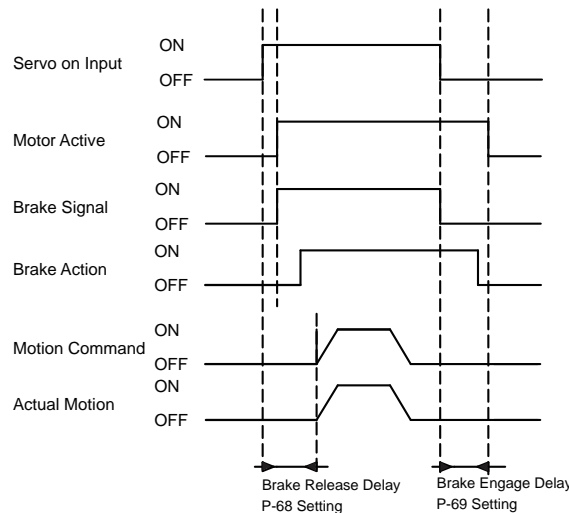

The Brake Output (BO) setting can be configured with the M Servo Suite software or with parameter P-67 (BO) as shown in the table below. Brake disengage delay and engage delay times can be configured via M servo suite software, or by changing parameters P-69 (BD) and P-70 (BE) directly on the drive.

Name	PIN	P-67(BO)	Condition	Function
Y2	Y2+ (11) Y2- (10)	2	Closed	Engage brake, brake holds the motor shaft
			Open	Release brake, brake releases the motor shaft
		1 (default)	Closed	Release brake, brake releases the motor shaft
			Open	Engage brake, brake holds the motor shaft
		3 (default)		General purpose input, output function disabled

Software Configuration

On the Drive Configuration page - Input & Output, select Y2 output to set up.

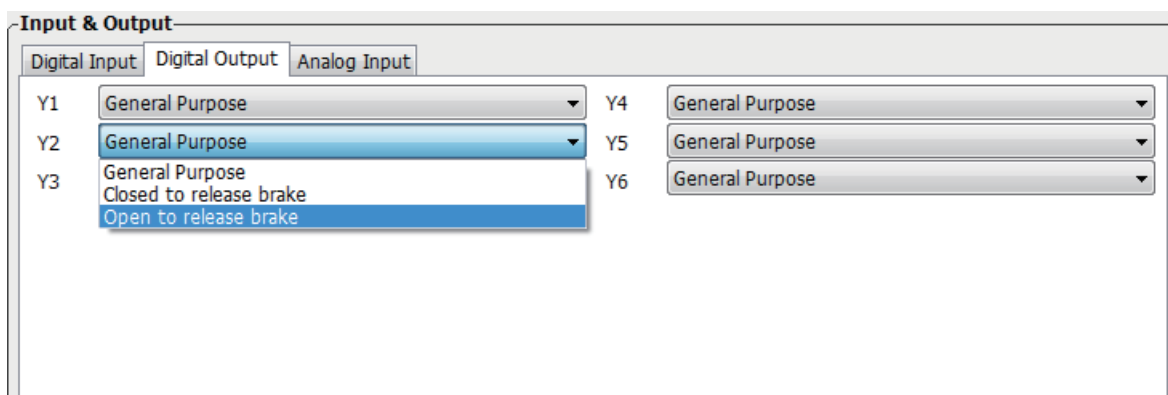

7.1.8 Servo Ready Output

When the servo drive is powered on, if no faults are present, the Y3 output can be configured output a “servo ready” signal.

This servo ready function can be configured via M Servo Suite software, or by changing parameter P-68 (MO) the first digit (from right to left) on the drive’s control panel.

Signal Name	PIN	P-68(MO)	Condition	Function
Y3	Y3 (42) OUT- (41)	□□□E	Closed	Closed when servo is not ready
			Open	Open when servo is ready
		□□□D (default)	Closed	Closed when servo is ready
			Open	Open when servo is not ready
		□□□3 (default)		General purpose, function disabled

Software Configuration

On the Drive Configuration page - Input & Output select Y5 output to set up.

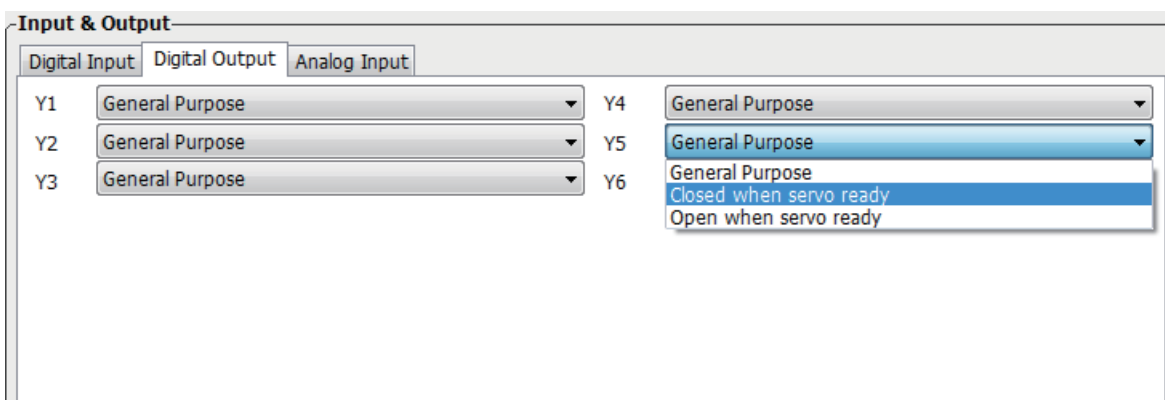

7.2 Position Mode

Position mode is widely used in applications where precise positioning is required. In M2DC series servo drives there are 3 types of position mode: digital pulse position mode, analog position mode and position table mode.

Mode	Control Signal	P-12 (CM) definitions	Description
Digital pulse position mode	Pulse & Direction CW/CCW Pulse A/B Quadrature	7	Up to 500KHz open collector input signal or up to 2MHz differential input signal
Analog position mode	+10V~-10V Analog signal	22	Use analog voltage signal for position control
Position table	Digital input signal	25	Two motion control modes: linear motion with maximum of 64 position set points, and rotary motion with maximum of 32 position division points

NOTE: Configuration setting by M servo suite is recommended.

7.2.1 Digital Pulse Position Mode Connection Diagram

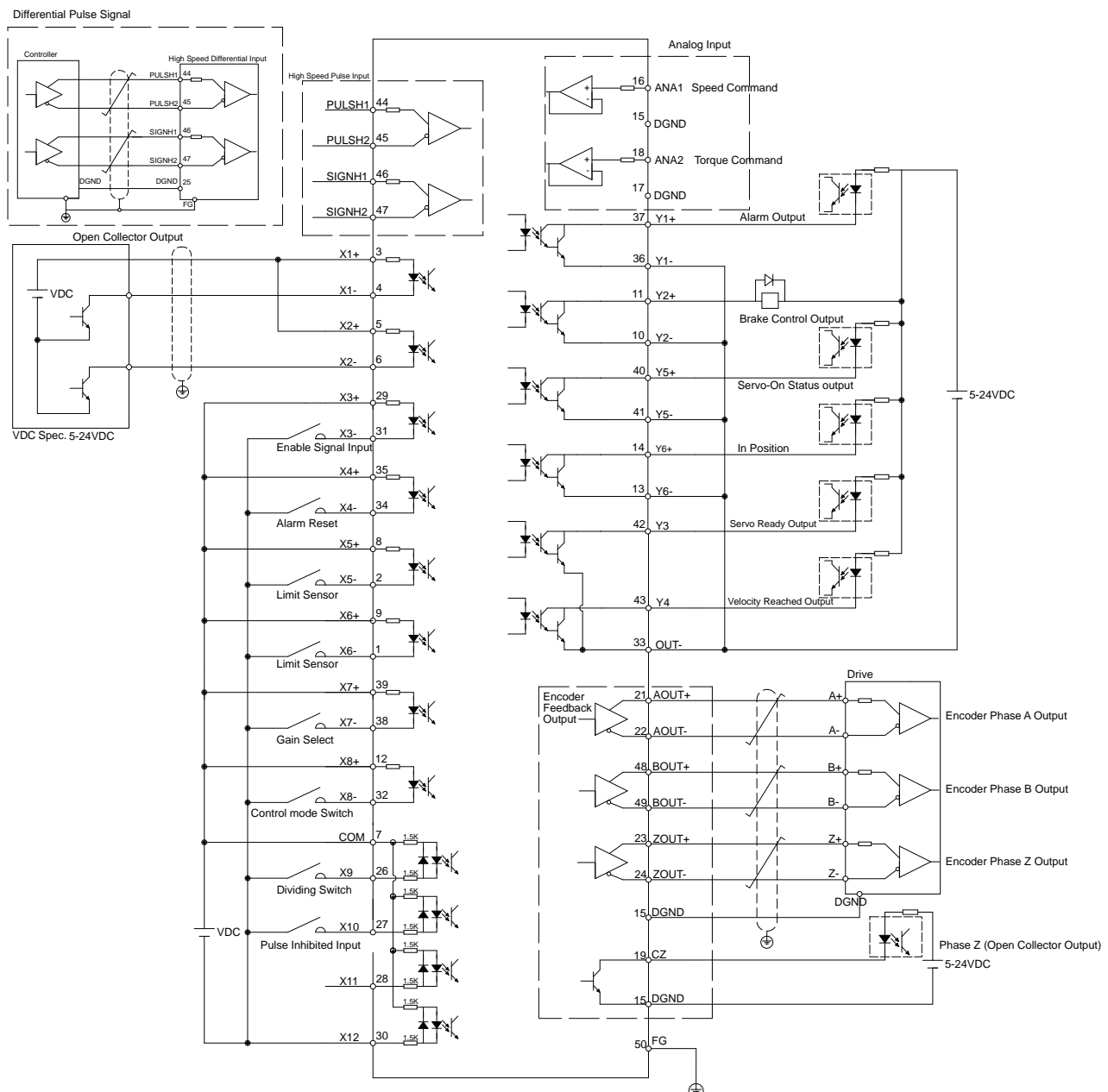

7.2.2 Input Pulse Type And Input Noise Filter

There are three types of pulse modes: STEP & Direction; CW/CCW Pulse; A/B Quadrature.

Parameter P-43 (SZ) uses decimal numbers to define pulse input type, polarity and input filter frequency. Transferred into a binary number, the HIGHER 8 bits of the number define input filter frequency, and the LOWER 8 bits define pulse input type, and polarity.

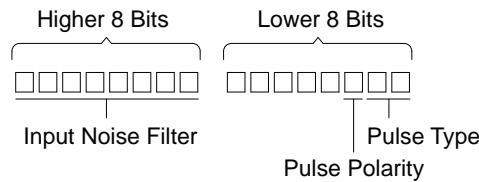

7.2.2.1 Input Pulse Type Setting

Parameter	Pulse	CW direction setting	CW	CCW	setting value (decimal)
P-43 (SZ) Lower 8 bits	Step & Direction	X2 on			0
		X2 Off			4
	CW/CCW	Pulse On X1			1
		Pulse On X2			5
	A/B Quadrature	X1 Lead X2			2
		X2 Lead X1			6

7.2.2.2 Input Noise Filter Setting

The input noise filter is a low pass filter. When the pulse input and output duty cycle is set to 50%, the P-43 (SZ) setting value are as follows

Parameter	setting value (decimal)	Filter Frequency	setting value (decimal)	Filter Frequency
P-42 (SZ) Higher 8 bits	25344	100K	4864	500K
	16640	150K	3072	750K
	12544	200K	2304	1M
	9984	250K	1792	1.2M
	8192	300K	1280	1.5M
	6144	400K	1024	2M

7.2.2.3 Parameter P-43 (SZ) Setting

Parameter P-43 (SZ)'s higher 8 digits and lower 8 digits set the definition for input filter frequency and pulse type, the setting values are as shown in table below:

Filter Frequency	pulse type	CW/CCW condition	P-43 (SZ) setting value	Filter Frequency	pulse type	CW/CCW condition	P-43 (SZ) setting value
100K	Step & Direction	X2 on	25344	500K	Step & Direction	X2 on	4864
		X2 Off	25348			X2 Off	4868
	CW/CCW	Pulse On X1	25345		CW/CCW	Pulse On X1	4865
		Pulse On X2	25349			Pulse On X2	4869
	A/B Quadrature	X1 Leads X2	25346		A/B Quadrature	X1 Leads X2	4866
		X2 Leads X1	25350			X2 Leads X1	4870
150K	Step & Direction	X2 on	16640	750K	Step & Direction	X2 on	3072
		X2 Off	16644			X2 Off	3076
	CW/CCW	Pulse On X1	16641		CW/CCW	Pulse On X1	3073
		Pulse On X2	16645			Pulse On X2	3077
	A/B Quadrature	X1 Leads X2	16642		A/B Quadrature	X1 Leads X2	3074
		X2 Leads X1	16646			X2 Leads X1	3078
200	Step & Direction	X2 on	12544	1M	Step & Direction	X2 on	2304
		X2 Off	12548			X2 Off	2308
	CW/CCW	Pulse On X1	12545		CW/CCW	Pulse On X1	2305
		Pulse On X2	12549			Pulse On X2	2309
	A/B Quadrature	X1 Leads X2	12546		A/B Quadrature	X1 Leads X2	2306
		X2 Leads X1	12550			X2 Leads X1	2310
250K	Step & Direction	X2 on	9984	1.2M	Step & Direction	X2 on	1792
		X2 Off	9988			X2 Off	1796
	CW/CCW	Pulse On X1	9985		CW/CCW	Pulse On X1	1793
		Pulse On X2	9989			Pulse On X2	1797
	A/B Quadrature	X1 Leads X2	9986		A/B Quadrature	X1 Leads X2	1794
		X2 Leads X1	9990			X2 Leads X1	1798
300K	Step & Direction	X2 on	8192	1.5M	Step & Direction	X2 on	1280
		X2 Off	8196			X2 Off	1284
	CW/CCW	Pulse On X1	8193		CW/CCW	Pulse On X1	1281
		Pulse On X2	8197			Pulse On X2	1285
	A/B Quadrature	X1 Leads X2	8194		A/B Quadrature	X1 Leads X2	1282
		X2 Leads X1	8198			X2 Leads X1	1286
400K	Step & Direction	X2 on	6144	2.0M	Step & Direction	X2 on	1024
		X2 Off	6148			X2 Off	1028
	CW/CCW	Pulse On X1	6145		CW/CCW	Pulse On X1	1025
		Pulse On X2	6149			Pulse On X2	1029
	A/B Quadrature	X1 Leads X2	6146		A/B Quadrature	X1 Leads X2	1026
		X2 Leads X1	6150			X2 Leads X1	1030

Software Configuration

On the Motor Configuration page - Control Mode Settings select pulse input type and input filter type.

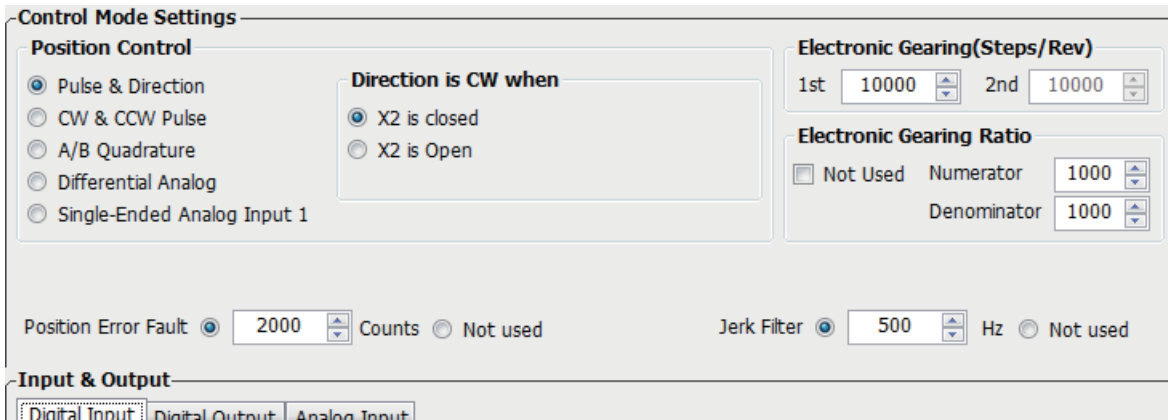

7.2.3 Control Pulse Dividing Switch

Input X9 is used as the control pulse dividing switch function. When this function is on, it will allow the drive to change the number to encoder counts per motor revolution. The first pulse dividing ratio is set via parameter P-39 (EG), the second pulse dividing ratio is set via P-40 (PV). The second digit of P-65 (MI) (right to left) is used to set switching conditions.

In factory default mode, pulse dividing switch is disabled. It can be set by M Servo Suite or parameter P-65 (MI) directly from the drive’s control panel.

Signal Name	PIN	P-65 (MI)	Condition	Function
X9	X9 (26)	□□1□	Closed	Use 1st pulse dividing ratio ----- P-39 (EG)
			Open	Use 2nd pulse dividing ratio ----- P-40 (PV)
		□□2□	Closed	Use 2nd pulse dividing ratio ----- P-40 (PV)
			Open	Use 1st pulse dividing ratio ----- P-39 (EG)
	□□3□ (default)		Always use 1st pulse dividing ratio ----P-39 (EG)	

NOTE: ONLY set the pulse dividing ratio function, when no pulse command is being sent into the drive, i.e. the motor is NOT moving.

Software Configuration

On the Drive Configuration page - Input & Output select X9 input to set up.

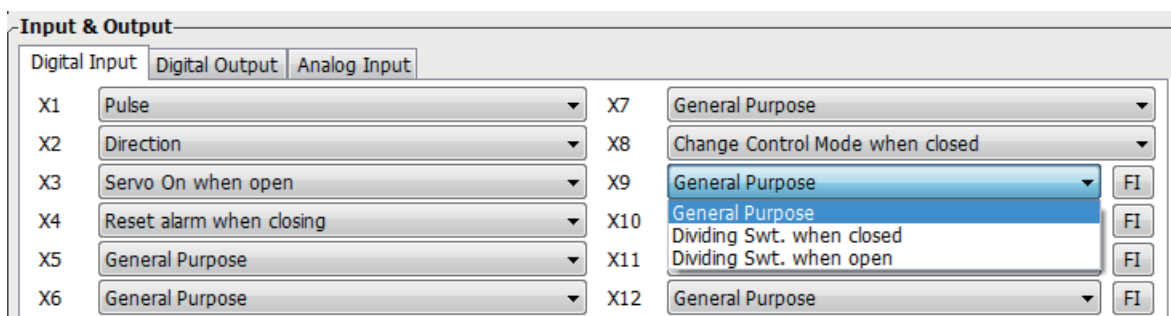

7.2.4 Pulse Inhibit

The Pulse Inhibit function uses external input X10 in digital pulse position mode. When external input X10 is triggered, it will force the drive to stop receiving pulse input from any source, and stop the servo motor immediately.

In factory default mode, this function is disabled. It can be set via M Servo Suite or P-65 (MI) directly from the drive.

Signal Name	PIN	P-65 (MI)	Condition	Function	
X10	X10 (27)	2□□□	Closed	Allow input pulse	
			Open	Disallow input pulse	
		1□□□	Closed	Disallow input pulse	
			Open	Allow input pulse	
		3□□□ (default)			General purpose input, function disabled

Software Configuration

On the Drive Configuration page - Input & Output select X10 input to set up.

The screenshot shows the 'Input & Output' configuration window. The 'Digital Input' tab is selected. The configuration for X10 is as follows:

Signal	Function	FI
X1	Pulse	
X2	Direction	
X3	Servo On when open	
X4	Reset alarm when closing	
X5	General Purpose	
X6	General Purpose	
X7	General Purpose	
X8	Change Control Mode when closed	
X9	General Purpose	FI
X10	General Purpose	FI
X11	General Purpose	FI
X12	Pulse Inhibited when closed	FI
X12	Pulse Inhibited when open	FI

7.2.5 Electronic Gearing Ratio

The host command pulse count per revolution times the electronic gearing ratio set on the drive will result in the actual number of pulses per revolution at the motor shaft. This feature allows more freedom and set up flexibility when a certain pulse count or moving counter is required

If the step pulse per revolution is 10000 pulse/rev and the electronic gearing ratio is set to 1, when the host sends 10000 pulses, the motor will turn 1 revolution. If the electronic gearing ratio is set to 1/2, then motor will move only 1 pulse position for every 2 pulses the drive receives from the host, i.e. 20000 pulses for 1 motor revolution. In some cases, reasonable electronic gearing ratio can simplify the calculation for the host when sending pulse commands.

Linear Actuator Example

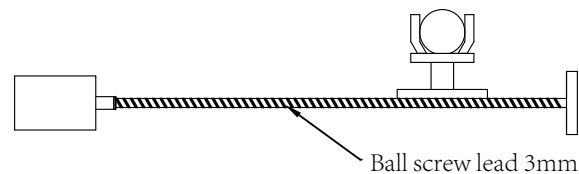

Distance for screw lead move requirement is 4mm.

(con't. on next page)

If no electronic gearing is used, the following pulse count example shows the dilemma:

Because the screw lead is 3mm, (i.e. when the motor rotates 1 rev, the load moves 3mm), when a move distance of 4mm is required, it is 4/3 of rev.

Pulse Count Requirement

If 1 motor rev requires 10000 pulses, then $10000 \times \frac{4}{3} = 13333.33333 \dots$ pulses

This leads to infinitely repeating number with a cumulative error in pulse counter.

If using an electronic gearing ratio:

If 1 pulse is set to 1um, and 10000 pulse per rev, the Electronic gearing ratio can be set as follows:

$$\frac{3000}{10000} \times \frac{a}{b} = 1um$$

If Electronic gearing ratio is set to $\frac{a}{b} = \frac{10}{3}$, then 1 pulse send by the host, will leads to 1um movment at the load.

Parameter Settings

Parameter	Name	Data Range	Default	
P-39 (EG)	Required pulse per rev	200~51200	10000	Set Required pulse per rev
P-40 (PV)	Secondary Required pulse per rev	200~51200	10000	Set secondary Required pulse per rev
P-41 (EN)	Electronic gearing Ratio Numerator	1~1000	1000	Set Electronic gearing Ratio Numerator
P-42 (EU)	Electronic gearing Ratio Denominator	1~1000	1000	Set Electronic gearing Ratio Denominator

7.2.6 Jerk Smoothing Filter

Applying this dynamic filter on speed and direction signals can significantly smoothing motor rotary motion, and reduce wear on mechanical system components.

JerK smoothing filter effects are as follows:

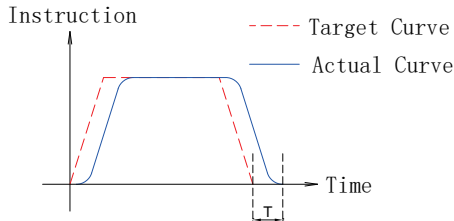

- 1) The smaller the value of P-07 (KJ), the stronger the effect will be.
- 2) Jerk smoothing filter will cause command delay time T, but it will not effect position accuracy.

Parameter Settings

Parameter	Name	Data Range	Default	
P-07 (KJ)	JerK Filter Frequency	0~5000	5000	Set jerK smoothing filter parameter

NOTE: When set to 0, there will be no filter effect.

7.2.7 In-Position Error Output

In position mode, using the “In-Position Error” output function can help the user the define motor’s in-position status. When the difference between the drive’s total pulses received and the motor’s actual rotating pulse count is within the in-position error range, the drive will send out a motor in-position signal.

The forth digit of parameter P-68 (MO) defines Y6 output function; parameter P-46 (PD) defines the in-position error range. P-47 (PE) defines in-position error time duration. If the in-position error is within the P-46 (PD) range for more than the time duration of P-47 (PE) setting, the drive will output the motor in-position signal.

Signal Name	PIN	P-68 (MO)	Condition	Function
Y6	Y6+ (14) Y6- (13)	5□□□	Closed	Closed means motor is not in position
			Open	Open means motor is in position
		4□□□ (default)	Closed	Close means motor is in position
			Open	Open means motor is not in position
		3□□□		General purpose output, function disabled

Parameter Settings

Parameter	Name	Data Range	Default	
P-46 (PD)	In-position error range	0~32000	10	This parameter sets the in-position error range, when in-position error count is less than the range, drive will indicate the motor is in position.
P-47 (PE)	In-position duration count	0~32000	10	If the position error is within the in-position range and lasts longer than the duration time, the motion is considered to be complete and the motor is in position. If the time value is set to 100 the position error must remain in the range for 100 processor cycles before the motion is considered to be complete. One processor cycle is 250μsec.

7.2.8 Gain Parameters For Position Control Mode

In position mode, proper gain parameters will cause the servo system to run and stop more smoothly, and accurately, thereby optimizing its performance.

In most cases, M Servo Suite's auto tuning function will help to automatically tune these parameters. However, in some cases, the fine tuning function from the software or parameter setting mode on the drive may be needed to optimize performance.

Parameter	Name	Data Range	Default
P-00(KP)	Global gain 1	0~32767	10000
P-01(KG)	Global gain 2	0~32767	12000
P-02(KF)	Proportional Gain	0~32767	10000
P-03(KD)	Derivational Gain	0~32767	3000
P-04(KV)	Damping Gain	0~32767	10000
P-05(KI)	Integrator gain	0~32767	500
P-06(KK)	Inertia Feedforward Constant	0~32767	800
P-07(KJ)	Jerk Filter Frequency	0~32767	5000
P-10(KE)	Deriv Filter factor	0~32767	15000
P-11(KC)	PID Filter factor	0~32767	25000

7.2.9 Software Configuration For Position Mode

The M Servo Suite can help easily configure the drive and motor, and optimize the tuning parameters.

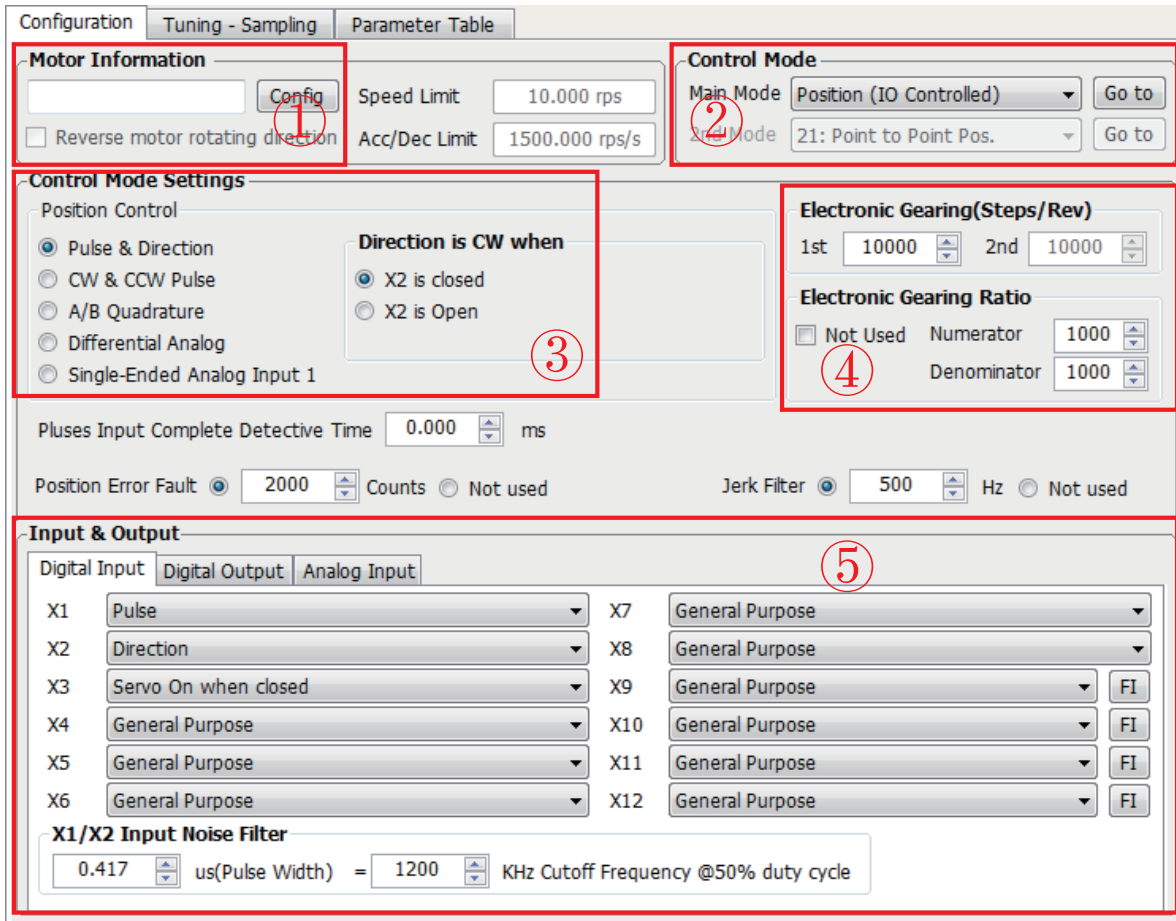

Step	Operation	Description
Step 1	Configure motor	Choose your motor model. Refer to Section 2.3 for motor details.
Step 2	Choose control mode	In Control Mode, choose “Position” for Position Mode.
Step 3	Control mode configuration	Choose specified input pulse type. Refer to Section 4.8 for CN2 input signal connections, and Section 7.2 for position mode details.
Step 4	Set electronic gearing ratio	Refer to Section 7.2.5 for electronic gearing ratio settings.
Step 5	Set analog signal	Set digital input/output functions. Refer to Section 4.8 for CN2 connections, Section 7.2 for position mode, and Section 7.1 for general function settings.

7.3 Velocity Mode

The velocity control mode is used for applications that require precise velocity control. For M2DC series servo drives, there are 4 types of velocity control mode: fixed-speed mode, analog command mode, SCL control mode and multi-velocity control mode. Fixed-speed mode will set the motor running at a constant speed. For analog command mode, velocity is controlled by external voltage input. SCL is a unique software command tool of MOONS'. For multi-velocity control mode, the drive uses external inputs to set up different velocity values. There are up to 8 different velocity values that can be set.

Mode	Control Signal	P-12 (CM) Definitions	Description
Analog velocity mode	+10~-10V Analog signal	11	Analog velocity mode, NO run/stop signal, X2 is direction switch.
Analog velocity mode	+10~-10V Analog signal	12	Analog velocity mode, X1 is run/stop signal, X2 is direction switch.
Velocity Mode	Digital input signal	15	Profile velocity mode, after drive is enabled. The drive will run at velocity set by P-22 (JS). NO run/stop signal, X2 is direction switch
Velocity Mode	Digital input signal	16	Profile velocity mode, after drive is enabled. The drive will run at velocity set by P-22 (JS). X1 is run/stop switch, X2 is direction switch
In-position error output	Digital output signal	17	Profile velocity mode, NO run/stop signal. X2 is direction switch. X10, X11, X12 are speed selection switches.
In-position error output	Digital output signal	18	Profile velocity mode, X1 is run/stop switch. X2 is direction switch. X10, X11, X12 are speed selection switches.

NOTE: We highly recommend using M Servo Suite software to configure velocity mode.

7.3.1 Velocity Mode Connection Diagram

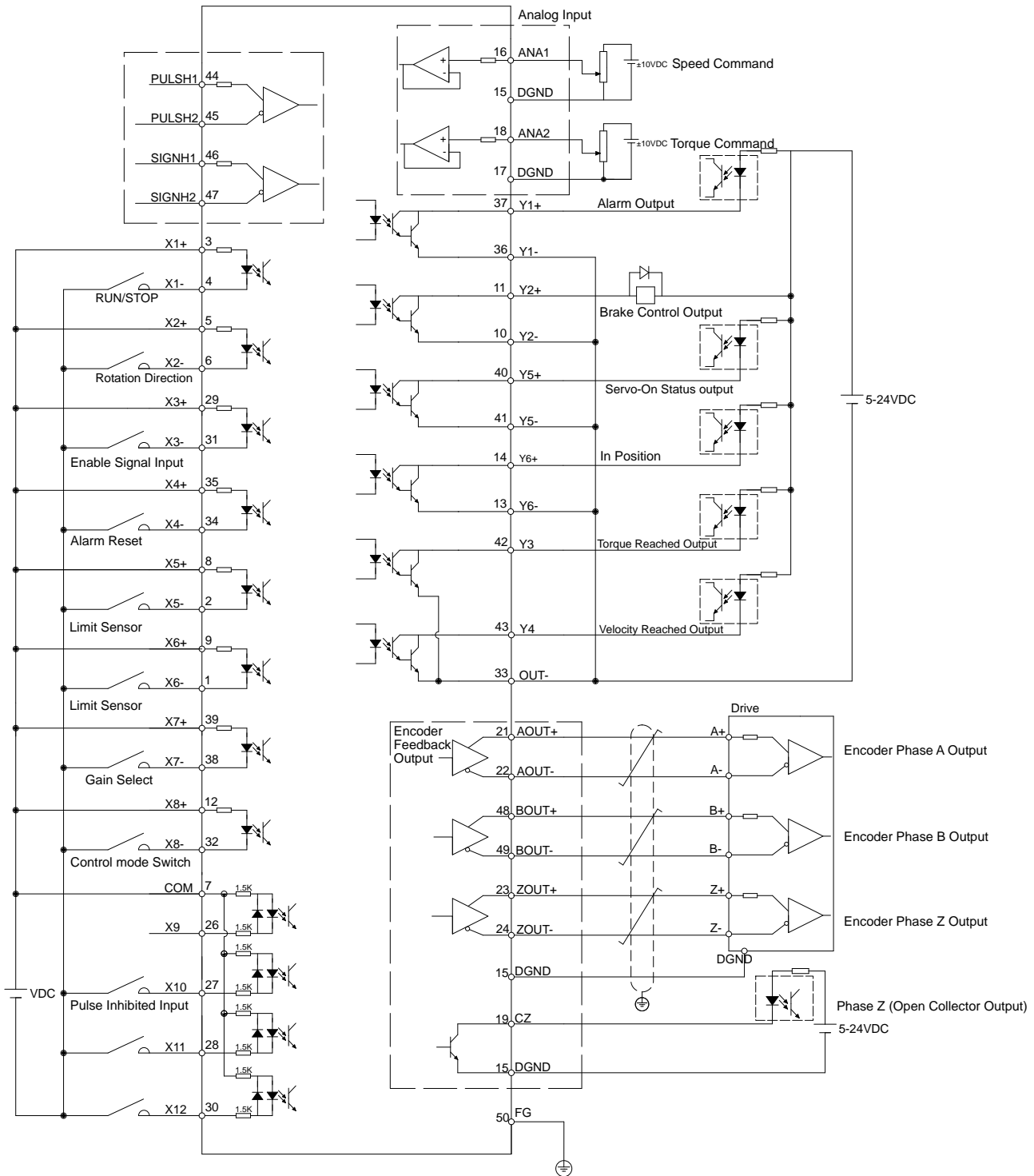

7.3.2 Parameter Settings For Analog Velocity Control Mode

The M2DC series servo drive has 2 12-bit analog A/D converters. When a single-ended input signal is used, analog input 1 (ANA1) is used for the velocity command, and analog input 2 (ANA2) is used for the torque limit setting. Differential input via ANA1/ANA2 is also available. In addition, a low pass filter, analog offsets and deadband values can be set to the drive.

Parameter	Name	Data Range	Default	Unit	Description
P-12 (CM)	Main control mode	1~8,11,12 15~18,21,22,25	7		Drive's main control mode selection
P-13 (CN)	Secondary control mode	1~8,11,12 15~18,21,22,25	21		Drive's secondary control mode selection
P-15(JM)	Jog Mode	1~2	2		Choose velocity control mode
P-50 (AG)	Analog Velocity Gain	-100~100	20	Rps	Motor rotating velocity when analog voltage is 10VDC
P-51 (AN)	Analog Torque Gain	-20~20	1	A	Motor rotating torque when analog voltage is 10VDC
P-52 (AV1)	Analog voltage offset 1	-10~10	0	V	Set analog voltage input 1 offset value
P-53 (AV2)	Analog voltage offset 2	-10~10	0	V	Set analog voltage input 2 offset value
P-54 (AV3)	Analog voltage offset (differential)	-10~10	0	V	Set differential analog voltage input offset value
P-55 (AS)	Analog input type	0~1	0		Analog input type
P-56 (AD1)	Analog deadband 1	0~255	0	mV	Set analog input 1 deadband offset value
P-57 (AD2)	Analog deadband 2	0~255	0	mV	Set analog input 2 deadband offset value
P-58 (AD3)	Analog deadband (differential)	0~255	0	mV	Set analog differential input deadband offset value
P-59 (AF)	Analog input low pass filter	1~15990	500		Analog input noise filter
P-60 (AT)	Analog trigger point	-10~10	0.000	V	
P-61 (FA1)	Define Analog input 1 function	1,3	<input type="checkbox"/> 3		Define Analog input 1 function
P-61 (FA2)	Define Analog input 2 function	2,3	3 <input type="checkbox"/>		Define Analog input 2 function

NOTE: The units shown in the table above might be different from the LED display units on the drive. Please refer to Chapter 8 for details.

7.3.3 Basic Settings For Analog Velocity Control Mode

7.3.3.1 Command Signal For Analog Velocity Mode

In Analog input velocity mode, both single-ended and differential connection types are acceptable.

Single Ended Analog Input

PIN type	Signal	PIN number	Function
Input	ANA1	16	Analog velocity input signal
	DGND	15	Analog velocity input signal reference (digital ground)

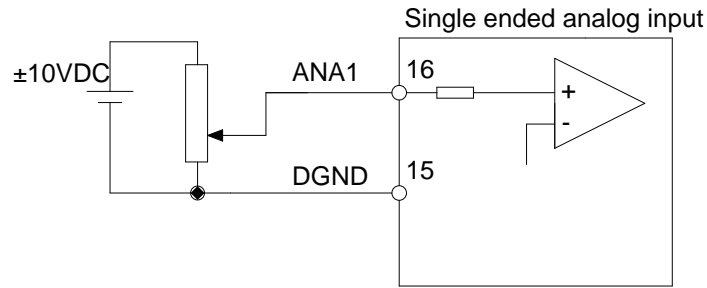

Differential Analog Input

PIN type	Signal	PIN number	Function
Input	ANA1	16	Analog velocity input for differential input signal
	ANA2	18	
	DGND	15	Analog velocity input signal grounding (digital ground)

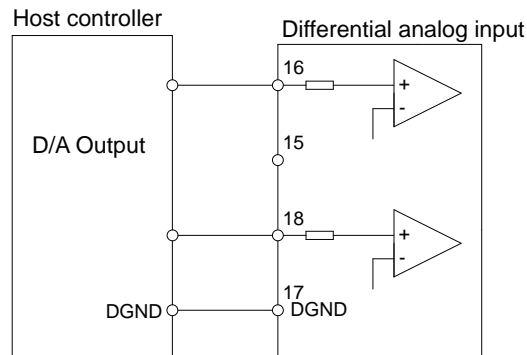

7.3.3.2 Analog Velocity Gain

Analog input voltage range is between -10V~+10V. In analog velocity, setting the velocity value and correspondent input voltage value is required. This can be set via M Servo Suite software or P-50 (AG) on the drive's control panel.

Parameter	Name	Data Range	Default	Unit	Description
P-50 (AG)	Analog Velocity Gain	-100~100	20	rps	The corresponding motor rotary velocity for 10vdc analog input voltage.

NOTE: When viewing or setting the velocity value on the drive's control panel, please refer to the following calculation:

$$\text{Drive display value} = \underline{V} \times 240$$

V is target setting velocity rev/second (rps)

Setting Via Software

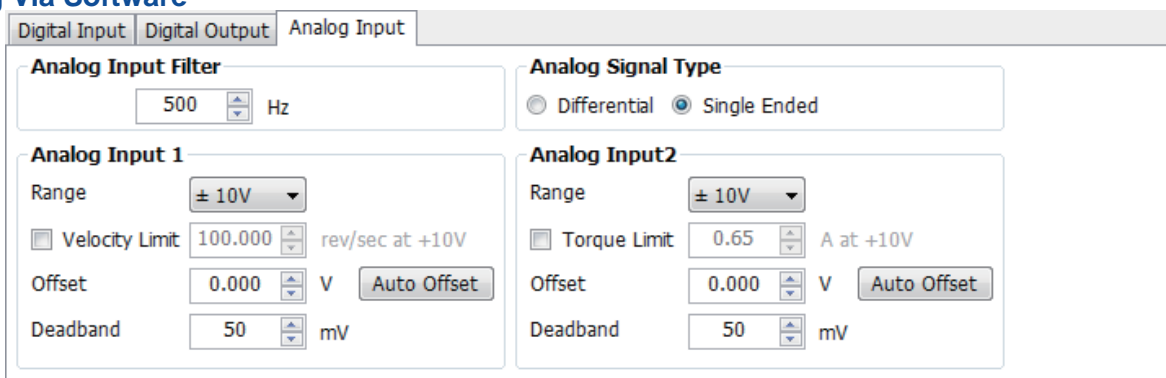

7.3.3.3 Analog Input Voltage Offset

In some cases, even when the host controller sets the analog command to 0V, the servo motor might still rotate slowly. This is caused by a voltage bias from the analog voltage supply. M Servo Suite can automatically offset the analog voltage bias, or users can manually adjust the tuning voltage offset value by changing parameters P-52 (AV1) and P-53 (AV2).

Parameter	Name	Data Range	Default	Unit	Description
P-52 (AV1)	Analog input 1 offset	-10 - 10	0	V	Set Analog input 1 offset
P-53(AV2)	Analog input 2 offset	-10 - 10	0	V	Set Analog input 2 offset
P-54(AV3)	Differential Analog offset	-10 - 10	0	V	Set differential analog input offset

NOTE: When viewing or setting this value on the drive's control panel, refer to following calculation:

$$\text{Drive display value} = \underline{A} \times 2730$$

A is target setting offset, unit Voltage (V)

Setting Via Software

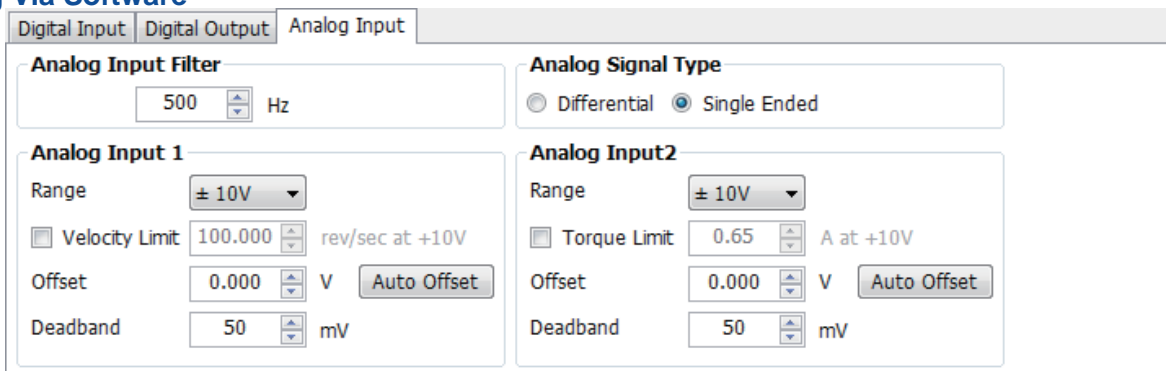

7.3.3.4 Analog Input Deadband

In analog control model, even when the input voltage is 0V, it is almost impossible to ensure that the input voltage is absolute 0V due to external interferences. In some cases, it might cause the motor to turn slowly in either direction. Therefore, it is recommended that a reasonable deadband value be set to prevent this issue.

The analog input deadband can be configured via M Servo Suite or parameter P-56 (AD1) directly from the drive's control panel.

Parameter	Name	Data Range	Default	Unit	Description
P-56 (AD1)	Deadband for analog input 1	0~255	0	mV	Set deadband for analog input 1
P-56 (AD3)	Differential analog Deadband	0~255	0	mV	Set deadband for differential analog input

Setting Via Software

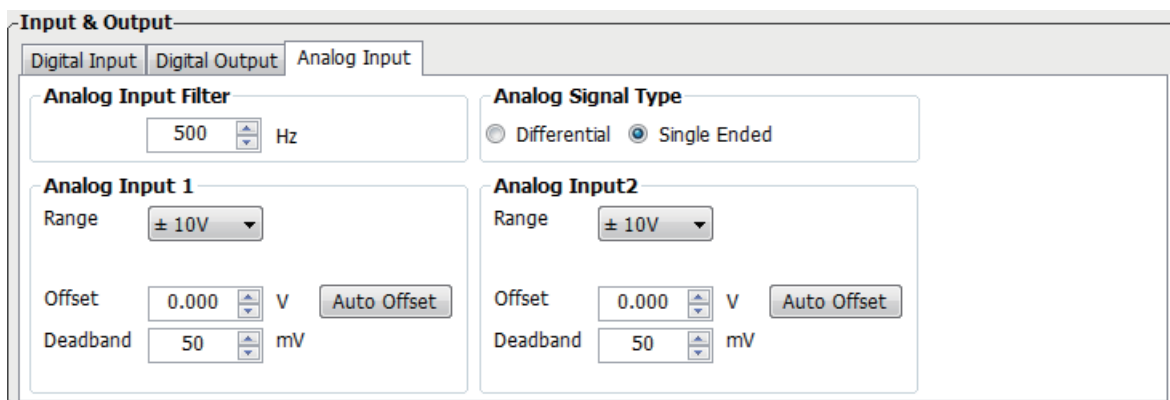

7.3.3.5 Run/Stop And Direction Signal

In analog velocity mode, external input X1 can set as the run/stop switch and X2 can set as the direction switch.

Signal Name	PIN	Signa	Function	Description
X1	X1+ (3)	Closed	Velocity mode run/stop switch	Motor running, analog voltage value defines rotary velocity.
	X1- (4)	Open		When switch is open, Motor stops rotation regardless of analog input voltage.
X2	X2+ (5)	Closed	Velocity mode run/stop switch	Change motor rotation direction.
	X2+ (5)	Open		Not in use.

Setting Via Software

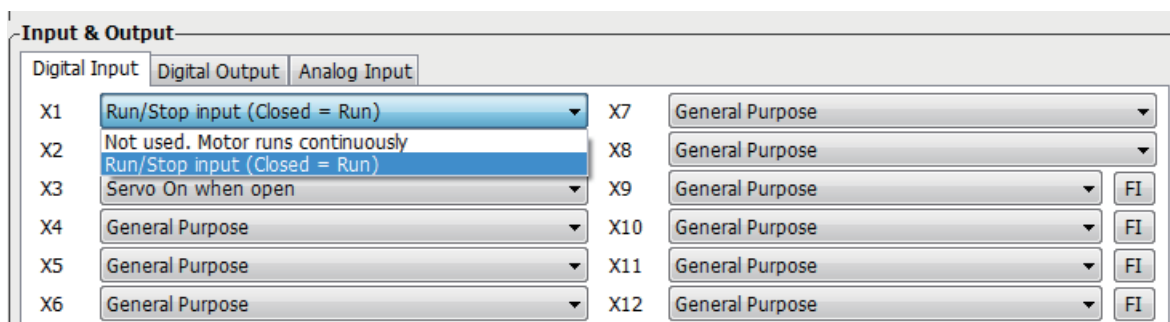

7.3.3.6 Torque Limit

In single-ended analog mode, analog input 2 (ANA2) can be used to set motor's output torque.

Parameter Settings

Parameter	Name	Data Range	Default value	Unit	Description
P-55 (AS)	Analog type	0~1	0		Analog input type 0: Single ended input 1: Differential input
P-62 (FA2)	Analog 2 function setting	2~3	3□		Analog input port 2 function setting: 2: Torque limit setting 3: Not in use
P-51 (AN)	Analog Torque Gain	Based on drive's output ability	1	A	Sets corresponding torque output value against 10VDC input voltage.

NOTE: When viewing or setting this value on the drive's control panel (P-51 (AN)), refer to the following calculation:

$$\text{Drive display value} = \underline{A} \times 100$$

where \underline{A} is target torque output value

Setting Via Software

Input & Output

Digital Input | Digital Output | **Analog Input**

Analog Input Filter

500 Hz

Analog Signal Type

Differential Single Ended

Analog Input 1

Range: ± 10V

Speed: 100.000 rps at +10V

Offset: 0.000 V Auto Offset

Deadband: 50 mV

Analog Input2

Range: ± 10V

Current: 1.50 Amps at +10V

Offset: 0.000 V Auto Offset

Deadband: 50 mV

7.3.3.7 Target Velocity Reached

In velocity mode, when the motor's actual velocity and commanded target velocity are the same, the "velocity reached" output signal can be sent by output Y4 .

The second digit (from right to left) of parameter P-68 (MO) defines the output signal Y4.

Signal Name	PIN	P-68 (MO)	Condition	Function
Y4	Y4 (43) OUT- (33)	□□B□	Closed	Closed means target speed not reached
			Open	Open means reach output speed
		□□A□	Closed	Close means reach output speed
			Open	Open means target speed not reached
	□□3□ (default)		General purpose signal, function disabled.	

Parameter Settings

Parameter	Name	Data Range	Default value	Unit	Description
P-85 (VR)	Ripple range setting for velocity reached	0~136	0.000	Rps	The accepted velocity ripple value around the targeted velocity. If the difference between the actual velocity and the targeted velocity is within the ripple value, the drive will then report that the actual velocity meets the target velocity value.

NOTE: When viewing or setting this value on the drive's control panel, refer to following calculation:

$$\text{Velocity ripple range} = \text{LED display value} \times 240$$

Unit for **Velocity ripple range** is revolutions per second (rps)

Setting Via Software

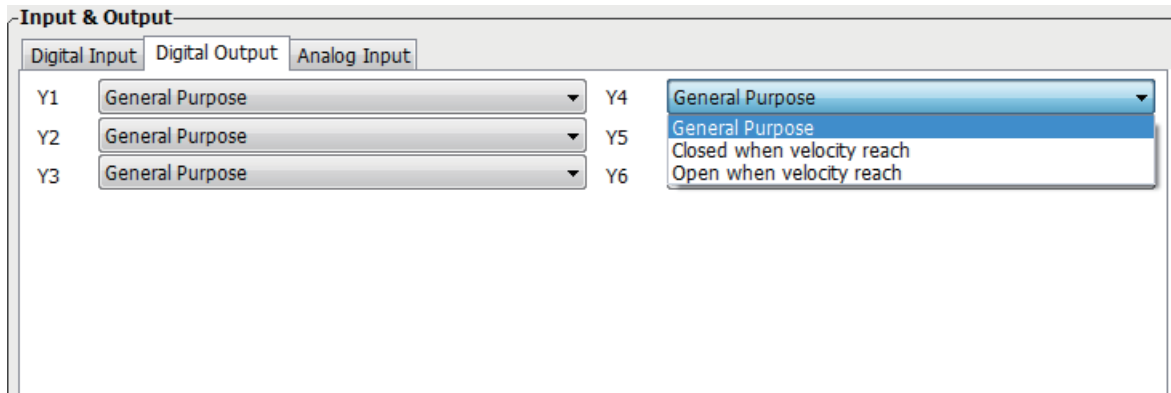

7.3.4 Analog Input Filter

When the analog input is used, there can be external signal interference that will affect the accuracy of the analog input voltage. In some cases will cause the motor to turn unexpectedly, or cause unstable torque output. Therefore, use of the analog input filter is recommended. The filter is designed as a digital low pass filter; a proper filter frequency setting can significantly improve the motor's performance.

When viewing or setting this value on the drive's control panel, refer to the following calculation:

$$\text{Display analog input value} = \frac{72090}{\frac{1400}{X} + 2.2}$$

Where X is input filter frequency, unit Hz

Setting Via Software

On the Drive Configuration page - Input & Output, Analog Inputs 1 & 2 to set up.

Input & Output

Digital Input | Digital Output | **Analog Input**

Analog Input Filter
500 Hz

Analog Signal Type
 Differential Single Ended

Analog Input 1
Range: ± 10V
Speed: 100.000 rps at +10V
Offset: 0.000 V
Deadband: 50 mV

Analog Input2
Range: ± 10V
Current: 1.50 Amps at +10V
Offset: 0.000 V
Deadband: 50 mV

7.3.5 Software Configuration for Analog Velocity Mode

The M Servo Suite software easily configures the drive and motor, and optimizes the tuning parameters.

The screenshot shows the software configuration interface for the M Servo Suite. It is divided into four main sections, each highlighted with a red box and a circled number indicating a step in the configuration process:

- Step 1:** Motor Information section, highlighting the 'Config' button next to the motor model 'SM0601AE2...'.
- Step 2:** Control Mode section, highlighting the 'Go to' button for the 'Main Mode' set to 'Velocity (IO Controlled)'.
- Step 3:** Control Mode Settings section, highlighting the 'Single-Ended Analog Input 1' radio button under 'Velocity Control by'.
- Step 4:** Input & Output section, highlighting the configuration fields for 'Analog Input 1', including Range, Velocity, Offset, and Deadband.

Step	Operation	Description
Step 1	Configure motor	Choose your motor model. Refer to Section 2.3 for motor details.
Step 2	Choose control mode	In Control Mode, choose "velocity" for Velocity Mode
Step 3	Control mode configuration	Select preferred velocity analog type. Refer to Section 7.3 for analog velocity mode and Section 7.6 for command velocity mode.
Step 4	Set analog signal	Set analog input functions in Input & Output. Refer to Section 4.8.3 for CN2 connections, Section 7.3 for velocity mode, and Section 7.1 for general function settings.

7.4 Torque Mode

Torque mode is normally used for applications that require precise torque control. For M2DC series servo drives, there are 2 types of torque control mode: analog input torque mode and SCL command mode. For analog command mode, torque is controlled by external voltage input. SCL is a unique software tool from MOONS', that uses serial communication commands to control the motor.

Mode	Control Signal	P-12 (CM) Definition	Description
Analog input torque mode	+10 to -10V Analog signal	2	Analog torque mode: No run/stop signal, No direction signal
Analog input torque mode	+10 to -10V Analog signal	5	Analog torque mode: X1 for run/stop signal, No direction signal
Analog input torque mode	+10 to -10V Analog signal	3	Analog torque mode: no run/stop signal; X2 is closed, motor will change its current rotary direction.
Analog input torque mode	+10 to -10V Analog signal	4	Analog torque mode: no run/stop signal; X2 is open, motor will change its current rotary direction.
Analog input torque mode	+10 to -10V Analog signal	6	Analog torque mode: X1 for run/stop signal; X2 is open, motor will change its current rotary direction.
Analog input torque mode	+10 to -10V Analog signal	8	Analog torque mode: X1 for run/stop signal; X2 is closed, motor will change its current rotary direction.
SCL torque control mode	SCL command	1	

7.4.1 Analog Torque Mode Connection Diagram

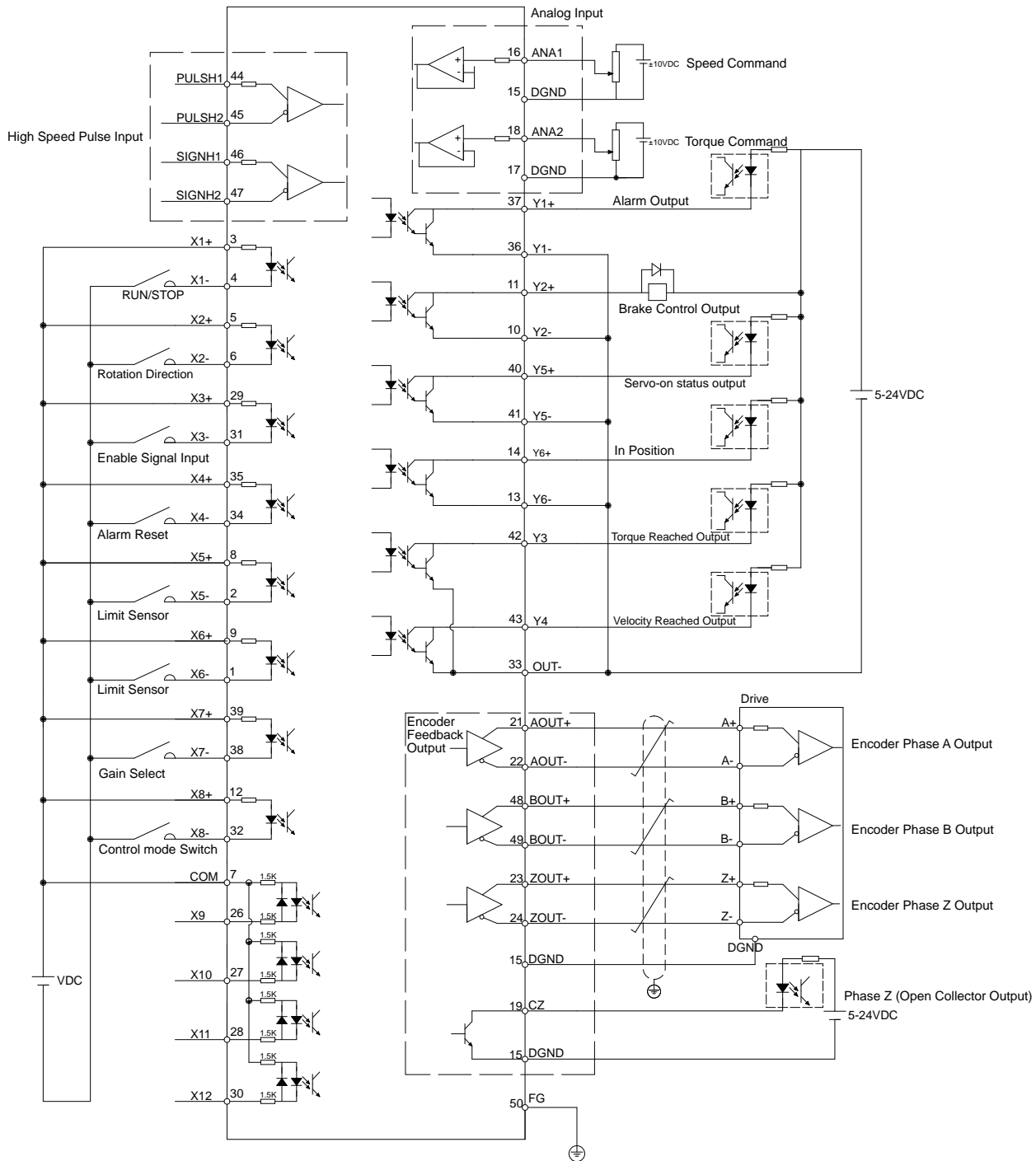

7.4.2 Parameters For Analog Torque Mode

M2DC series servo drives have 2 12-bit analog A/D converters. When single-ended input signals are used, analog input 1 (ANA1) is used for the velocity command, and analog input 2 (ANA2) is used for the rotating torque command. Differential input via ANA1/ANA2 is also available. In addition, a low pass filter, analog offsets and deadband values can be set to the drive.

Parameter	Name	Data Range	Default value	Unit	Description
P-12 (CM)	Main control mode	1~8,11,12 15~18,21,22,25	7		Drive's main control mode selection
P-13 (CN)	Secondary control mode	1~8,11,12 15~18,21,22,25	21		Drive's secondary control mode selection
P-50 (AG)	Analog velocity setting	-100 - 100	20	Rps	Motor rotating velocity when analog voltage is 10VDC
P-51 (AN)	Analog torque setting	-20 - 20	1	A	Motor rotating torque when analog voltage is 10VDC
P-52 (AV1)	Analog voltage offset 1	-10 - 10	0	V	Set analog voltage input 1 offset value
P-53 (AV2)	Analog voltage offset 2	-10 - 10	0	V	Set analog voltage input 2 offset value
P-54 (AV3)	Analog voltage offset (differential)	-10 - 10	0	V	Set analog differential voltage input offset value
P-55 (AS)	Analog input type	0 - 1	0		Set Analog input type
P-56 (AD1)	Analog deadband 1	0 - 255	0	mV	Set analog deadband offset 1 value
P-57 (AD2)	Analog deadband 2	0 - 255	0	mV	Set analog deadband offset 2 value
P-58 (AD3)	Analog deadband (differential)	0 - 255	0	mV	Set analog differential deadband offset value
P-59 (AF)	Analog input low pass filter	1 - 15990	500		Analog input noise filter
P-60 (AT)	Analog trigger point	-10 - 10	0	V	
P-61 (FA1)	Define Analog value 1	1 , 3	□3		Set Analog input 1 function
P-61 (FA2)	Define Analog value 2	2 , 3	3□		Set Analog input 2 function

NOTE: This units shown in the table above might be different from the LED display units on the drive. Please refer to Chapter 9 for details.

7.4.3 Basic Settings For Analog Torque Mode

7.4.3.1 Command Signal For Analog Torque Mode

In Analog input torque mode, both single ended and differential signal are acceptable.

Single Ended Analog Input

Pin Type	Signal Name	Connector pin allocation	Function
Input	ANA2	18	Analog torque input signal
	DGND	17	Analog torque input signal grounding

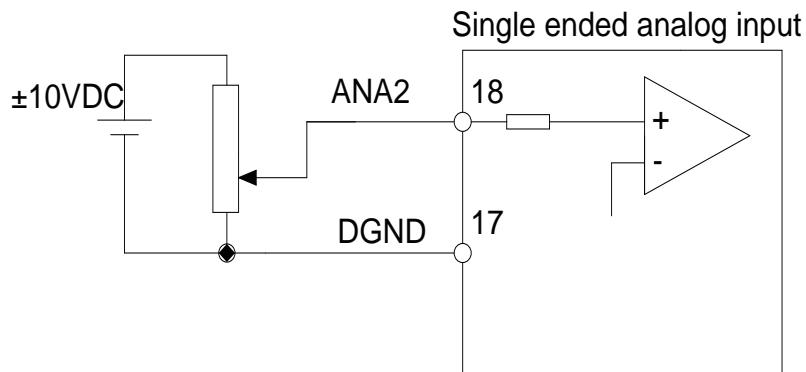

Differential Analog Input

Pin Type	Signal Name	Connector pin	Function
Input	ANA1	16	Analog torque input for differential input signal
	ANA2	18	
	DGND	15	Analog torque input signal grounding

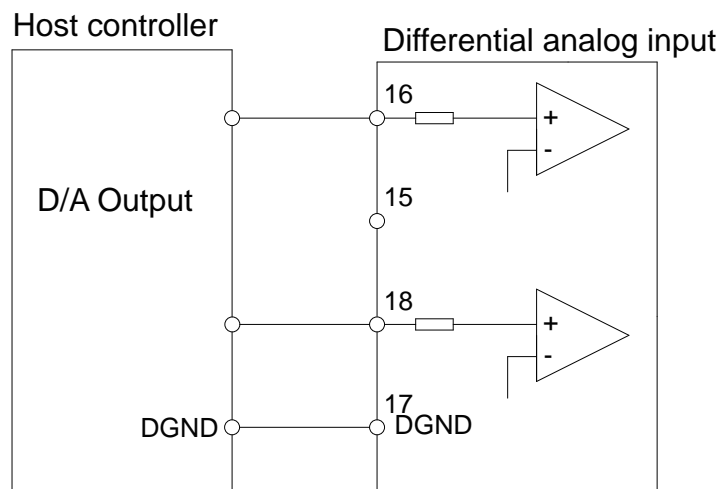

7.4.3.2 Analog Torque Gain

Analog input voltage range is -10V to +10V. In analog torque mode, the drive must be told how much current is required for a given analog input voltage. This can be configured via M Servo Suite or parameter P-51 (AN) directly from the drive's control panel.

Parameter	Name	Data Range	Default value	Unit	Description
P-51 (AN)	Analog Torque Gain	-20 - 20	depends on current motor	A	Set the analog torque value corresponding to 10VDC.

NOTE: If you need to view or set this value on the drive's control panel, refer to the following calculation:

$$\text{Drive display value} = a \times 100$$

Where is target torque value unit **a** amps

Setting Via Software

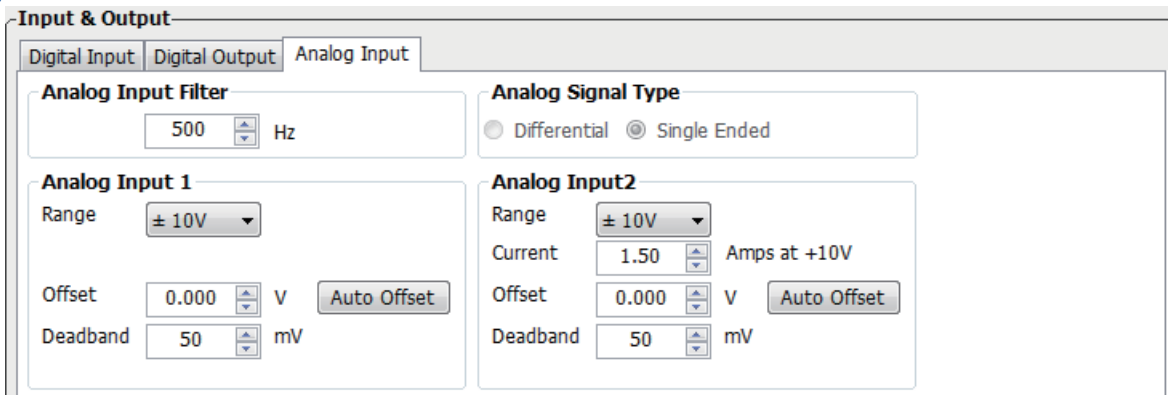

7.4.3.3 Analog Input Offset

In some cases, when a host controller has set the analog command to 0V, the servo motor might still rotate slowly. This is caused by voltage bias from the analog device. M Servo Suite can automatically offset the analog voltage bias, or it can be manually tune by changing parameter P-53 (AV2).

Parameter	Name	Data Range	Default value	Unit	Description
P-53 (AV2)	Analog input 2 offset	-10 - 10	0	V	Set Analog input 2 offset
P-54 (AV1)	Differential Analog offset	-10 - 10	0	V	Set differential analog input offset

NOTE: if you need to view or set this value on the drive's control panel, refer to the following calculation:

$$\text{Drive display value} = A \times 2730$$

Where **A** is target setting offset, unit Voltage (V)

Setting Via Software

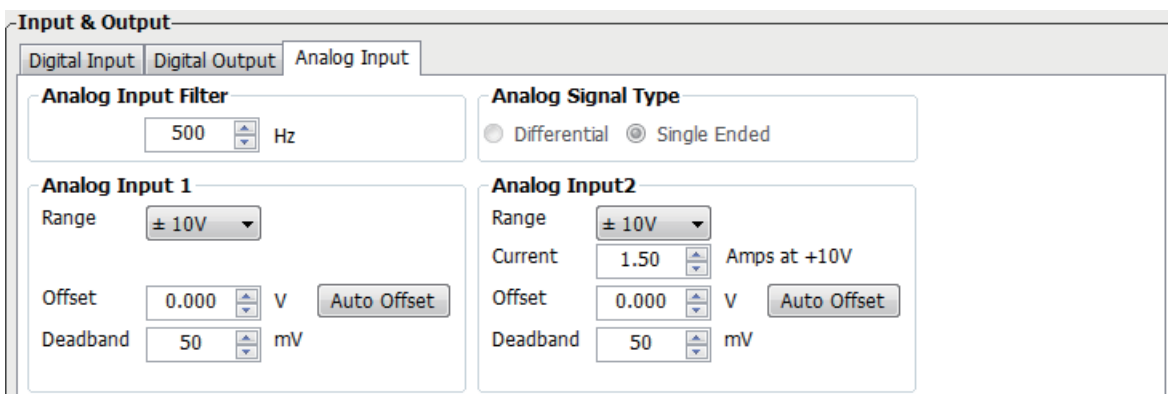

7.4.3.4 Analog Deadband

In analog control mode, even when the input voltage is 0V, it is impossible to ensure that the input voltage is absolutely zero due to external interference. In some cases, it might case motor turn slowly in either direction. Therefore, it is recommended that a reasonable deadband value be set up to prevent this issue.

It can be set by M Servo Suite or P-57 (AD2) directly from the drive's control panel.

Parameter	Name	Data Range	Default value	Unit	Description
P-57 (AD2)	Deadband for analog input 2	0 - 255	0	mV	Set deadband for analog input 2
P-58 (AD3)	Differential analog Deadband	0 - 255	0	mV	Set deadband for differential analog input

Setting Via Software

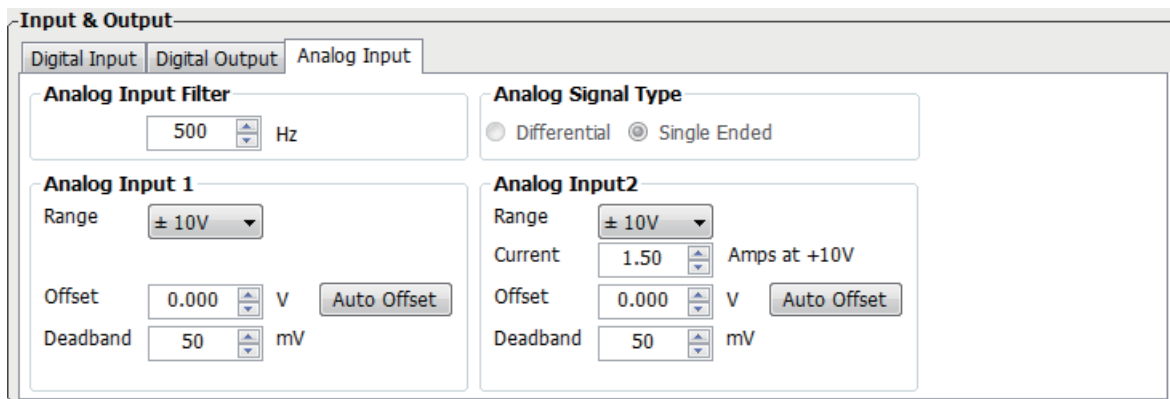

7.4.3.5 Run/Stop and Direction signal

In analog torque mode, external input X1 can set as run/stop switch, X2 can set as direction switch.

Signal Name	PIN	Condition	Function	Description
X1	X1+ (3)	Closed	Torque mode run/stop switch	When motor running, analog voltage defines motor output torque
	X1+ (4)	Open		In this mode, even with analog input, motor will not turn
X2	X2+ (5)	Closed	Torque mode direction switch	Change current motor rotary direction
	X2+ (5)	Open		Function not used

Setting Via Software

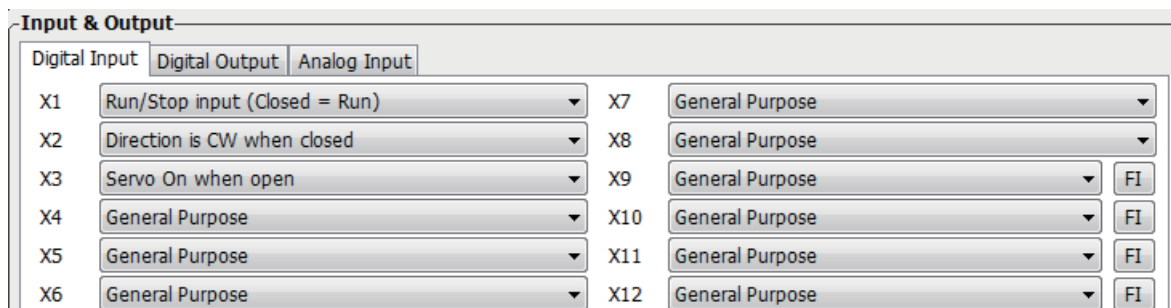

7.4.3.6 Velocity Limit

In analog torque mode, if no limit is set on the motor's velocity, and the load inertia is small, the motor's velocity will be very fast, and could damage the machinery. Therefore, it is very important to set a velocity limit.

The velocity limit for torque mode can be set via analog input 1 (ANA1).

Parameter Settings

Parameter	Name	Data Range	Default value	Unit	Description
P-55 (AS)	Analog type	0 - 1	0		analog input type: 0: single ended input 1:differential input
P-61 (FA1)	Analog 2 function setting	1 - 3	3		analog input 1 function type: 1: velocity limit 3: not in use
P-50 (AG)	Analog Velocity Gain	-100 - 100	10	Rps	Sets correspondening velocity value against 10VDC input voltage.

Setting Via Software

Input & Output

Digital Input | Digital Output | Analog Input

Analog Input Filter

500 Hz

Analog Input 1

Range: ± 10V

Speed: 100.000 rps at +10V

Offset: 0.000 V Auto Offset

Deadband: 50 mV

Analog Signal Type

Differential Single Ended

Analog Input2

Range: ± 10V

Current: 1.50 Amps at +10V

Offset: 0.000 V Auto Offset

Deadband: 50 mV

7.4.3.7 Target Torque Reached

In torque mode, when the motor's actual torque and commanded torque are the same, a "torque reached" output signal can be sent via the Y3 output.

The first digit (from right to left) of parameter P-68 (MO) from the drive defines the output signal Y3.

Signal Name	PIN	P-67 (MO)	Condition	Function
Y3	Y3 (42) OUT- (33)	□□□9	Closed	Closed means target torque not reached
			Open	Open means output torque reached
		□□□8	Closed	Close means output torque reach
			Open	Open means target torque not reached
		□□□3 (default)		General purpose signal, function disabled.

Parameter Settings

Parameter	Name	Data Range	Default value	Unit	Description
P-87 (TV)	Torque within ripple range, when torque reached function in use	0.00 - 3.00	0.00	A	When the actual torque output and the commanded torque are the same, and within the velocity ripple range the torque reached output signal will be sent

NOTE: if you need to view or set this value on the drive's control panel, refer to the following calculation:

$$\text{LED display value} = \text{Torque ripple range} \times 100$$

Unit for torque ripple range is A (amps)

Setting Via Software

Input & Output

Digital Input Digital Output Analog Input

<table style="width: 100%; border-collapse: collapse;"> <tr> <td style="width: 20%;">Y1</td> <td style="border: 1px solid gray; padding: 2px;">General Purpose</td> </tr> <tr> <td>Y2</td> <td style="border: 1px solid gray; padding: 2px;">General Purpose</td> </tr> <tr> <td>Y3</td> <td style="border: 1px solid gray; padding: 2px;">Closed to torque limit</td> </tr> </table>	Y1	General Purpose	Y2	General Purpose	Y3	Closed to torque limit	<table style="width: 100%; border-collapse: collapse;"> <tr> <td style="width: 20%;">Y4</td> <td style="border: 1px solid gray; padding: 2px;">General Purpose</td> </tr> <tr> <td>Y5</td> <td style="border: 1px solid gray; padding: 2px;">General Purpose</td> </tr> <tr> <td>Y6</td> <td style="border: 1px solid gray; padding: 2px;">General Purpose</td> </tr> </table>	Y4	General Purpose	Y5	General Purpose	Y6	General Purpose
Y1	General Purpose												
Y2	General Purpose												
Y3	Closed to torque limit												
Y4	General Purpose												
Y5	General Purpose												
Y6	General Purpose												

Torque Reach Condition Setting

Current Ripple Range A

7.4.4 Software Configuration for Analog Torque Mode

The M Servo Suite can help you easily configure the drive and motor, and set the tuning parameters.

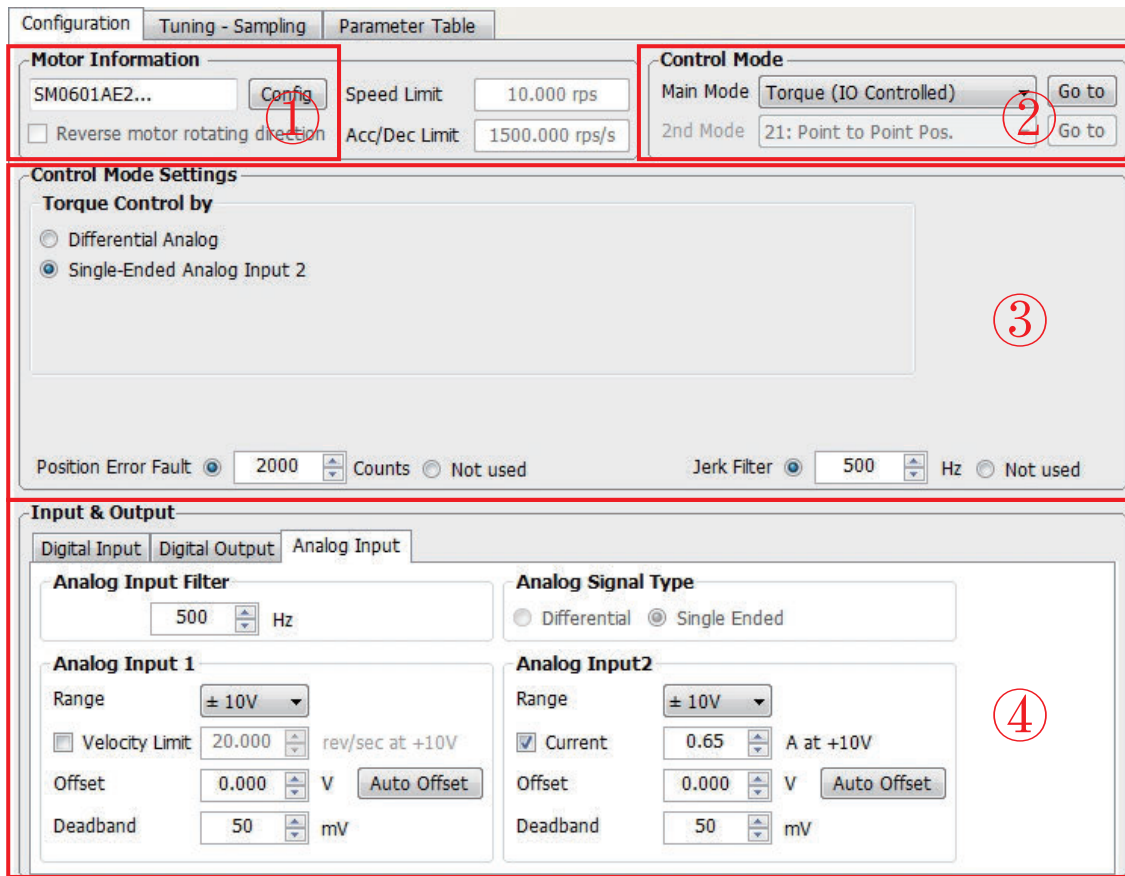

Step	Operation	Description
Step 1	Configure motor	Choose your motor model. Refer to Section 2.3 for motor details.
Step 2	Choose control mode	In Control Mode, choose “torque” for Torque Mode
Step 3	Control mode configuration	Select preferred torque analog type. Refer to Section 7.4 for analog torque mode.
Step 4	Set analog signal function, or digital input/output functions	Set analog input functions in Input & Output. Refer to Section 4.8.3 for CN2 connections, Section 7.4 for torque mode, and Section 7.1 for general function settings.

7.5 Position Table Mode

Position table mode allows **Point-to-Point linear motion** and **Rotary motion** without any external pulse input. Instead, position table mode uses Input ports X7 - X12 to configure different position commands. Input X4 is the trigger for motion.

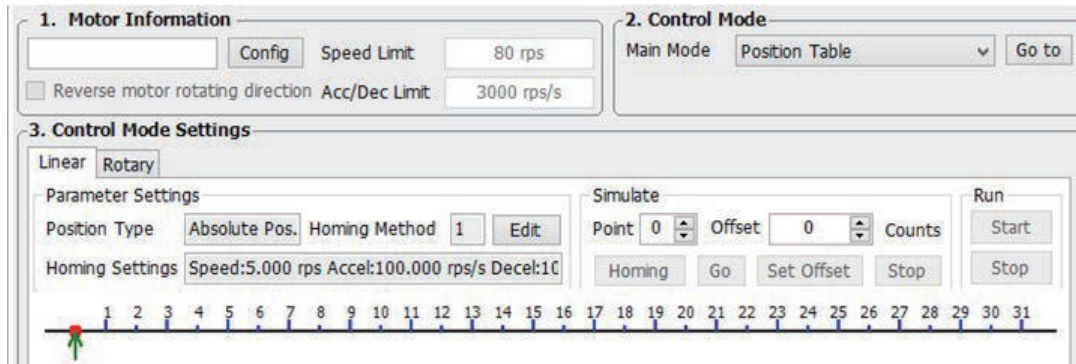

NOTE: Only -S type M2DC series servo drive supports position table mode

7.5.1 Linear motion

The Linear motion option for position table mode can set up to 63 positions, not including the homing position. It is set up through the M Servo Suite software.

7.5.1.1 Linear Motion Software Configuration

- Open M Servo Suite, connect the driver with the software
- Select Position Table under 2. Control Mode:

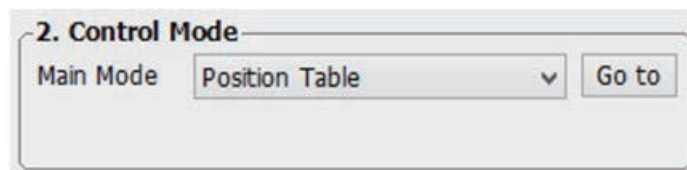

- Select the Linear tab under 3. Control Mode Settings:

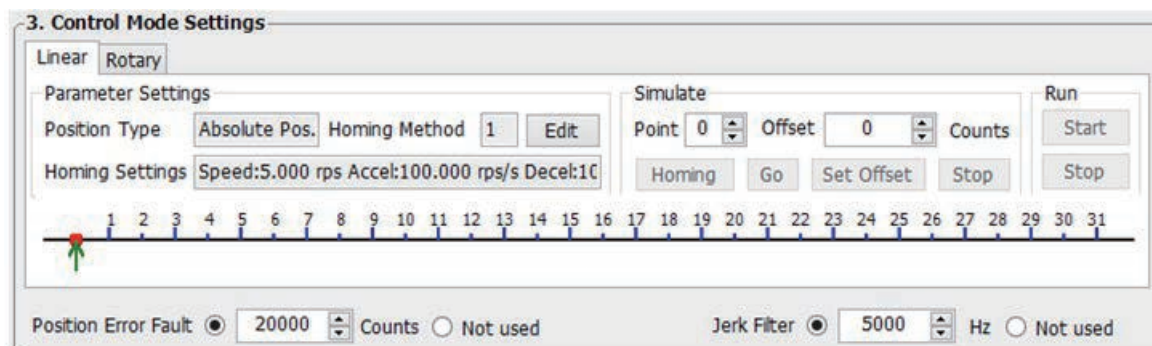

- Click Edit for detailed motion configurations.

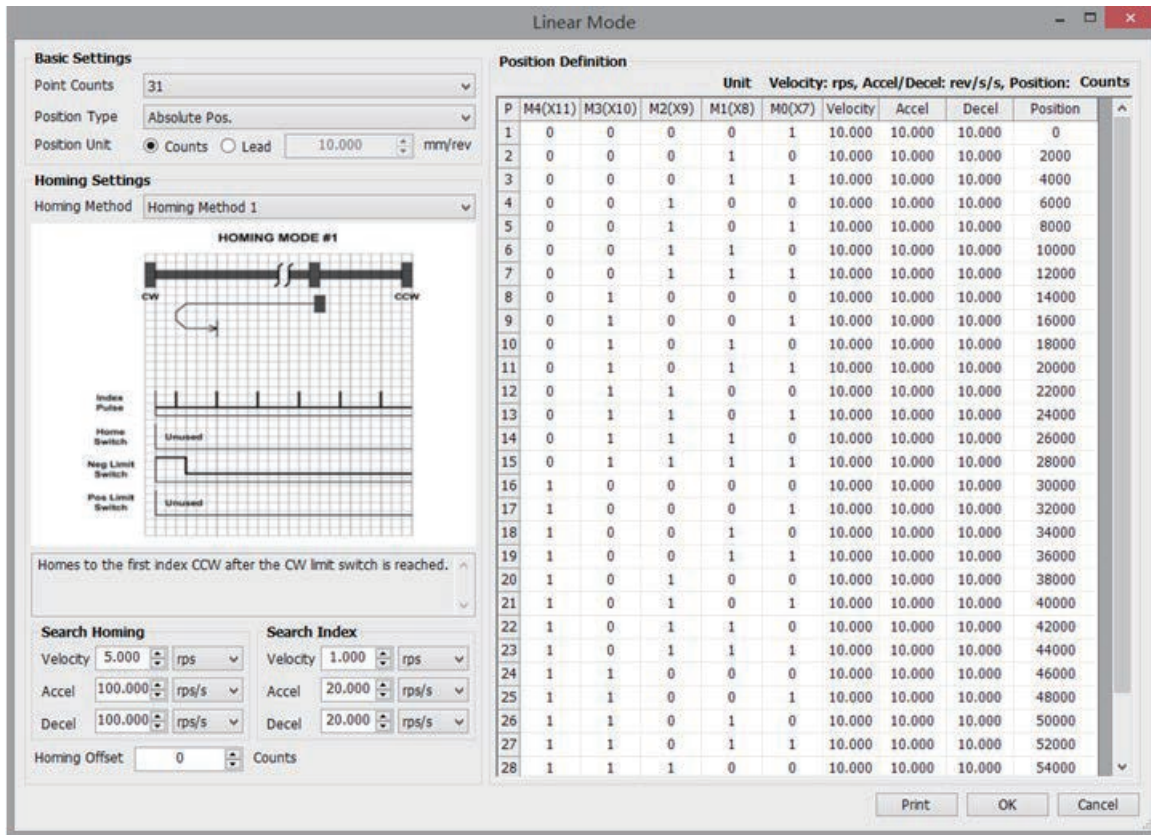

7.5.1.2 Basic Configuration

Point Counts: Select the number of position Point Counts: 7, 15, 31, or 63.

Position type: There are two types of point-to-point motion: Relative Position and Absolute Position.

The following graphs illustrate the difference between Relative positioning and Absolute positioning. Example: Set the P1 position for 5 revs and the P2 position for 10 revs.

The difference between Relative Position and Absolute Position is shown below:

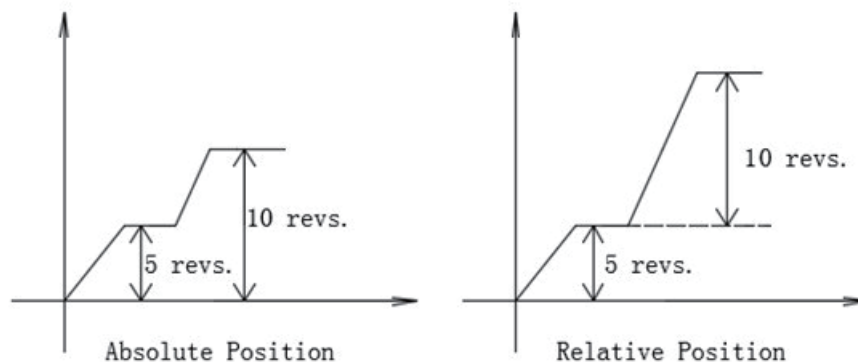

Position Unit: Set Position Units as Counts or Lead.

- **Counts** represents the number of pulses from the encoder output. For Position Table mode, one motor revolution is 10000 pulse counts.
- **Lead** represents the distance for one motor revolution in units of mm/rev.

7.5.1.3 Homing settings

Homing Method: There are 12 types of homing available.

Search Homing: Sets the velocity, acceleration and deceleration while searching for the homing switch.

Search Index: This feature sets the velocity, acceleration and deceleration while searching for the motor encoder index signal after the homing switch has been reached.

Homing Offset: After the homing process has finished, this sets the offset value from the home position.

7.5.1.4 Print

Click Print to print out the configuration table,

Position Table Configuration. ©Shanghai AMP & MOONS' Automation Co., Ltd.
 Linear Mode
 Point Counts: 31
 Position Type: Absolute Pos.
 Homing Method: Homing Method 1
 Search Homing
 Velocity: 5 rev/s Accel: 100 rev/s/s Decel: 100 rev/s/s
 Search Index
 Velocity: 5 rev/s Accel: 100 rev/s/s Decel: 100 rev/s/s
 Homing Offset: 0

Position Definition

P	M4(X11)	M3(X10)	M2(X9)	M1(X8)	M0(X7)	Unit	Velocity: rps	Accel/Decel: rev/s/s	Position:	
1	0	0	0	0	1		10.000	10.000	10.000	0
2	0	0	0	1	0		10.000	10.000	10.000	2000
3	0	0	0	1	1		10.000	10.000	10.000	4000
4	0	0	1	0	0		10.000	10.000	10.000	6000
5	0	0	1	0	1		10.000	10.000	10.000	8000
6	0	0	1	1	0		10.000	10.000	10.000	10000
7	0	0	1	1	1		10.000	10.000	10.000	12000
8	0	1	0	0	0		10.000	10.000	10.000	14000
9	0	1	0	0	1		10.000	10.000	10.000	16000
10	0	1	0	1	0		10.000	10.000	10.000	18000
11	0	1	0	1	1		10.000	10.000	10.000	20000
12	0	1	1	0	0		10.000	10.000	10.000	22000
13	0	1	1	0	1		10.000	10.000	10.000	24000
14	0	1	1	1	0		10.000	10.000	10.000	26000
15	0	1	1	1	1		10.000	10.000	10.000	28000

7.5.1.5 Position Definition

Position Definition shows the detailed configuration for each position point, including velocity, acceleration, deceleration, and position. This table, also shows the input condition of X7 - X12 to select each position.

Position Definition

P	M5(X12)	M4(X11)	M3(X10)	M2(X9)	M1(X8)	M0(X7)	Unit	Velocity: rps	Accel/Decel: rev/s/s	Position:	
1	0	0	0	0	0	1		10.000	10.000	10.000	0.000
2	0	0	0	0	1	0		10.000	10.000	10.000	2.000
3	0	0	0	0	1	1		10.000	10.000	10.000	4.000
4	0	0	0	1	0	0		10.000	10.000	10.000	6.000
5	0	0	0	1	0	1		10.000	10.000	10.000	8.000
6	0	0	0	1	1	0		10.000	10.000	10.000	10.000
7	0	0	0	1	1	1		10.000	10.000	10.000	12.000
8	0	0	1	0	0	0		10.000	100.000	100.000	14000.000
9	0	0	1	0	0	1		10.000	100.000	100.000	16000.000
10	0	0	1	0	1	0		10.000	100.000	100.000	18000.000
11	0	0	1	0	1	1		10.000	100.000	100.000	20000.000
12	0	0	1	1	0	0		10.000	100.000	100.000	22000.000
13	0	0	1	1	0	1		10.000	100.000	100.000	24000.000
14	0	0	1	1	1	0		10.000	100.000	100.000	26000.000
15	0	0	1	1	1	1		10.000	100.000	100.000	28000.000
16	0	1	0	0	0	0		10.000	100.000	100.000	30000.000
17	0	1	0	0	0	1		10.000	100.000	100.000	32000.000
18	0	1	0	0	1	0		10.000	100.000	100.000	34000.000
19	0	1	0	0	1	1		10.000	100.000	100.000	36000.000
20	0	1	0	1	0	0		10.000	100.000	100.000	38000.000
21	0	1	0	1	0	1		10.000	100.000	100.000	40000.000
22	0	1	0	1	1	0		10.000	100.000	100.000	42000.000
23	0	1	0	1	1	1		10.000	100.000	100.000	44000.000
24	0	1	1	0	0	0		10.000	100.000	100.000	46000.000
25	0	1	1	0	0	1		10.000	100.000	100.000	48000.000
26	0	1	1	0	1	0		10.000	100.000	100.000	50000.000

M0(X7) - M5(X12) status: '0' means the input is closed; '1' means the input is open.

After the homing process, the motor will move to the corresponding position selected by inputs M0(X7) - M5(X12), and triggered by X4 (position trigger) when it changes from 'open' to 'closed'.

- Click OK to finish linear mode settings
- Click Download to Drive to send it to the drive
- Close the software, turn off the power, then restart both the drive and the software to run Position Table mode.

7.5.1.6 Simulate

After the configuration process, 3. Control Mode Settings: Simulate can verify the settings and simulate the motions.

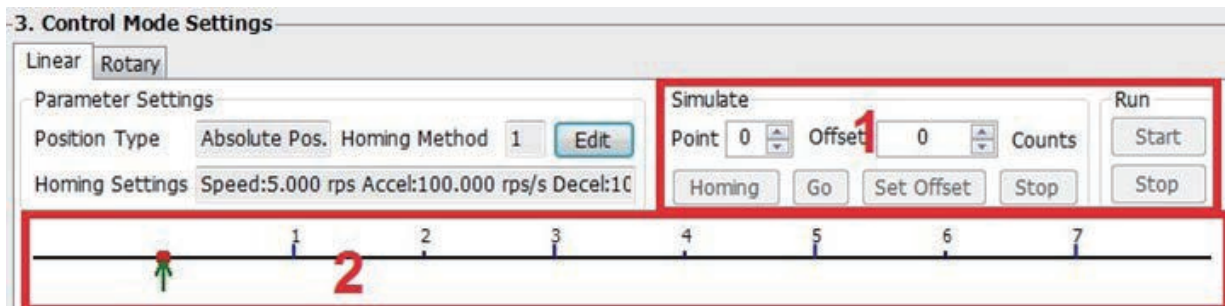

Homing: Click Homing to start the homing process.

Go: Set the position point by changing the value in the point box. Click the Go button to start the motion. The green arrow in the box above shows the load position in real time.

Set Offset: Confirm the offset position; the value in the Offset field will be used to update the position of the selected point in the position table.

Stop: Stops the current motion immediately

7.5.1.7 Linear motion input definition

Input	Function	Description
X1	Homing Sensor	Homing sensor switch
X2	Homing Trigger	Triggering homing process
X3	General Purpose	General purpose
	Servo On When Closed	Enable the motor drive when input closed
	Servo On When Open	Enable the motor drive when input open
X4	PositionTrigger	The trigger signal - when Input X4 changes from open to closed, motor will move to the position selected by switch M0(X7) - M5(X12)
X5	General Purpose	General purpose
	CW Limit Sensor	Sets CW position limit, refer to Section 7.1.3, CW/CCW Limit for more details
X6	General Purpose	General purpose
	CCW Limit Sensor	Sets CCW position limit, refer to Section 7.1.3, CW/CCW Limit for more details
X7 - X12	M Input	Position point input

7.5.2 Rotary motion

Rotary motion is useful for turntable (dividing plate) applications, allowing for a system gear reduction ratio setting that is based on the hardware. Settings such as the number of division per revolution, motion profiles and homing profiles can also be entered in the Rotary Mode configuration panel.

After configuration input X4 is the motion trigger. When X4 is triggered the load will rotate according to the specified direction. Each trigger signal will turn the load by one single rotary point based on the settings.

7.5.2.1 Rotary motion software configuration

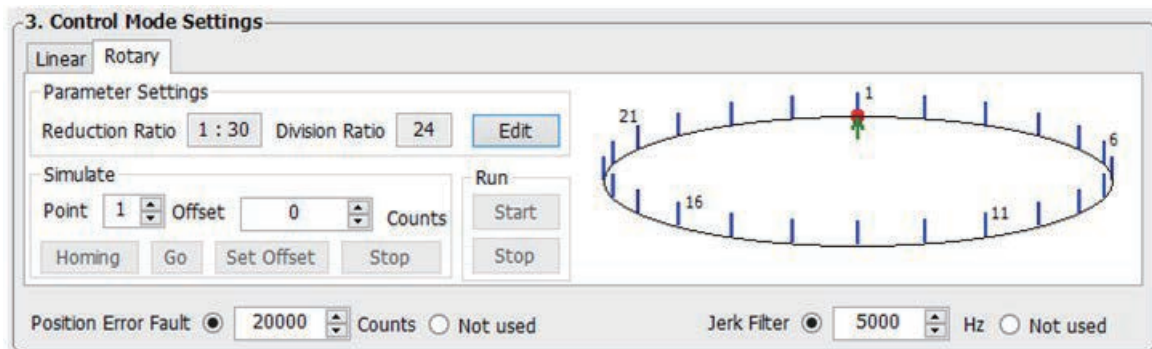

Edit: Click on 'Edit' to enter the detailed configuration page.

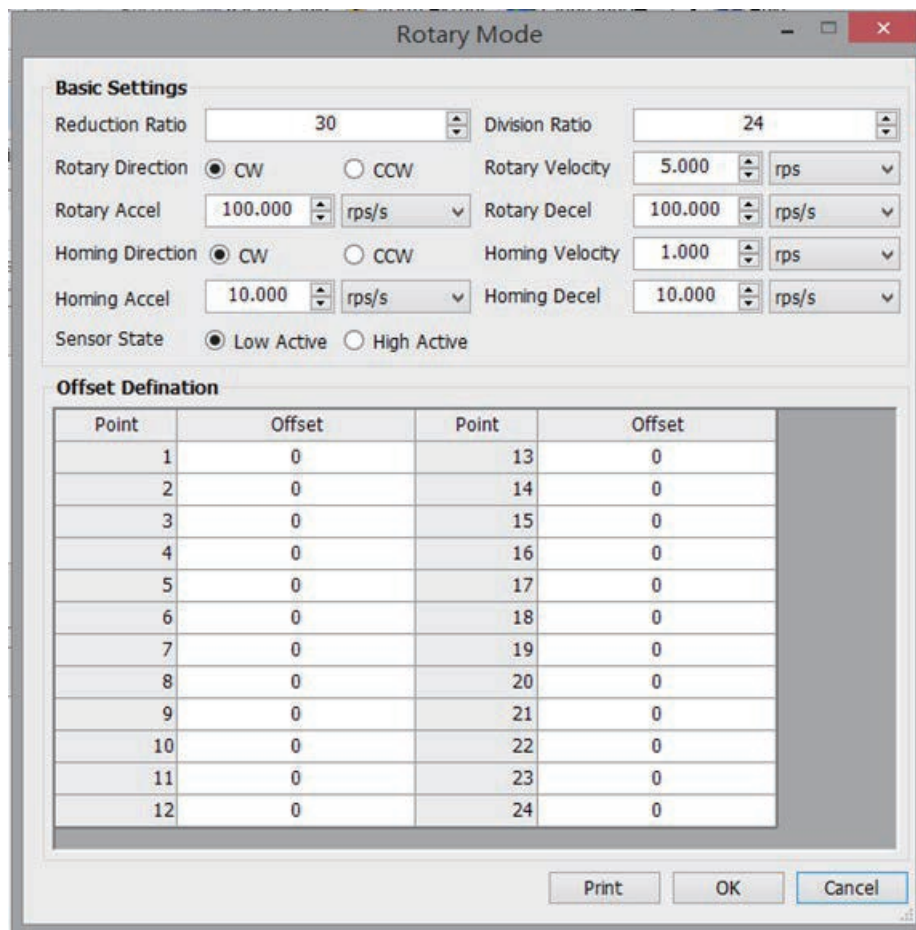

Reduction ratio: Sets mechanical gear box ratio

Division Ratio: Divide one revolution into that number of points with equal distance spacing

Rotary direction: Selects the direction for rotary motion

Rotary velocity, rotary acceleration, rotary deceleration: Set motor rotary velocity, rotary acceleration, and rotary deceleration values

NOTE: These setting affect the motor's velocity, acceleration, and deceleration. For actual system speed, accel and decel, refer to the ratio calculation below:

$$\text{System speed} = \text{Motor Speed} \times \text{Reduction ratio}$$

Homing direction: Set homing direction

Homing velocity, Homing acceleration, Homing deceleration: Set motor homing velocity, homing acceleration, and homing deceleration values

NOTE: These setting affect the motor's velocity, acceleration, and deceleration. For actual system speed, accel and decel, refer to the ratio calculation below:

$$\text{System speed} = \text{Motor Speed} \times \text{Reduction ratio}$$

Sensor State: Sets homing sensor type: low active or high active

Offset definition: Set position offset for each position point, for minor individual point adjustments.

7.5.2.2 Rotary motion input definition

Input	Function	Description
X1	Homing Sensor	Homing sensor switch
X2	Homing Trigger	Triggering homing process
X3	General Purpose	General purpose
	Servo On When Closed	Enable the motor drive when input is closed
	Servo On When Open	Enable the motor drive when input is open
X4	Position Trigger	Motion trigger signal. When Input X4 changes from open to closed, the load will move one single rotary point according to the position configuration.

8 Parameters and Functions

8.1 Parameter Category

M2DC series servo drives have 4 modes

Type	Function	Example	Details
n - Status Monitoring	Select LED monitoring status type		Section 5.4 Status Monitoring Selection Mode
F - Function Control	Select drive function to execute		Section 5.5 Function Control Mode
P - Parameter Setting	Select and edit the parameter on the drive		Section 5.6 Parameter Setting Mode
r - Warning & Fault Display	Display any warnings or faults when they occur		Section 5.8 Warning and Fault Display

8.2 Parameter List



Parameter number	Type	SCL command	LED display	Function	Default value	Unit
P00	PID	KP		Global gain 1	8000	
P01	PID	KG		Global gain 2	12000	
P02	PID	KF		Proportion gain	10000	
P03	PID	KD		Deriv gain	2000	
P04	PID	KV		Damping gain	8000	
P05	PID	KI		Integrator gain	150	
P06	PID	KK		Inertia Feedforward Constant	500	
P07	PID	KJ		Jerk Filter Frequency	5000	
P08	PID	VP		Velocity Loop Proportional Gain	15000	
P09	PID	VI		Velocity Loop Integral Gain	600	
P10	PID	KE		Deriv Filter factor	15000	
P11	PID	KC		PID Filter factor	25000	
P12	Control mode	CM		Main control mode	7	
P13	Control mode	CN		Secondary control mode	21	
P14	Control mode	PM		Power-up mode	2	
P15	Control mode	JM		Jog mode	2	

P16	Current config	GC	P 16GC	Current Command of Torque Mode	0	0.01A
P17	Current config	CC	P 17CC	Rated Maximum current	0.5 *	A
P18	Current config	CP	P 18CP	Peak current	1.5 *	A
P20	Profile	VM	P20VN	Maximum velocity	110.000	rps
P21	Profile	AM	P21AN	Maximum acceleration/deceleration	3000	rps/s
P22	Profile	JS	P22JE	Jog speed	10.000	rps
P23	Profile	JA	P23JA	Jog acceleration	100.00	rps/s
P24	Profile	JL	P24JL	Jog deceleration	100	rps/s
P25	Profile	VE	P25VE	Point to point Velocity	5	rps
P26	Profile	AC	P26AC	Point to point acceleration	100.00	rps/s
P27	Profile	DE	P27DE	Point to point deceleration	100.00	rps/s
P28	Profile	VC	P28VC	Point to point secondary velocity	2.000	rps
P29	Profile	JC1	P29JC	Jog mode speed 1	2.000	rps
P30	Profile	JC2	P30JC	Jog mode speed 2	10.000	rps
P31	Profile	JC3	P31JC	Jog mode speed 3	20.000	rps
P32	Profile	JC4	P32JC	Jog mode speed 4	25.000	rps
P33	Profile	JC5	P33JC	Jog mode speed 5	30.000	rps
P34	Profile	JC6	P34JC	Jog mode speed 6	35.000	rps
P35	Profile	JC7	P35JC	Jog mode speed 7	40.000	rps
P36	Profile	JC8	P36JC	Jog mode speed 8	50.000	rps
P37	Config	ER	P37ER	Encoder resolution	2500	lines
P39	Config	EG	P39EG	Electronic gearing	10000	counts/rev
P40	Config	PV	P40PV	Secondary Electronic gearing	20000	counts/rev
P41	Config	EN	P41EN	Numerator of electronic gearing ratio	1000	
P42	Config	EU	P42EU	Denominator of electronic gearing ratio	1000	
P43	Config	SZ	P43SZ	Input Pulse Setting	1792	
P44	Config	PF	P44PF	Position Fault limit	2000	counts
P45	Config	PL	P45PL	Dynamical Position error Range	10	counts

P46	Config	PD	P46Pd	In Position Error Range	10	counts
P47	Config	PE	P47PE	In position duration count	10	counts
P48	Config	TT	P48tE	Pulses Input Completion count	2	ms
P49	Analog	AP	P49AP	Analog Position Gain	8000	counts
P50	Analog	AG	P50AG	Analog Velocit Gain	20.000	rps
P51	Analog	AN	P51An	Analog Torque Gain	1.00	A
P52	Analog	AV1	P52Av	Analog input1 offset	0.000	V
P53	Analog	AV2	P53Av	Analog input2 offset	0.000	V
P54	Analog	AV3	P54Av	Differential analog input offset	0.000	V
P55	Analog	AS	P55As	Analog type	0	
P56	Analog	AD1	P56Ad	Analog input1 deadband	0	mv
P57	Analog	AD2	P57Ad	Analog input2 deadband	0	mv
P58	Analog	AD3	P58Ad	Differential analog deadband	0	mv
P59	Analog	AF	P59AF	Analog input low pass filter value	500	Hz
P60	Analog	AT	P60At	Analog threshold	0.000	V
P61	Analog	FA	P61FA	Analog 1/2 function	33	
P62	I/O	SI	P62Si	Servo enable input setting	2	
P63	I/O	AI	P63Ai	Alarm Reset input setting	1	
P64	I/O	DL	P64dL	End-of –travel limit Setting	3	
P65	I/O	MI	P65Mi	X7□X8□X9□X10 input function setting	3333	
P66	I/O	AO	P66Ao	Alarm output function setting	1	
P67	I/O	BO	P67bo	Motor brake control setting	1	
P68	I/O	MO	P68Mo	Y3□Y4□Y5□Y6 output function setting	413D	
P69	I/O	BD	P69bd	Brake disengage Delay	200	ms
P70	I/O	BE	P70bE	Brake engage delay	200	ms
P71	I/O	FI1	P71Fi	Input X9 noise filter	0	
P72	I/O	FI2	P72Fi	Input X10 noise filter	0	

P73	I/O	FI3	P73F	Input X11 noise filter	0	
P74	I/O	FI4	P74F	Input X12 noise filter	0	
P76	communication	PR	P76Pr	Communication protocol	15	
P77	communication	TD	P77td	Transmit delay	2	
P78	communication	BR	P78br	Baud rate	1	
P79	communication	DA	P79dA	RS-485 Address	32	
P80	communication	CO	P80Co	CANopen Node ID	1	
P81	communication	CB	P81Cb	CANopen Baudrate	0	
P82	Regeneration	ZR	P82Zr	Regen resistor value	40	Ω
P83	Regeneration	ZC	P83ZC	Regen resistor continuous wattage	200	w
P84	Regeneration	ZT	P84Zt	Regen resistor peak time	125.00	ms
P85	Other	VR	P85Vr	Ripple range setting for velocity reach	0.000	rps
P86	Other	TO	P86To	Tach out counts	0	
P87	Other	TV	P87Tv	Ripple range setting for torque reach	0.00	A
P88	Other	PK	P88Pκ	Parameter lock on the drive's control panel	0	
P89	Other	DD	P89dd	LED Default status monitor type	0	
P90	Other	MA	P90MA	LED Warning Display Mask Code	65535	
P91	Other	HA1	P91HA	Accel of seeking end-of-travel limit during homing	100	rps/s
P92	Other	HA2	P92HA	Accel of seeking homing switch during homing	100	rps/s
P93	Other	HA3	P93HA	Accel of feeding to homing switch during homing	10	rps/s
P94	Other	HL1	P94HL	Decel of seeking end-of-travel limit during homing	100	rps/s
P95	Other	HL2	P95HL	Decel of seeking homing switch during homing	100	rps/s
P96	Other	HL3	P96HL	Decel of feeding to homing switch during homing	10	rps/s
P97	Other	HV1	P97Hv	Velocity of seeking end-of-travel limit during homing	10	rps
P98	Other	HV2	P98Hv	Velocity of seeking homing switch during homing	5	rps
P99	Other	HV3	P99Hv	Velocity of feeding to homing switch during homing	0.5	rps

* This parameter depends on the motor model.

P100	PID	KL		Follow factor	0	
P101	Other			Select motor rotation	0	

8.3 Parameter Description

P-00 (KP)	Global gain 1	Data Range	Default	Unit	Data type
		0 - 32767	8000	-----	DEC

Sets or requests the servo control proportional gain term. Gain value is relative: "0" meaning no gain, "32767" meaning full gain. This parameter is the primary gain term for minimizing the position error. Larger KP value means higher stiffness, and fast response. However, if the gain value is too high, it will lead to vibration.

Use input X7 for global gain selection. When the gain selection function is used, it helps the servo drive to run the motor with the least time delay and as close as possible to the host command requirement. Especially in the case of the load characteristic changing significantly, change of gain value will reduce the motor's settling time, motor vibration, etc. It optimizes the motor's overall performance. The two global gain parameters are: P-00 (KP), and P-01 (KG).

P-01 (KG)	Global gain 2	Data Range	Default	Unit	Data type
		0 - 32767	12000	-----	DEC

Sets or requests the secondary servo control proportional gain term. Gain value is relative: "0" meaning no gain, "32767" meaning full gain. This parameter is the primary gain term for minimizing the position error. A larger KG value means higher stiffness, and fast response. However, if the gain value is too high, it will lead to vibration.

P-02 (KF)	Proportion gain	Data Range	Default	Unit	Data type
		0~32767	10000	-----	DEC

The servo control proportional gain term. Gain value is relative: "0" meaning no gain, "32767" meaning full gain. This parameter is the primary gain term for minimizing the position error. Increase of KF will increase stiffness and reduce in position time duration. However, it might cause vibration if gain is too large.

P-03 (KD)	Deriv gain	Data Range	Default	Unit	Data type
		0~32767	2000	-----	DEC

The servo control differential gain. Gain value is relative: "0" meaning no gain, "32767" meaning full gain. It works to damp low speed oscillations.

P-04 (KV)	Damping gain	Data Range	Default	Unit	Data type
		0~32767	8000	-----	DEC

The servo control proportional gain term of the velocity error. Gain value is relative: "0" meaning no gain, "32767" meaning full gain. KV minimizes the velocity error and vibration in position control mode.

P-05 (KI)	Integrator gain	Data Range	Default	Unit	Data type
		0~32767	150	-----	DEC

The servo control integrator gain term. Gain value is relative: “0” meaning no gain, “32767” meaning full gain. It minimizes (or may even eliminate) position errors especially when holding position.

P-06 (KK)	Inertia Feedforward Constant	Data Range	Default	Unit	Data type
		0~32767	0	-----	DEC

The servo control inertia feed forward gain. Gain value is relative: “0” meaning no gain, “32767” meaning full gain. KK improves acceleration control by compensating for the load inertia.

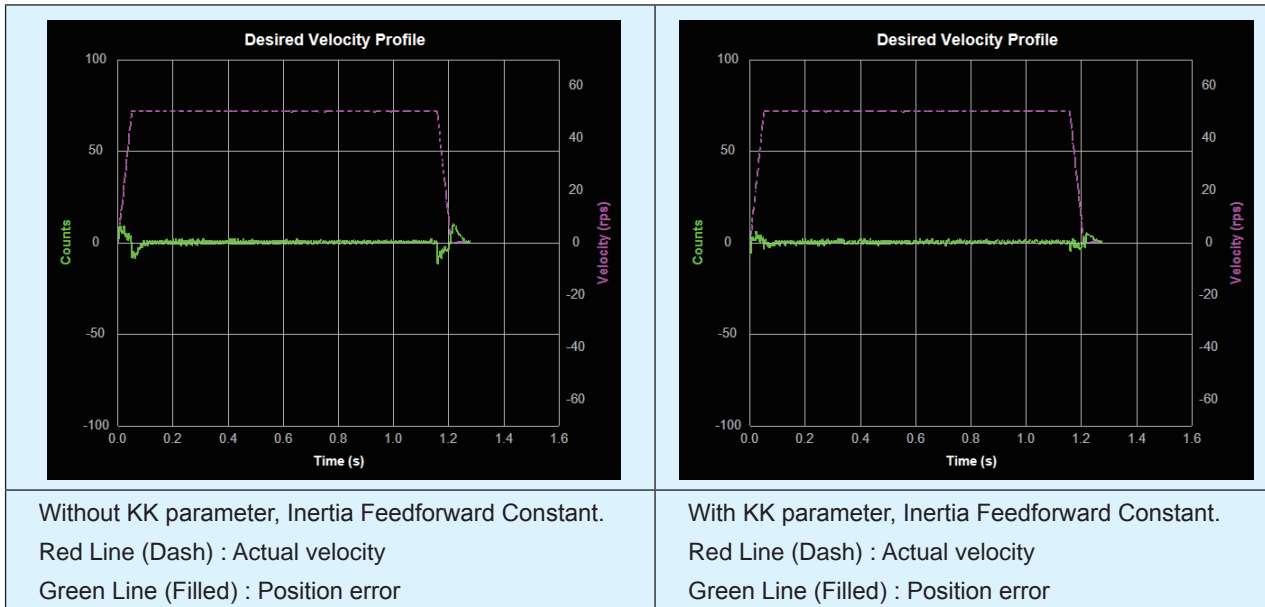

P-07 (KJ)	Jerk Filter Frequency	Data Range	Default	Unit	Data type
		0~5000	5000	-----	DEC

This parameter sets the jerk filter frequency in Hz . The lower the frequency value the more pronounced the S-curve profile will be. Setting the value to 0 will disable the filter.

S-curve acceleration/deceleration ramps are beneficial in positioning systems where instantaneous changes in speed may cause the load to jerk excessively. One example is when the load is connected to the motion actuator via a long movement arm. If the arm is not sufficiently rigid, changes in speed at the actuator can result in undesirable oscillations and increased settling time at the load. Smoothed transitions in speed changes can alleviate this unwanted motion and reduce settling time.

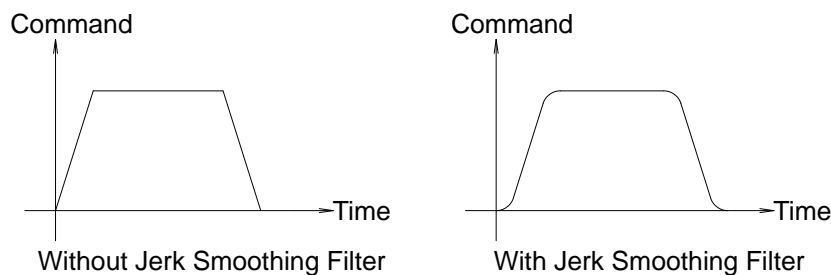

P-08 (VP)	Velocity Loop Proportional Gain	Data Range	Default	Unit	Data type
		0~32767	15000	-----	DEC

The velocity-mode servo control proportional gain term. Gain value is relative: “0” meaning no gain, “32767” meaning full gain. VP minimizes velocity error when in velocity mode 2.

P-09 (VI)	Velocity Loop Integral Gain	Data Range	Default	Unit	Data type
		0~32767	600	-----	DEC

The velocity-mode (“JM2”) servo control integrator gain term. Gain value is relative: “0” meaning no gain, “32767” meaning full gain. VI minimizes steady state velocity errors.

P-10 (KE)	Deriv Filter factor	Data Range	Default	Unit	Data type
		0~32767	15000	-----	DEC

The differential control parameters filter frequency. The filter is a simple one-pole, low-pass filter intended for attenuating high frequency oscillations. The value is a constant that must be calculated from the desired roll-off frequency.

P-11 (KC)	PID Filter factor	Data Range	Default	Unit	Data type
		0~32767	20000	-----	DEC

The servo control overall filter frequency. The filter is a simple one-pole, low-pass filter intended for attenuating high frequency oscillations. The value is a constant that must be calculated from the desired roll-off frequency.

P-12 (CM)	Main control mode	Data Range	Default	Unit	Data type
		1~8,11,12, 15~18,21,22,25	7	-----	DEC

Parameter P-12 (CM) is used to set drive’s control mode.

Parameter mode list are as follows:

Mode	Control Signal	P-12 (CM)	Description
SCL command mode	SCL command	1	Use SCL command to control motor’s output torque
Analog input torque mode	+10 - -10V analog signal	2	Use external analog voltage input signal to control motor’s output torque. Analog torque mode: No run/stop signal, No direction signal.
Analog input torque mode	+10 - -10V analog signal	3	Analog torque mode: no run/stop signal; X2 is closed, motor will change its current rotary direction.
Analog input torque mode	+10 - -10V analog signal	4	Analog torque mode: no run/stop signal; X2 is open, motor will change its current rotary direction.
Analog input torque mode	+10 - -10V analog signal	5	Analog torque mode: X1 for run/stop signal, No direction signal.

Analog input torque mode	+10 - -10V analog signal	6	Analog torque mode: X1 for run/stop signal; X2 is open, motor will change its current rotary direction.
Analog input torque mode	+10 - -10V analog signal	8	Analog torque mode: X1 for run/stop signal; X2 is closed, motor will change its current rotary direction.
Digital pulse position mode	STEP & Direction; CW/CCW Pulse; A/B Quadrature.	7	Up to 500KHz open collector input signal or up to 2MHz differential input signal.
Command velocity mode	SCL command	10	Use SCL command to control motor rotation velocity.
Analog velocity mode	+10 - -10V analog signal	11	Using external analog voltage input to motor velocity. Analog velocity mode, no run/stop signal, X2 is direction switch.
Analog velocity mode	+10 - -10V analog signal	12	Analog velocity mode, X1 is run/stop signal, X2 is direction switch
Velocity mode	Digital input signal	15	Profile velocity mode, after drive is enabled. The drive will run at velocity set by P-21 (JS). No run/stop signal, X2 is direction switch.
Velocity mode	Digital input signal	16	Profile velocity mode, after drive is enabled. The drive will run at velocity set by P-21 (JS). N run/stop signal, X2 is direction switch.
Multi velocity mode	Digital input signal	17	Profile velocity mode, no run/stop signal. X2 is direction switch. X10, X11, X12 are speed selection switches.
Multi velocity mode	Digital input signal	18	Profile velocity mode, X1 is run/stop switch. X2 is direction switch. X10, X11, X12 are speed selection switches.
Point to point Velocity	SCL command	21	Use SCL command to control point to point position mode.
Analog position mode	+10 - -10V analog signal	22	Use analog input voltage signal for position control .
Position table	Internal position mode	25	There are two motion control mode: linear motion with maximum of 64 position set points, and rotary motion with maximum of 32 position division points.

P-13 (CN)	Secondary control mode	Data Range	Default	Unit	Data type
		1~8,11,12, 15~18,21,22,25	21	-----	DEC

Servo drive's secondary control mode. Refer to P-12 (CM) main control mode, and Section 7.1.5 Control Mode Selection.

P-14 (PM)	Power-up mode	Data Range	Default	Unit	Data type
		2, 5, 7,8,9,10	2	-----	DEC

The power-up mode of the drive. PM determines how the drive is configured for serial communications at power-up. For example, for SCL applications set PM=2 or PM=5. The power-up mode can also be set when configuring the drive with Quick Tuner or ST Configurator. PM2 (Q / SCL) is the same as PM7 (Q Program Mode), except the program is not automatically executed at power up.

P-15 (JM)	Jog mode	Data Range	Default	Unit	Data type
		1, 2	2	-----	DEC

There are two Jog modes available:

JM 1: Jog Mode 1 uses position control that moves the target position which causes the servo to move at the set velocity. Jog Mode 1 will cause the servo motor to always move the same distance over time. A drawback is that the servo can fault if the position error during the move exceeds the value set by the PF (Position Fault) command.

JM 2: uses velocity control that applies torque to the motor to maintain velocity. This method functions better with high inertia loads because it ignores the value set by the PF (Position Fault) command. It also allows the drive to function in a “torque-limited velocity” mode or a “velocity-limited torque” mode. Jog Mode 2 also uses a different set of control parameters, VI and VP, for “tuning” the velocity mode.

P-16 (GC)	Current Command of Torque Mode	Data Range	Default	Unit	Data type
		Based on drive's output ability	0	0.01A	DEC

The immediate current for the servo motor and drive when the servo drive is set for Command Torque Mode.

NOTE: if you need to view or set this value on the drive's control panel, refer to the following calculation:

$$\text{LED display value} = \underline{B} \times 100$$

Where \underline{B} is target setting current, Unit for is A (amps)

P-17 (CC)	Rated Maximum current	Data Range	Default	Unit	Data type
		Depends on motor model	0.5	A	DEC

The continuous (RMS) current setting of the servo drive.

NOTE: In normal operation, please DO NOT change this parameter.

NOTE: if you need to view or set this value on the drive's control panel, refer to the following calculation:

$$\text{LED display value} = \underline{B} \times 100$$

Where \underline{B} is target setting current, Unit for is A (amps)

P-18 (CP)	Peak current	Data Range	Default	Unit	Data type
		Depends on motor model	1.5	A	DEC

CP sets the peak (RMS) current setting of the servo drive. Peak current sets the maximum current that should be used with a given motor. When the motor position requires more than the continuous value, the peak current time calculation is done using i^2t which integrates current values for more accurate modeling of drive and motor heating. The servo drive will allow peak current for up to one second. After one second of operation at peak current the current is reduced to the continuous current setting (see CC command).

NOTE: In normal operation, please DO NOT change this parameter.

NOTE: if you need to view or set this value on the drive's control panel, refer to the following calculation:

$$\text{LED display value} = \underline{B} \times 100$$

Where \underline{B} is target setting current, Unit for is A (amps)

P-20 (VM)	Maximum velocity	Data Range	Default	Unit	Data type
		0.025 - 100	110	rps	DEC

The maximum motor velocity in rev/sec. Used in all control modes to limit the maximum speed of the drive.

NOTE: if you need to view or set this value on the drive's control panel, refer to the following calculation:

$$\text{LED display value} = \underline{V} \times 240$$

Where \underline{V} is target velocity setting, Unit is rps (rev/sec).

P-21 (AM)	maximum acceleration/ deceleration	Data Range	Default	Unit	Data type
		0.167 - 5000	3000	rps/s	DEC

The maximum acceleration/deceleration allowed. When the targeted acceleration/deceleration exceeds the maximum value, the actual acceleration/deceleration will be limited to the maximum value.

Also sets the deceleration rate used when an end-of-travel limit is activated during a move or when an ST (Stop) or SK (Stop & Kill) command is sent.

NOTE: if you need to view or set this value on the drive's control panel, refer to the following calculation:

$$\text{LED display value} = \underline{B} \times 6$$

Where \underline{B} is target maximum acceleration/deceleration setting, Unit is rps/s.

P-22 (JS)	Jog velocity	Data Range	Default	Unit	Data type
		0.025 - 100	10	rps	DEC

The speed for Jog moves in rev/sec.

NOTE: If you need to view or set this value on the drive's control panel, refer to the following calculation:

$$\text{LED display value} = \underline{V} \times 240$$

Where \underline{V} is target velocity setting, Unit is rps (rev/sec) .

P-23 (JA)	Jog acceleration	Data Range	Default	Unit	Data type
		0.167 - 5000	100	rps/s	DEC

The accel/decel rate for Jog moves and velocity control mode in rev/sec/sec. Setting JA overwrites both the last JA and JL values. This means that to have different jog accel and jog decel values, you should first send JA to set the jog accel and then send JL to set the jog decel.

NOTE: if you need to view or set this value on the drive's control panel, refer to the following calculation:

$$\text{LED display value} = \underline{B} \times 6$$

Where \underline{B} is jog acceleration/deceleration setting, Unit is rps/s .

P-24 (JL)	Jog deceleration	Data Range	Default	Unit	Data type
		0.167 - 5000	100	rps/s	DEC

The accel/decel rate for Jog moves and velocity control mode in rev/sec/sec. Setting JA overwrites both the last JA and JL values. This means that to have different jog accel and jog decel values, you should first send JA to set the jog accel and then send JL to set the jog decel.

NOTE: if you need to view or set this value on the drive's control panel, refer to the following calculation:

$$\text{LED display value} = \underline{B} \times 6$$

Where \underline{B} is jog acceleration/deceleration setting, Unit is rps/s .

P-25 (VE)	Point to point Velocity	Data Range	Default	Unit	Data type
		0.025 - 100	5	rps	DEC

The shaft speed for point-to-point move commands like FL, FP, FS, FD, SH, etc.

NOTE: if you need to view or set this value on the drive's control panel, refer to the following calculation:

$$\text{LED display value} = \underline{V} \times 240$$

Where \underline{V} is target velocity setting, Unit is rps (rev/sec) .

P-26 (AC)	Point to point acceleration	Data Range	Default value	Unit	Data type
		0.167 - 5000	100	rps/s	DEC

The acceleration rate used in point-to-point move commands in rev/sec/sec.

NOTE: if you need to view or set this value on the drive's control panel, refer to the following calculation:

$$\text{LED display value} = \underline{B} \times 6$$

Where \underline{B} is point to point move acceleration setting, Unit is rps/s .

P-27 (DE)	Point to point deceleration	Data Range	Default	Unit	Data type
		0.167 - 5000	100	rps/s	DEC

The deceleration rate used in point-to-point move commands in rev/sec/sec.

NOTE: if you need to view or set this value on the drive's control panel, refer to the following calculation:

$$\text{LED display value} = \underline{B} \times 6$$

Where \underline{B} is point to point move deceleration setting, Unit is rps/s .

P-28 (VC)	speed change	Data Range	Default	Unit	Data type
		0.025 - 100	2	rps	DEC

The secondary speed for FC and FD moves.

NOTE: if you need to view or set this value on the drive's control panel, refer to the following calculation:

$$\text{LED display value} = \underline{V} \times 240$$

Where \underline{V} is target velocity setting, Unit is rps (rev/sec) .

P-29 (JC)	Jog mode speed 1	Data Range	Default	Unit	Data type
		0.025 - 100	2	rps	DEC

The first speed used in velocity mode. This only applies to control modes 15, 16, 17, and 18.

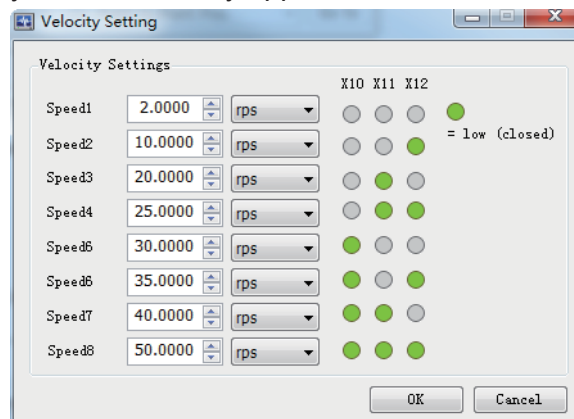

P-30 (JC)	Jog mode speed 2	Data Range	Default	Unit	Data type
		0.025 - 100	10	rps	DEC

The second speed used in velocity mode. This only applies to control modes 13, 14, 17, and 18.

P-31 (JC)	Jog mode speed 3	Data Range	Default	Unit	Data type
		0.025 - 100	20	rps	DEC

The third speed used in velocity mode. This only applies to control modes 13, 14, 17, and 18.

P-32 (JC)	Jog mode speed 4	Data Range	Default	Unit	Data type
		0.025 - 100	25	rps	DEC

The fourth speed used in velocity mode. This only applies to control modes 13, 14, 17, and 18.

P-33 (JC)	Jog mode speed 5	Data Range	Default	Unit	Data type
		0.025 - 100	30	rps	DEC

The fifth speed used in velocity mode. This only applies to control modes 13, 14, 17, and 18.

P-34 (JC)	Jog mode speed 6	Data Range	Default	Unit	Data type
		0.025 - 100	35	rps	DEC

The sixth speed used in velocity mode. This only applies to control modes 13, 14, 17, and 18.

P-35 (JC)	Jog mode speed 7	Data Range	Default	Unit	Data type
		0.025 - 100	40	rps	DEC

The seventh speed used in velocity mode. This only applies to control modes 13, 14, 17, and 18.

P-36 (JC)	Jog mode speed 8	Data Range	Default	Unit	Data type
		0.025 - 100	50	rps	DEC

The eighth speed used in velocity mode. This only applies to control modes 13, 14, 17, and 18.

P-37 (ER)	Encoder resolution	Data Range	Default	Unit	Data type
		200 - 12800	2500	lines	DEC

Sets the encoder resolution in quadrature counts. For example, if the motor connected to the drive has an 8000 count (2000 line) per revolution encoder, set the encoder resolution to 2000.

NOTE: when using a MOONS' motor please DO NOT change this parameter

P-39 (EG)	Electronic gearing	Data Range	Default	Unit	Data type
		200 - 32000	10000	counts	DEC

EG defines the pulses per revolution for electronic gearing. For example, with an EG value of 10000 the servo drive will require 10000 pulses from the master pulse source to move the servo motor 1 revolution.

P-40 (PV)	Secondary Electronic gearing	Data Range	Default	Unit	Data type
		200 - 32000	10000	counts	DEC

PV defines the pulses per revolution for secondary electronic gearing. Refer to Section 7.2.3 Control Pulse Dividing Switch Function.

P-41 (EN)	Numerator of electronic gearing ratio	Data Range	Default	Unit	Data type
		1 - 1000	1000		DEC

Defines the numerator of electronic gearing ratio. Refer to Section 7.2.5 Electronic Gearing Ratio.

P-42 (EU)	Denominator of electronic gearing ratio	Data Range	Default	Unit	Data type
		1 - 1000	1000		DEC

Defines the denominator of electronic gearing ratio. Refer to Section 7.2.5 Electronic Gearing Ratio.

P-43 (SZ)	Input Pulse Setting	Data Range	Default	Unit	Data type
		0 - 65535	1792		DEC

Pulse counter configuration and digital filter parameters in digital position control mode.

Bit0 - bit1: pulse type

0 = STEP/DIR

1 = CW/CCW

2 = A/B quadrature

bit2: count direction

Bit8 - bit15: digital filter parameter

Refer to Section 7.2.2 Input Pulse Type and Input Noise Filter

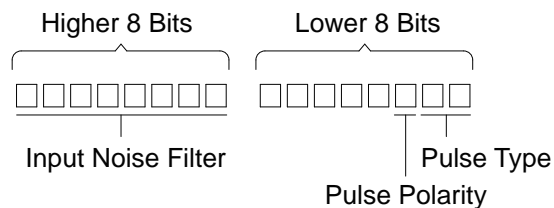

P-44 (PF)	Position Fault limit	Data Range	Default	Unit	Data type
		0 - 32000	2000		DEC

The position fault limit in encoder counts. This value defines the limit threshold, in encoder counts, reached between the actual position and the commanded position before the system produces a position fault error. The drive's LED display, will read  if a position limit fault occurs.

P-45 (PL)	Dynamical Position Error Range	Data Range	Default	Unit	Data type
		0 - 32000	10		DEC

Define the usage of input X10 as inhibiting the pulse input.

PI1: Inhibit the pulse input when input X10 is closed.

PI2: Inhibit the pulse input when input X10 is open.

PI3: Input X10 is used as general purpose input.

P-46 (PD)	In Position Error Range	Data Range	Default	Unit	Data type
		0 - 32000	10		DEC

This parameter is used to set the in-position error range. For example, motor is in position when the actual position is within the target In-position error range for the time that is longer than PE specified timing. Then the driver will define the motion as complete or motor is in-position. Refer to P-47 (PE) and Section 7.2.7 In-Position Error Output.

P-47 (PE)	In Position Duration Count	Data Range	Default	Unit	Data type
		0 - 32000	10	250us	DEC

PE sets the timing counts for in-range determination. For example, if In-Position error P-46 (PD) is defined, PE sets the time duration for the test. If In-Position is reached within the time duration, the drive will define the motor as In-Position. Time is counted as processor cycles, one cycle refers to 250µsec. Refer to Section 7.2.7 In-Position Error Output.

P-48 (TT)	Pulses Input Completion Count	Data Range	Default	Unit	Data type
		0 - 20000	16	125us	DEC

This parameter is used to define a time duration. It will determine whether the drive has finished receiving all pulses. If the drive has not receive any pulses for a period longer than TT defined time, then the drive will define no pluses sent to drive. One count is equivalent to 125µs.

P-49 (AP)	Analog Position Gain	Data Range	Default	Unit	Data type
		0 - 32000	8000	counts	DEC

AP sets the analog input gain for motor position when the drive is in analog position command mode. Gain value sets the commanded position when the analog input is at the configured full scale value.

P-50 (AG)	Analog Velocity Gain	Data Range	Default	Unit	Data type
		-100.000 - 100.000	20.000	rps	DEC

Analog gain value used in analog velocity modes. The gain value is used to establish the relationship between the analog input and the motor speed in units of 0.25 rpm. For example, if the analog input is scaled to 0 - 5 volt input and the gain is set to 2400, when 5 volts is read at the analog input the motor will spin at 10 rps.

TIP: To set the analog velocity gain to the desired value, multiply the desired motor speed in rps by 240, or the desired motor speed in rpm by 4.

NOTE: if you need to view or set this value on the drive's control panel, refer to the following calculation:

$$\text{LED display value} = \underline{V} \times 240$$

Where \underline{V} is target velocity setting, Unit is rps (rev/sec).

P-51 (AN)	Analog Torque Gain	Data Range	Default	Unit	Data type
		Drive's maximum current output ability	1.00	A	DEC

This parameter sets the analog input gain that relates to motor torque when the drive is in analog torque control mode. Analog torque gain value sets the commanded torque when the analog input is at the configured full scale value ($\pm 10V$).

P-52 (AV)	Analog input1 offset	Data Range	Default	Unit	Data type
		-10.000 - +10.000	0.000	A	DEC

The offset value of analog input 1 in volts. In some cases, even when host controls set the analog command to 0V, the servo motor might still rotate slowly. This is caused by voltage bias from the analog voltage supply. This can be adjusted by this offset value.

NOTE: if you need to view or set this value on the drive's control panel, refer to the following calculation:

$$\text{LED display value} = \underline{A} \times 2730$$

Where \underline{A} is voltage offset, Unit is V.

P-53 (AV)	Analog input 2 offset	Data Range	Default	Unit	Data type
		-10.000 - +10.000	0.000	A	DEC

The offset value of analog input 2 in volts. Refer to Section 7.4.3.3 Analog Input Voltage Offset.

P-54 (AV)	Differential analog input offset	Data Range	Default	Unit	Data type
		-10.000 - +10.000	0.000	A	DEC

The offset value of differential analog input in volts. Refer to Section 7.4.3.3 Analog Input Voltage Offset.

P-55 (AS)	Analog type	Data Range	Default	Unit	Data type
		0 - 1	0	----	DEC

This is the analog input scaling setting that determines what type of analog input scaling is desired.

0: single ended input

1: differential input

P-56 (AD)	Analog input 1 deadband	Data Range	Default	Unit	Data type
		0 - 255	0	mV	DEC

The analog deadband value of analog input 1 in millivolts. The deadband value is the zone around the “zeroed” value of the analog input. This deadband defines the area of the analog input range that the drive should interpret as “zero”. The deadband is an absolute value that is applied to either side of the zero point.

P-57 (AD)	Analog input 2 deadband	Data Range	Default	Unit	Data type
		0 - 255	0	mV	DEC

The analog deadband value of the analog input 2 in millivolts. The deadband value is the zone around the “zeroed” value of the analog input. This deadband defines the area of the analog input range that the drive should interpret as “zero”. The deadband is an absolute value that is applied to either side of the zero point.

P-58 (AD)	Differential analog deadband	Data Range	Default	Unit	Data type
		0 - 255	0	mV	DEC

The analog deadband value of the differential analog input in millivolts. The deadband value is the zone around the “zeroed” value of the analog input. This deadband defines the area of the analog input range that the drive should interpret as “zero”. The deadband is an absolute value that is applied to either side of the zero point.

P-59 (AF)	Analog input filter value	Data Range	Default	Unit	Data type
		1 - 15990	500	----	DEC

Applies a digital filter to the analog input(s). This is a simple single pole filter that rolls off the analog input. When analog input is used, there might be external interferences that affect the accuracy of the analog input voltage. In some cases, it will cause the motor to turn unexpectedly, or have unstable torque output. Therefore, an analog input filter is recommended. It is designed as a digital low pass filter; reasonable filter frequency can significantly improve the motor performance. Refer to Section 7.3.4 Analog Input Filter.

P-60 (AT)	Analog threshold	Data Range	Default	Unit	Data type
		-10.000 - 10.000	0.000	V	DEC

This sets the analog input threshold that is used by the Feed to Sensor command. The threshold value sets the analog voltage that determines a sensor state or a trigger value.

NOTE: if you need to view or set this value on the drive’s control panel refer to the following calculation:

$$\text{LED display value} = \underline{A} \times 1000$$

Where \underline{A} is target voltage value, Unit is V (volts).

P-61 (FA)	Analog X1, X2 function	Data Range	Default	Unit	Data type
		11 - 33	33	---	HEX

Defines the function of analog inputs X1 and X2, by two digits, from right to left.

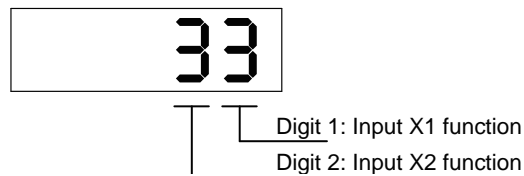

Input X1:

- 1: Analog input X1 is used as velocity or position reference input.
- 2: Not used.
- 3: Analog input X1 is used as general purpose analog input.

Input X2:

- 1: Not used.
- 2: Analog input X2 is used as torque reference input.
- 3: Analog input X2 is used as general purpose analog input.

In M Servo Suite Parameter Table tab, 2 commands are listed: FA1 represents the first digit (X1), and FA2 represents the second digit (from right to left).

SEQ	Category	Command	Unit	Software	Drive	Default	Range	Description(Double Click for Details)
060	Analog	FA1		3		3	1 - 3	Analog 1 Function
060	Analog	FA2		3		3	1 - 3	Analog 2 Function

P-62 (SI)	Servo enable input setting	Data Range	Default	Unit	Data type
		1, 2, 3	2	---	DEC

Input X3 is the default enable input on all drives. There are 3 possible usage states for the Enable function:

- SI1: Drive is enabled when X3 is open.
- SI2: Drive is enabled when X3 is closed.
- SI3: Input X3 is used as a general purpose input.

Refer to Section 7.1.1 Drive Servo On Settings.

P-63 (AI)	Alarm Reset input setting	Data Range	Default	Unit	Data type
		1, 2, 3	1	---	DEC

Defines the function of the X4 input. This input can be used to clear a drive fault and reset the Alarm Code (see AL command).

Refer to Section 7.1.2 Alarm Reset.

P-64 (DL)	End-of-travel limit Setting	Data Range	Default	Unit	Data type
		1-3,7-12,17-20	3	---	DEC

CW and CCW end-of-travel limits are available on all drives and can be used to define the boundaries of acceptable motion in a motor/drive system.

For example, define inputs X5 and X6 as dedicated end-of-travel limits. If one of these inputs is activated while defined as an end-of-travel limit, motor rotation will stop in that direction, and an alarm code will show on the drive's LED display.

If not needed, X5 and X6 can be redefined as general purpose inputs.

Refer to Section 7.1.3 CW/CCW Limit.

P-65 (MI)	X7, X8, X9, X10 input function setting	Data Range	Default	Unit	Data type
		1111 - 3333	3333	---	DEC

Defines the functions for X7, X8, X9, and X10 based on the value of the digits from right to left .

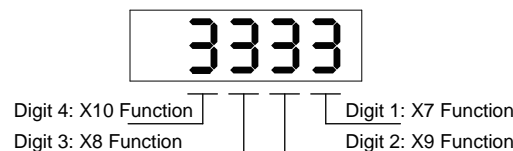

Digit 1 defines X7 for global gain control selection

- 1: When input X7 is open parameter KG is used, when closed parameter KP is used.
- 2: When input X7 is open parameter KP is used, when closed parameter KG is used.
- 3: X7 is used as a general purpose input, parameter KP is used.

Digit 2 defines X9 for electronic gearing selection

- 1: When input X9 is open parameter EG is used, when closed parameter PV is used.
- 2: When input X9 is open parameter PV is used, when closed parameter EG is used.
- 3: X9 is used as a general purpose input, parameter EG is used.

Digit 3 defines X8 control selection

- 1: When input X8 is open parameter CN is used, when closed parameter CM is used.
- 2: When input X8 is open parameter CM is used, when closed parameter CN is used.
- 3: X8 is used as a general purpose input.

Digit 4 defines X10 for pulse inhibition

- 1: When input X10 is closed pulse inhibition function is on
- 2: When input X10 is open pulse inhibition function is on
- 3: Input X10 is used as a general purpose

In M Servo Suite Parameter Table tab, 4 commands are listed: GS represents digit 1 (X7), DS represents digit 2 (X9), MS represents digit 3 (X8). PI represents digit 4 (X10).

SEQ	Category	Command	Unit	Software	Drive	Default	Range	Description(Double Click for Details)
064	I/O	DS		3		3	1 - 3	Dividing Select
064	I/O	GS		3		3	1 - 3	Gain Select
064	I/O	MS		3		3	1 - 3	Control Mode Select
064	I/O	PI		3		3	1 - 3	Pulse Inhibition

Refer to Section 7.1.4 Global Gain Selection, Section 7.1.5 Control Mode Selection, Section 7.2.3 [input electronic gearing selection](#), and Section 7.2.4 Pulse Inhibit.

P-66 (AO)	Alarm output function setting	Data Range	Default	Unit	Data type
		1~3	3	---	DEC

Defines usage of digital output Y1. Normally this output is used to indicate an Alarm caused by a Drive Fault. This output can be reconfigured as a general purpose output for use with other types of output commands. There are three states that can be defined: AO1: Output Y1 is closed (active, low) when a Drive Fault is present. AO2: Output Y1 is open (inactive, high) when an Drive Fault is present. AO3: Output Y1 is not used as an Alarm Output and can be used as a general purpose output.

P-67 (BO)	Motor brake control setting	Data Range	Default	Unit	Data type
		1 - 3	1	---	DEC

BO defines the usage of digital output Y2 as the Brake Output, which can be used to automatically activate and deactivate a holding brake. Output Y2 can also be configured as a general purpose output for use with other types of output commands. There are three states that can be defined:

BO1: Output Y2 is closed (energized) when the drive is enabled, and open when the drive is disabled.

BO2: Output Y2 is open (de-energized) when the drive is enabled, and closed when the drive is disabled.

BO3: Output Y2 is not used as a Brake Output and can be used as a general purpose output.

Refer to Section 7.1.7 Motor Brake Control.

P-68 (MO)	Y3, Y4, Y5, Y6 output function setting	Data Range	Default	Unit	Data type
			413D	---	HEX

P-68 (MO) defines Y3, Y4, Y5, and Y6 output functions, by 4 digits from right to left.

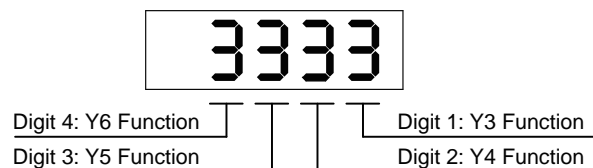

Digit 1 defines output Y3

8: When the output torque reaches the targeted torque, output Y3 is closed

9: When the output torque reaches the targeted torque, output Y3 is open

D: When the drive is in servo ready status, output Y3 is closed.

E: When the drive is in servo ready status, output Y3 is open.

3: Output Y3 is used as a general purpose output.

Digit 2 defines output Y4

6: When the dynamic position error is within the range specified by the PL command, output Y3 is closed.

7: When the dynamic position error is within the range specified by the PL command, output Y3 is open.

A: When the actual velocity reaches the targeted velocity, output Y3 is closed.

B: When the actual velocity reaches the targeted velocity, output Y3 is open.

3: Output Y3 is used as a general purpose output.

Digit 3 defines output Y5

1: When the drive is enabled, output Y5 is closed.

2: When the drive is enabled, output Y5 is open.

3: Output Y5 is used as a general purpose output.

Digit 4 defines output Y6

4: When the motion is completed and the motor is in position, output Y3 is closed.

5: When the motion is completed and the motor is in position, output Y3 is open.

C:When the motor is running, Y6 is set for tach output.

3: Output Y6 is used as a general purpose output.

In M servo suite Parameter Table tab, 4 commands are listed: MO1 represents digit 1 (Y3), MO2 represents digit 2 (Y4), MO3 represents digit 3 (Y5), MO4 represents digit 4 (Y6).

SEQ	Category	Command	Unit	Software	Drive	Default	Range	Description(Double Click for Details)
067	I/O	MO1		3		3	3, 8, 9	Motion Output 1
067	I/O	MO2		3		3	3, 6, 7, 10, 11	Motion Output 2
067	I/O	MO3		3		3	1, 2, 3	Motion Output 3
067	I/O	MO4		3		3	3, 4, 5, 12	Motion Output 4

P-69 (BD)	Brake disengage Delay	Data Range	Default	Unit	Data type
		0 - 32000	200	ms	DEC
P-70 (BE)	Brake engage delay	Data Range	Default	Unit	Data type
		0 - 32000	200	ms	DEC

BD only takes effect if the BO command is set to 1 or 2. After a drive is enabled this is the time value a move may be delayed waiting for the brake to disengage. When beginning a move the delay value must expire before a move can take place. The delay timer begins counting down immediately after the drive is enabled and the brake output is set. The delay is set in milliseconds.

BE only takes effect if the BO command is set to 1 or 2. After a drive is commanded to be disabled this is the time value the actual disabling of the drive output is delayed. When using the dedicated brake output (see BO command), the output is activated immediately with the disable command, then the drive waits the delay time before turning off the motor current.

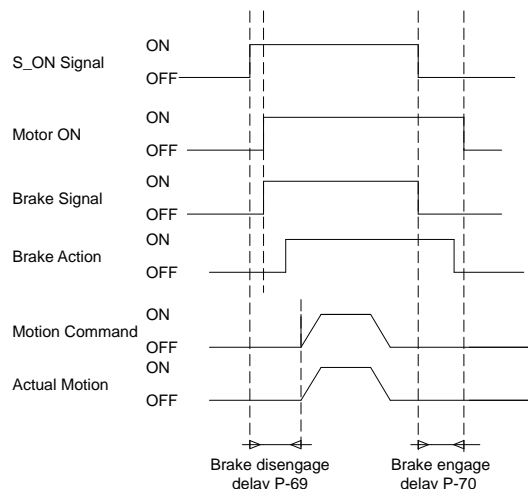

P-71 (FI)	Input X9 noise filter	Data Range	Default	Unit	Data type
		0 - 32767	0	---	DEC

Applies a digital filter to the input X9. The digital input must be at the same level for the time period specified by the FI command before the input state is updated. For example, if the time value is set to 100 the input must remain high for 100 processor cycles before high is updated as the input state. One processor cycle is 250µsec. A value of "0" disables the filter.

P-72 (FI)	Input X10 noise filter	Data Range	Default	Unit	Data type
		0 - 32767	0	---	DEC

Applies a digital filter to the input X10. The digital input must be at the same level for the time period specified by the FI command before the input state is updated. For example, if the time value is set to 100 the input must remain high for 100 processor cycles before high is updated as the input state. One processor cycle is 250µsec. A value of "0" disables the filter.

P-73 (FI)	Input X11 noise filter	Data Range	Default	Unit	Data type
		0 - 32767	0	---	DEC

Applies a digital filter to the input X11. The digital input must be at the same level for the time period specified by the FI command before the input state is updated. For example, if the time value is set to 100 the input must remain high for 100 processor cycles before high is updated as the input state. One processor cycle is 250µsec. A value of "0" disables the filter.

P-74 (FI)	Input X12 noise filter	Data Range	Default	Unit	Data type
		0 - 32767	0	---	DEC

Applies a digital filter to the input X12. The digital input must be at the same level for the time period specified by the FI command before the input state is updated. For example, if the time value is set to 100 the input must remain high for 100 processor cycles before high is updated as the input state. One processor cycle is 250µsec. A value of "0" disables the filter.

P-76 (PR)	Communication protocol	Data Range	Default	Unit	Data type
		1 - 127	15	---	DEC

The serial communication protocol settings. There are a number of settings that can be turned on or off in the PR command. Each setting is assigned a bit in an 8-bit binary word. The parameter of the PR command is the decimal equivalent of this word. If the PR command is sent without a parameter the drive will respond with the decimal equivalent of the word as well. The different protocol settings and their bit assignments are shown below.

Bit 0: Default ("Standard SCL")

Bit 1: Always use Address Character

Bit 2: Ack/Nack

Bit 3: Checksum (RESERVED)

Bit 4: RS-485 Adaptor

Bit 5: 3-digit numeric register addressing

Bit 6: Checksum Type

Bit 7: Little endian or big endian used in MODBUS type drive

Bit 8: Four wires/two wires for RS-485 communication

P-77 (TD)	Transmit delay	Data Range	Default	Unit	Data type
		0 - 100	2	---	DEC

The time delay used by the drive when responding to a command that requests a response. Typically this is needed when using the 2-wire RS-485 interface (half-duplex). Because the same wires are used to both receive and transmit a time delay is usually needed to allow transition time.

P-78 (BR)	Baud rate	Data Range	Default	Unit	Data type
		1 - 5	1	---	DEC

This parameter sets the bit rate (baud) for serial communications. At power up a drive will send its power-up packet detected after 1 second and the drive is configured for SCL or Q operation (see PM command) the drive will set the baud rate according to the value stored in the Baud Rate NV parameter. A Host system can set the baud rate at anytime using this command.

- | | |
|--------------|-------------|
| 1: 9600bps | 2: 19200bps |
| 3: 38400bps | 4: 57600bps |
| 5: 115200bps | |

P-79 (DA)	RS-485 Address	Data Range	Default	Unit	Data type
		1 - 32	32	---	DEC

The individual drive address character for multi-drop RS-485/MODBUS communications. This command is not required for single-axis (point-to-point) or RS-232 communications.

Modbus Address	SCL Address		Modbus Address	SCL Address
1	1		17	!
2	2		18	"
3	3		19	#
4	4		20	\$
5	5		21	%
6	6		22	&
7	7		23	'
8	8		24	(
9	9		25)
10	:		26	*
11	;		27	+
12	<		28	,
13	=		29	-
14	>		30	.
15	?		31	/
16	@		32	0

P-80 (CO)	CANopen Node ID	Data Range	Default	Unit	Data type
		1 - 127	1	---	DEC

The CANopen NODE-ID for CANOpen type drives. Also used for IP address selection on Ethernet drives.

P-80(CO)	IP Address	P-80(CO)	IP Address
0	10.10.10.10	8	192.168.0.80
1	192.168.1.10	9	192.168.0.90
2	192.168.1.20	A	192.168.0.100
3	192.168.1.30	B	192.168.0.110
4	192.168.0.40	C	192.168.0.120
5	192.168.0.50	D	192.168.0.130
6	192.168.0.60	E	192.168.0.140
7	192.168.0.70	F	DHCP

P-81 (CB)	CANopen Baudrate	Data Range	Default	Unit	Data type
		0 - 7	0	---	DEC

CANopen drives support 8 settings for the baud rate.

Setting value	Baud rate	Setting value	Baud rate
0	1M	4	125K
1	800K	5	50K
2	500K	6	25K
3	250K	7	12.5K

P-82 (ZR)	Regen resistor value	Data Range	Default	Unit	Data type
		0 - 1000	200	Ω	DEC

The regeneration resistor value. M2DC drives dynamically calculate the continuous wattage induced into an external regeneration resistor and must know the value of the regen resistor to do this effectively.

P-83 (ZC)	Regen resistor continuous wattage	Data Range	Default	Unit	Data type
		0 - 32000	40	W	DEC

The regeneration resistor wattage. M2DC drives calculate the continuous wattage induced into an external regeneration resistor and must know the continuous wattage rating of the regen resistor to do this effectively.

P-84 (ZT)	Regen resistor peak time	Data Range	Default	Unit	Data type
		0 - 8000	1250	ms	DEC

The regeneration resistor time constant. Calculates the peak time that the resistor can tolerate full regeneration voltage. The time is scaled as period count. One period is 250us.

P-85 (VR)	Ripple range setting for velocity reach	Data Range	Default	Unit	Data type
		0 - 136	0.000	rps	DEC

The velocity ripple value around the targeted velocity. If the difference between the actual velocity and targeted velocity is within the ripple value, the drive will define the actual velocity as having met the target velocity value.

Refer to Section 7.3.3.7 Target Velocity Reached.

P-86 (TO)	Tach out counts	Data Range	Default	Unit	Data type
			0	---	DEC

The count value of tach out per revolution.

- 0: 1 * pole pairs
- 1: 2 * pole pairs
- 2: 4 * pole pairs
- 3: 8 * pole pairs
- 4: 16 * pole pairs
- 5: 32 * pole pairs
- 6: 64 * pole pairs
- 7: 128 * pole pairs

P-87 (TV)	Ripple range setting for torque reach	Data Range	Default	Unit	Data type
		0.00 - 1.50	0.00	A	DEC

The torque ripple value around the targeted torque. If the difference between the actual torque and targeted torque is within the ripple value, the drive will define the actual torque as having met the target torque value.

Refer to Section 7.4.3.7 Target Torque Reached.

P-88 (PK)	Parameter lock on the drive's control panel	Data Range	Default	Unit	Data type
		0, 1	0		DEC

Determines whether the parameters of the driver can be modified directly from the push buttons on the driver's control panel.

- 0: Yes
- 1: No

P-89 (DD)	LED Default status monitor type	Data Range	Default	Unit	Data type
		0 - 14	0		DEC

Sets or requests the default monitor status on the driver's LED display.

P-90 (MA)	LED Warning Display Mask Code	Data Range	Default	Unit	Data type
		0 - 65535	65535		DEC

Some unwanted warnings from the drive's LED display can be masked to avoid constant flashing of the display. It is limited to certain warnings: CCW/CW Limits, under voltage, move while disabled, current foldback, blank Q segments, flash memory, and Comm error.

P-91 (HA)	Accel of seeking end-of-travel limit during homing	Data Range	Default	Unit	Data type
		0.167 - 5000	100	rps/s	DEC

In homing mode, this parameter sets the acceleration rate for seeking the end-of-travel limit.

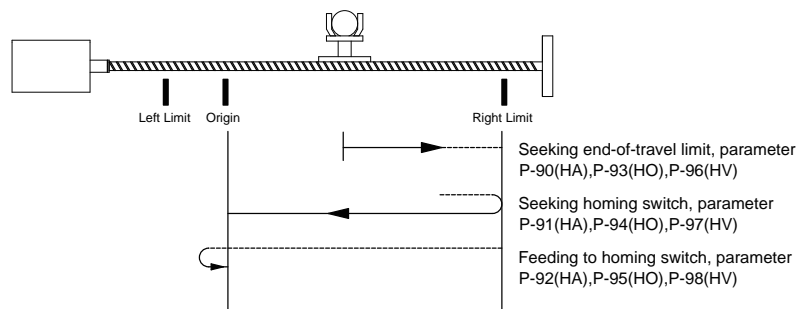

P-92 (HA)	Accel of seeking homing switch during homing	Data Range	Default	Unit	Data type
		0.167 - 5000	10	rps/s	DEC

In homing mode, after end-of-travel is reached, this sets the acceleration rate for seeking the homing switch. Refer to parameter P-91 (HA).

P-93 (HA)	Accel of feeding to homing switch during homing	Data Range	Default	Unit	Data type
		0.167 - 5000	10	rps/s	DEC

In homing mode, after the homing switch is reached it sets the acceleration rate for feed back to the homing switch. Refer to parameter P-91 (HA).

P-94 (HL)	Decel of seeking end-of-travel limit during homing	Data Range	Default	Unit	Data type
		0.167 - 5000	100	rps/s	DEC

In homing mode, this parameter sets the deceleration rate for seeking the end-of-travel limit. Refer to parameter P-91 (HA).

P-95 (HL)	Decel of seeking homing switch during homing	Data Range	Default	Unit	Data type
		0.167 - 5000	10	rps/s	DEC

In homing mode, after end-of-travel is reached, this sets the deceleration rate for seeking the homing switch. Refer to parameter P-91 (HA).

P-96 (HL)	Decel of feeding to homing switch during homing	Data Range	Default	Unit	Data type
		0.167 - 5000	10	rps/s	DEC

In homing mode, after the homing switch is reached it sets the deceleration rate for feed back to the homing switch. Refer to parameter P-91 (HA).

P-97 (HV)	Velocity of seeking end-of-travel limit during homing	Data Range	Default	Unit	Data type
		0.167 - 5000	100	rps/s	DEC

In homing mode, this parameter sets the velocity rate for seeking the end-of-travel limit. Refer to parameter P-91 (HA).

P-98 (HV)	Velocity of seeking homing switch during homing	Data Range	Default	Unit	Data type
		0.167 - 5000	10	rps/s	DEC

In homing mode, after end-of-travel is reached, this sets the velocity rate for seeking the homing switch. Refer to parameter P-91 (HA).

P-99 (HV)	Velocity of feeding to homing switch during homing	Data Range	Default	Unit	Data type
		0.167 - 5000	10	rps/s	DEC

In homing mode, after the homing switch is reached it sets the velocity rate for feed back to the homing switch. Refer to parameter P-91 (HA).

P-100 (KL)	Follow factor	Data Range	Default	Unit	Data type
		-32000 - +32000	0		DEC

Servo follow factor: Higher value will reduce system noise and eliminate the overshoot, but it will reduce the system dynamic following performance. Lower value will raise system stiffness, but may cause system noise.

P-101 (RD)	Select Motor Rotation	Data Range	Default	Unit	Data type
		0, 1	0		DEC

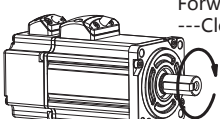
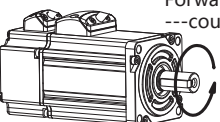
Motor Rotation	Value
	0
	1

9 Communication

M2DC series servo drives support multiple communication interfaces

Model type	Communication
-Q	RS-232
-R	RS-485
-C	CANopen
-IP	Ethernet
-D	

9.1 RS-232 communication

For Q type drives, port CN6 is the RJ-11 communication port for RS-232 communication. MOONS' SCL serial command language can be used to control the drive.

9.1.1 What is SCL?

MOONS' SCL, or Serial Command Language, was developed by to give users a simple way to control a motor drive via a serial port. This eliminates the need for separate motion controllers or to supply control signals, like Pulse & Direction, to step and servo motor drives. It also provides an easy way to interface to a variety of other industrial devices like PLCs, industrial computers, and HMIs, which often have standard or optional serial ports for communication.

NOTE: For more details about SCL commands, please download the Host Command Reference manual from MOONS' website.

9.1.2 RS-232 Connections

For servo drive port CN6, the RJ-11 pin definitions are as follows:

PIN	Definition
1, 3, 6	Not used
2	RX
4	TX
5	GND

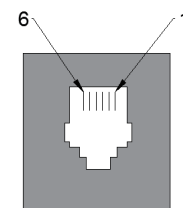

9.2 RS-485 Communication

R type drives use ports CN6 and CN7 with a standard RJ45 (8p8C) design. They can be used to build RS-485 daisy chain networks. In addition to the SCL command control methods, Modbus/RTU can also be used to control the drives.

9.2.1 RS-485 PIN definition

For RS-485 communication, the dual RJ45 connectors on the side of the drive can be used to build a daisy chain network system.

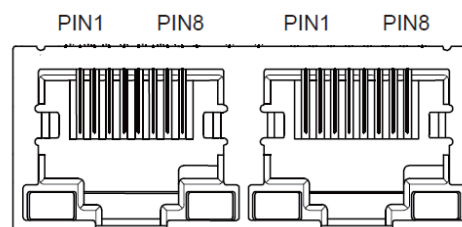

Pin definitions are as follows:

PIN	Definition
4, 5, 7, 8	GND
1	RX+
2	RX-
3	TX+
6	TX-

9.2.2 RS-485 Connection Method

RS-422/485 communication allows connection of more than one drive to a single host PC, PLC, HMI or other computer. It also allows the communication cable to be long. The use of Category 5 cable is recommended as it is widely used for computer networks, is inexpensive, easily obtained and certified for quality and data integrity.

The M2 drives can be used with either Two-Wire or Four-Wire RS-422/485 implementation. The connection can be point-to-point (i.e. one drive and one host) or a multi-drop network (one host and up to 32 drives).

Four-Wire Configuration

Four-wire systems utilize separate transmit and receive wires. One pair of wires must connect the host's transmit signals to each drive's RX+ and RX- terminals. The other pair connects the drive's TX+ and TX- terminals to the host's receive signals. A logic ground terminal is provided on each drive and can be used to keep all drives at the same ground potential. This terminal connects internally to the DC power supply return (V-), so if all the drives on the RS-422/485 network are powered from the same supply it is not necessary to connect the logic grounds. One drive's GND terminal should still be connected to the host computer ground.

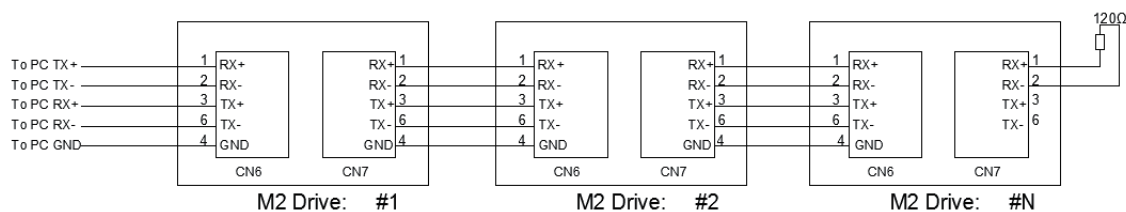

Two-Wire Configuration

In a 2-wire system, the host must disable its transmitter before it can receive data. This must be done quickly before a drive begins to answer a query. The M2 drives include a transmit delay parameter that can be adjusted to compensate for a host that is slow to disable its transmitter. This adjustment can be made over the network using the TD command, or it can be set using the M Servo Suite software. It is not necessary to set the transmit delay in a four wire system.

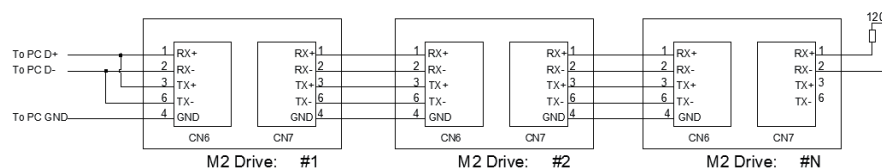

NOTE: For RJ45 crystal connector, we recommend standard CAT5 cables.

9.3 Modbus/RTU Communication

There are two types of communication methods for Modbus, ASCII (American Standard Code for information interchange), and RTU (Remote Terminal Unit). They are defined based on different bus modulation and demodulation methods. For M2DC series servo drives, only Modbus/RTU is supported.

9.3.1 Data Encoding

Big-endian: The most significant byte (MSB) value is stored at the memory location with the lowest address; the next byte value in significance is stored at the next memory location and so on. This is akin to Left-to-Right reading in hexadecimal order.

For example: To store a 32bit data 0x12345678 into register addresses 40031 and 40032, with 0x1234 defined as MSB, and 0x5678 as LSB, in big-endian system:

Register 40031 = 0x1234

Register 40032 = 0x5678

When transferring 0x12345678, the first word will be 0x1234, and the second word will be 0x5678.

Little-endian: The most significant byte (MSB) value is stored at the memory location with the highest address; the next byte value in significance is stored at the next memory location and so on. This is akin to Left-to-Right reading in hexadecimal order.

For example: To store a 32bit data 0x12345678 into register addresses 40031 and 40032, with 0x5678 defined as MSB, and 0x1234 as LSB, in little-endian system:

Register 40031 = 0x5678

Register 40032 = 0x1234

When transferring 0x12345678, the first word will be 0x5678, and the second word will be 0x1234.

The M2 drive parameter P-75 (PR) defines the data transfer type:

P-75 (PR) = 5 represents big-endian

P-75 (PR) = 133 represents little-endian

9.3.2 Communication Address

In the network system, each drive requires a unique drive address. Only the drive with the matching address will respond to the host command. In a Modbus network, address "0" is the broadcast address. It cannot be used for an individual drive's address. ModbusRTU/ASCII can set the drive address from 1 to 31.

9.3.3 Communication Baud Rate And Framing

M2DC series servo drives have fixed communication data framing: 8 data bits, one stop bit, no parity.

The drive parameter P-77 (BR) defines the communication baud rate.

In serial communication, the change of baudrate will NOT take effect immediately, it will ONLY take effect at the next power up of the drive.

1: 9600bps

2: 19200bps

3: 38400bps

4: 57600bps

5: 115200bps

9.3.4 Power Up Mode

Parameter P-14 (PM) sets the power up mode for the drive.

8: Modbus/RTU

9: Q mode with Modbus/RTU communication, stored Q program auto-executes at power-up.

9.3.5 Modbus/RTU Data Framing

Modbus/RTU is a master and slave communication system. The CRC checking code includes from drive's address bits to data bits. This standard data framing is as follows:



Based on data transfer status, there can be two types of response codes:

Normal Modbus response:

response function code = request function code

Modbus error response:

response function code = request function code + 0x80 (providing an error code)

9.3.6 M2DC series Servo Drive Register Addresses and Function List:

Register	Access	Data Type	Description	SCL Register
40001	Read Only	SHORT	Alarm Code (AL)	f
40002	Read Only	SHORT	Status Code (SC)	s
40003	Read Only	SHORT	Drive Digital output	
40004	Read Only	SHORT	Drive Digital output	i
40005..6	Read Only	LONG	Encoder Position (IE, EP)	e
40007..8	Read Only	LONG	Immediate Absolute Position(IP)	l
40009..10	Write	LONG	Absolute Position Command(SP)	P(Capital)
40011	Read Only	SHORT	Immediate Actual Velocity (IV0)	v
40012	Read Only	SHORT	Immediate Target Velocity (IV1)	w
40013	Read Only	SHORT	Immediate Drive Temperature (IT)	t
40014	Read Only	SHORT	Immediate Bus Voltage (IU)	u

Register	Access	Data Type	Description	SCL Register
40015..16	Read Only	LONG	Immediate Position Error (IX)	x
40017	Read Only	SHORT	Immediate Analog Input Value (IA)	a
40018	Read Only	SHORT	Q Program Line Number	b
40019	Read Only	SHORT	Immediate Current Command (IC)	c
40020..21	Read Only	LONG	Relative Distance (ID)	d
40022..23	Read Only	LONG	Sensor Position	g
40024	Read Only	SHORT	Condition Code	h
40025	Read Only	SHORT	Analog Input 1 (IA1)	j
40026	Read Only	SHORT	Analog Input 2 (IA2)	k
40027	Read Only	SHORT	Command Mode (CM)	m
40028	R/W	SHORT	Point-to-Point Acceleration (AC)	A
40029	R/W	SHORT	Point-to-Point Deceleration (DE)	B
40030	R/W	SHORT	Velocity (VE)	V
40031..32	R/W	LONG	Point-to-Point Distance (DI)	D
40033..34	R/W	LONG	Change Distance (DC)	C
40035	R/W	SHORT	Change Velocity (VC)	U
40036	Read Only	SHORT	Velocity Move State	n
40037	Read Only	SHORT	Point-to-Point Move State	o
40038	Read Only	SHORT	Q Program Segment Number	p
40039	Read Only	SHORT	Reserved	
40040	Read Only	SHORT	Phase Error	z
40041..42	R/W	LONG	Position Offset	E
40043	R/W	SHORT	Miscellaneous Flags	F
40044	R/W	SHORT	Current Command (GC)	G

Register	Access	Data Type	Description	SCL Register
40045..46	R/W	LONG	Input Counter	I
40047	R/W	SHORT	Jog Accel (JA)	
40048	R/W	SHORT	Jog Decel (JL)	
40049	R/W	SHORT	Jog Velocity (JS)	J
40050	R/W	SHORT	Max Velocity	
40051	R/W	SHORT	Continuous Current(CC)	N
40052	R/W	SHORT	Peak Current (CP)	O(Capital)
40053	Read Only	SHORT	Reserved	
40054..55	R/W	LONG	Pulse Counter	S
40056	R/W	SHORT	Analog Position Gain (AP)	X
40057	R/W	SHORT	Analog Threshold (AT)	Y
40058	R/W	SHORT	Analog Offset (AV)	Z
40059..60	R/W	LONG	Accumulator	0
40061..62	R/W	LONG	User Defined Register	1
40063..64	R/W	LONG	User Defined Register	2
40065..66	R/W	LONG	User Defined Register	3
40067..68	R/W	LONG	User Defined Register	4
40069..70	R/W	LONG	User Defined Register	5
40071..72	R/W	LONG	User Defined Register	6
40073..74	R/W	LONG	User Defined Register	7
40075..76	R/W	LONG	User Defined Register	8
40077..78	R/W	LONG	User Defined Register	9
40079..80	R/W	LONG	User Defined Register	:
40081..82	R/W	LONG	User Defined Register	;

Register	Access	Data Type	Description	SCL Register
40083..84	R/W	LONG	User Defined Register	<
40085..86	R/W	LONG	User Defined Register	=
40087..88	R/W	LONG	User Defined Register	>
40089..90	R/W	LONG	User Defined Register	?
40091..92	R/W	LONG	User Defined Register	@
40093..94	R/W	LONG	User Defined Register	[
40095..96	R/W	LONG	User Defined Register	\
40097..98	R/W	LONG	User Defined Register]
40099..100	R/W	LONG	User Defined Register	^
40101..102	R/W	LONG	User Defined Register	_
40103..104	R/W	LONG	User Defined Register	`
40105	R/W	SHORT	Brake Release Delay(BD)	
40106	R/W	SHORT	Brake Engage Delay(BE)	
40107	Read Only	SHORT	Reserved	
40108	Read Only	SHORT	Reserved	
40109	Read Only	SHORT	Firmware version	
40110	R/W	SHORT	Analog Filter Gain(AF)	
40111	Read Only	SHORT	Reserved	
40112	Read Only	SHORT	Alarm Code High bit	
40113	R/W	SHORT	Jog Change(JC)	
40114	R/W	SHORT	Jog Change(JC)	
40115	R/W	SHORT	Jog Change(JC)	
40116	R/W	SHORT	Jog Change(JC)	
40117	R/W	SHORT	Jog Change(JC)	

Register	Access	Data Type	Description	SCL Register
40118	R/W	SHORT	Jog Change(JC)	
40119	R/W	SHORT	Jog Change(JC)	
40120	R/W	SHORT	Jog Change(JC)	
40121	R/W	SHORT	X9 Input Filter	
40122	R/W	SHORT	X10 Input Filter	
40123	R/W	SHORT	X11 Input Filter	
40124	R/W	SHORT	X12 Input Filter	
40125	R/W	SHORT	Command Opcode	
40126	R/W	SHORT	Parameter 1	
40127	R/W	SHORT	Parameter 2	
40128	R/W	SHORT	Parameter 3	
40129	R/W	SHORT	Parameter 4	
40130	R/W	SHORT	Parameter 5	
40131	R/W	SHORT	Global Gain(KP)	
40132	R/W	SHORT	Global Gain1(KG)	
40133	R/W	SHORT	Proportional Gain(KF)	
40134	R/W	SHORT	Damping Gain(KD)	
40135	R/W	SHORT	Velocity Gain(KV)	
40136	R/W	SHORT	Integral Gain(KI)	
40137	R/W	SHORT	Inertia Feed forward Gain(KK)	
40138	R/W	SHORT	Jerk Filter(KJ)	
40139	R/W	SHORT	Velocity Mode Proportional Gain(VP)	
40140	R/W	SHORT	Velocity Mode Integral Gain(VI)	
40141	R/W	SHORT	Damping Filter Gain(KE)	
40142	R/W	SHORT	Current Filter Gain(KC)	

Register	Access	Data Type	Description	SCL Register
40143	R/W	SHORT	Control Mode(CM)	
40144	R/W	SHORT	Control Mode 1(CN)	
40145	R/W	SHORT	Operation Mode(PM)	
40146	R/W	SHORT	Jog Mode(JM)	
40147	R/W	SHORT	Hard-Stop Current Limit(HC)	
40148	R/W	SHORT	Max Acceleration(AM)	
40149	Read Only	SHORT	Encoder Resolution(ER)	
40150	Read Only	SHORT	Reserved	
40151	Read Only	SHORT	Steps-Rev(EG)	
40152	R/W	SHORT	Electronic Ration Numerator(EN)	
40153	R/W	SHORT	Electronic Ration Denominator(ED)	
40154	Read Only	SHORT	Step Mode (SZ)	
40155	R/W	SHORT	Position Fault(PF)	
40156	R/W	SHORT	Dynamic Position Error Count(PL)	
40157	R/W	SHORT	In-Position Counts(PD)	
40158	R/W	SHORT	In-Position Timing(PE)	
40159	R/W	SHORT	Pulse Complete Timing(TT)	
40160	R/W	SHORT	Analog Velocity Gain(AG)	
40161	R/W	SHORT	Analog Torque Gain(AN)	
40162	R/W	SHORT	Analog Offset 1(AV1)	
40163	R/W	SHORT	Analog Offset 2(AV2)	
40164	R/W	SHORT	Analog Type(AS)	
40165	R/W	SHORT	Analog Deadband 1(AD1)	

Register	Access	Data Type	Description	SCL Register
40166	R/W	SHORT	Analog Deadband 2(AD2)	
40167	R/W	SHORT	Analog Deadband (AD)	
40168	R/W	SHORT	Analog Function(FA)	
40169	R/W	SHORT	Servo Enable(SI)	
40170	R/W	SHORT	Alarm Reset(AI)	
40171	R/W	SHORT	Define Limits Input(DL)	
40172	R/W	SHORT	Motion Input	
40173	R/W	SHORT	Alarm Output(AO)	
40174	R/W	SHORT	Brake Output(BO)	
40175	R/W	SHORT	Motion Output(MO)	
40176	R/W	SHORT	Reserved	
40177	R/W	SHORT	Communication Protocol(PR)	
40178	R/W	SHORT	Transmit Delay(TD)	
40179	R/W	SHORT	Baud Rate(BR)	
40180	R/W	SHORT	Communication Address(DA)	
40181	R/W	SHORT	Velocity value(VR)	
40182	R/W	SHORT	Tach-out Count(TO)	
40183	R/W	SHORT	Torque Value(TV)	
40184	R/W	SHORT	Parameters Lock(PK)	
40185	R/W	SHORT	Default Display(DD)	
40186	R/W	SHORT	Mask Alarm(MA)	
40187	R/W	SHORT	Homing Acceleration 1	
40188	R/W	SHORT	Homing Acceleration 2	
40189	R/W	SHORT	Homing Acceleration 3	

Register	Access	Data Type	Description	SCL Register
40190	R/W	SHORT	Homing Deceleration 1	
40191	R/W	SHORT	Homing Deceleration 2	
40192	R/W	SHORT	Homing Deceleration 3	
40193	R/W	SHORT	Homing Velocity 1	
40194	R/W	SHORT	Homing Velocity 2	
40195	R/W	SHORT	Homing Velocity 3	
40196	R/W	SHORT	Clamp Resistance(ZR)	
40197	R/W	SHORT	Clamp Count (ZC)	
40198	R/W	SHORT	Clamp time(ZT)	
40199	Read Only	SHORT	Reserved	
40200	Read Only	SHORT	Reserved	

9.3.7 Command Opcode Description

Register 40125 is defined as Command Opcode, when the following commands are entered into the register, the drive will execute the corresponding operation.

1) SCL Command Encoding Table

SCL Command Encoding Table							
Function	SCL	Opcode	Parameter 1	Parameter 2	Parameter 3	Parameter 4	Parameter 5
Alarm Reset	AX	0xBA	x	x	x	x	x
Start Jogging	CJ	0x96	x	x	x	x	x
Stop Jogging	SJ	0xD8	x	x	x	x	x
Encoder Function	EF	0xD6	0,1,2 or 6	x	x	x	x
Encoder Position	EP	0x98	Position	x	x	x	x
Feed to Double Sensor	FD	0x69	I/O Point 1	Condition 1	I/O Point 2	Condition 2	x
Follow Encoder	FE	0xCC	I/O Point	Condition	x	x	x
Feed to Length	FL	0x66	x	x	x	x	x
Feed to Sensor with Mask Distance	FM	0x6A	I/O Point	Condition	x	x	x
Feed and Set Output	FO	0x68	I/O Point	Condition	x	x	x
Feed to Position	FP	0x67	x	x	x	x	x
Feed to Sensor	FS	0x6B	I/O Point	Condition	x	x	x
Feed to Sensor with Safety Distance	FY	0x6C	I/O Point	Condition	x	x	x
Jog Disable	JD	0xA3	x	x	x	x	x
Jog Enable	JE	0xA2	x	x	x	x	x
Motor Disable	MD	0x9E	x	x	x	x	x
Motor Enable	ME	0x9F	x	x	x	x	x
Seek Home	SH	0x6E	I/O Point	Condition	x	x	x
Set Position	SP	0xA5	Position	x	x	x	x
Filter Input	FI	0xC0	I/O Point	Filter Time	x	x	x
Filter Select Inputs	FX	0xD3	x	x	x	x	x
Step Filter Freq	SF	0x06	Freq	x	x	x	x
Analog Deadband	AD	0xD2	0.001 V	x	x	x	x
Alarm Reset Input	AI	0x46	Function ('1'..'3')	I/O Point	x	x	x
Alarm Output	AO	0x47	Function ('1'..'3')	I/O Point	x	x	x
Analog Scaling	AS	0xD1	x	x	x	x	x
Define Limits	DL	0x42	1..3	x	x	x	x
Set Output	SO	0x8B	I/O Point	Condition	x	x	x
Wait for Input	WI	0x70	x	x	x	x	x
Queue Load & Execute	QX	0x78	1..12	x	x	x	x
Wait Time	WT	0x6F	0.01 sec	x	x	x	x
Stop Move, Kill Buffer	SK	0xE1	x	x	x	x	x
Stop Move, Kill Buffer	SKD	0xE2	x	x	x	x	x

For more detailed command functions description, please refer to the **Host Command Reference manual**.

2) Digital I/O Function Selection And I/O Status

Character	hex code	
'0'	0x30	Index of encode
'1'	0x31	input 1 or output 1
'2'	0x32	input 2 or output 2
'3'	0x33	input 3 or output 3
'4'	0x34	input 4 or output 4
'5'	0x35	input 5 or output 5
'6'	0x36	input 6 or output 6
'7'	0x37	input 7
'8'	0x38	input 8
'9'	0x39	input 9
':'	0x3A	input 10
','	0x3B	input 11
'<'	0x3C	input 12
'L'	0x4C	low state (closed)
'H'	0x48	high state (open)
'R'	0x52	rising edge
'F'	0x46	falling edge

9.3.8 Function Code

MOONS' drives currently support the following Modbus function codes:

- 1) 0x03: Read holding registers
- 2) 0x04: Read input registers
- 3) 0x06: Write single registers
- 4) 0x10: Write multiple registers

9.3.8.1 Function Code 0X03, Reading Multiple Holding Registers

To read the encoder's actual position command to drive Node ID 1, the data address for the encoder's actual position is register 40005. If the register value is in decimal numbers it will be 2,500,000, and the transfer method is P-75 (PR) = 5, for big-endian transfer.

Communication details are as follows:

Command Message (Master)			Response Message (slave)		
Function	Data	Number Of Bytes	Function	Data	Number Of Bytes
Slave Address	01H	1	Slave Address	01H	1
Function Code	03H	1	Function Code	03H	1
Starting Data Address	00H (High) 04H (Low)	2	Number of Data (In Byte)	04	1
Number of Data (In word)	00 (High) 02 (Low)	2	Content of Starting Data Address 40005	00H (High) 26H (Low)	2
CRC Check Low	85	1	Content of second Data Address 40006	25H (High) A0 (Low)	2
CRC Check High	CA	1	CRC Check Low	01H	1
			CRC Check High	10H	1

Host Sending: 01 03 00 04 00 02 85 CA

Drive Reply: 01 03 04 00 26 25 A0 01 10

If an error occurs, drive reply format will be: 01 83 XX CRC_L CRC_H

When XX = 01 Function code 03 unsupported

XX = 02 Incorrect reading of drive's address or numbers

XX = 03 Reading register address out of range

XX = 04 Reading failure

9.3.8.2 Function Code 0x06, Writing Single Register

To set the motor rotary velocity 12.5 rps to drive Node ID 11, the corresponding register address is 40030. The write-in data value for the register will be $12.5 \times 240 = 3000$. In hexadecimal, it is 12CH.

Communication Details are as follows:

Command Message (Master)			Response Message (slave)		
function	data	number of bytes	function	data	number of bytes
Slave Address	0BH	1	Slave Address	0BH	1
Function Code	06H	1	Function Code	06H	1
Starting Data Address	00H (High) 1DH (Low)	2	Starting Data Address	00H (High) 1DH (Low)	2
Content of Data	01 (High) 2C (Low)	2	Content of Data	01 (High) 2C (Low)	2
CRC Check Low	19	1	CRC Check Low	19	1
CRC Check High	2B	1	CRC Check High	2B	1

Host Sending: 0B 06 00 1D 01 2C 19 2B

Drive Reply: 0B 06 00 1D 01 2C 19 2B

If an error occurs, drive reply format will be: 01 86 XX CRC_L CRC_H

When XX = 01 Function code 06 unsupported

XX = 02 Incorrect writing on driving address or number

XX = 03 Writing register address out of range

XX = 04 Writing failure

9.3.8.3 Function Code 0X10, Writing Multiple Registers

To write target distance 30000 into drive Node ID 10, the corresponding register address is 40031. Transferred into hexadecimal, it is 7530h.

Communication Details are as follows:

Command Message (Master)			Response Message (slave)		
Function	Data	Number Of Bytes	Function	Data	Number Of Bytes
Slave Address	0AH	1	Slave Address	0AH	1
Function Code	10H	1	Function Code	10H	1
Starting Data Address	00H (High) 1EH (Low)	2	Starting Data Address	00H (High) 1EH (Low)	2
Number of Data (In word)	00H (High) 02H (Low)	2	Number of Data (In word)	00H (High) 02H (Low)	2
Number of Data (In byte)	04H	1	CRC Check Low	20	1
Content of first Data address	00 (High) 00 (Low)	2	CRC Check High	B5	1
Content of second Data address	75H (High) 30H (Low)	2			
CRC Check Low	70	1			
CRC Check High	8F	1			

Host Sending: 0A 10 00 1E 00 02 04 00 75 30 70 8F

Drive Reply: 0A 10 00 1E 00 02 20 B5

If an error is occurs, drive reply format will be: 01 90 XX CRC_L CRC_H

Where XX = 01 Function code 10 unsupported

XX = 02 Incorrect reading on driving address or number

XX = 03 Reading register address out of range

XX = 04 Reading failure

9.3.9 Modbus/RTU Applications

9.3.9.1 Position Control

Target Profile Planning

SCL command	Target Value	Unit	Dec	Dec (Hex)	Description
AC	100	rps/s	40028	600 (258h)	The unit for register 40028 is $\frac{1}{6}rps^2$, when target acceleration is 100rps/s, the value will be 600
DE	200	rps/s	40029	1200 (4B0h)	The unit for register 40029 is $\frac{1}{6}rps^2$. When target deceleration is 200 rps/s, the value will be 1200
VE	10	rps	40030	2400 (960h)	The unit for register 40030 is $\frac{1}{240}rps$. When target velocity is 10 rps/s, the value will be 2400
DI	20000	counts	40031~40032	20000 (4E20h)	The target distance will be 20000 counts

Drive Setting

Parameter	Function
P-75 (PR) = 5	Big-endian data transfer
P-76 (TD) = 10	feedback delay 10ms
P-77 (BR) = 3	communication baud rate 38400bps
P-78 (DA) = 1	Communication address 1
P-14 (PM) = 8	Power up mode as Modbus/RTU

Use M Servo Suite software for configuration:

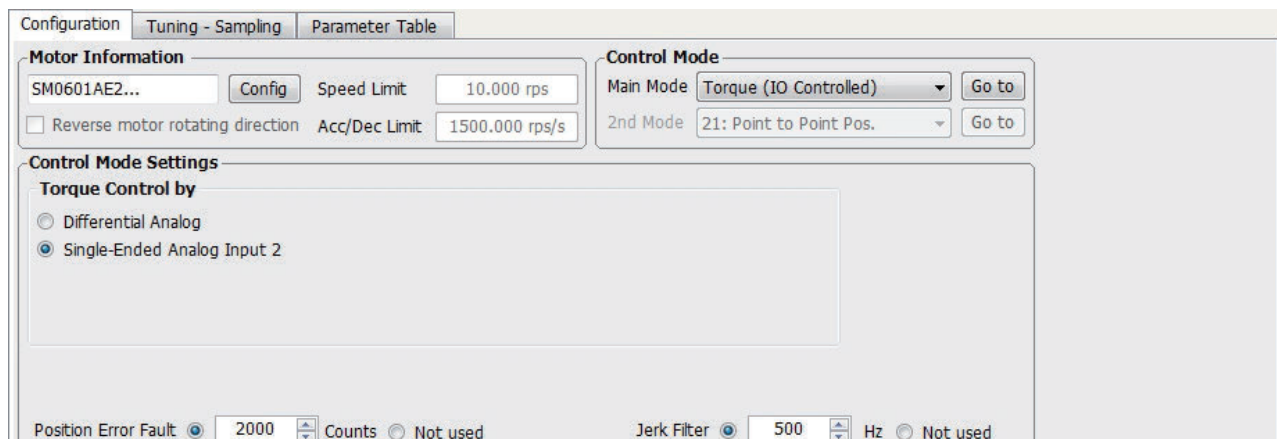

Sending Command

Set acceleration register 40028 = 285h

deceleration register 40029 = 4B0h

velocity register 40030 = 960h

target position 40031 - 40032 = 4E20h

Host Sending: 01 10 00 1B 00 05 0A 02 58 04 B0 09 60 00 00 4E 20 24 3B

Drive Response: 01 10 00 1B 00 05 70 0D

Command Message (Master)			Command Message (Slave)		
Function	Data	Number Of Bytes	Function	Data	Number Of Bytes
Slave Address	01H	1	Slave Address	01H	1
Function Code	10H	1	Function Code	10H	1
Starting Data Address	00H (High) 1BH (Low)	2	Starting Data Address	00H (High) 1BH (Low)	2
Number of Data (In word)	00H (High) 05H (Low)	2	Number of Data (In word)	00H (High) 05H (Low)	2
Number of Data (In word)	0AH	1	CRC Check Low	70	1
Content of first Data address 40028	02 (High) 58 (Low)	2	CRC Check High	0D	1
Content of second Data address 40029	04H (High) B0H (Low)	2			
Content of third Data address 40030	09H (High) 60H (Low)	2			
Content of fourth Data address 40031	00H (High) 00H (Low)	2			
Content of fifth Data address 40032	4EH (High) 20H (Low)	2			
CRC Check Low	24	1			
CRC Check High	3B	1			

Point To Point Motion Command

Section 9.3.7 Command Opcode describes register 40125's control code. The SCL code list shows that for point-to-point position motion, data 0x66 must be written to register 40125.

SCL Command Encoding Table							
Function	SCL	Opcode	Parameter 1	Parameter 2	Parameter 3	Parameter 4	Parameter 5
Feed to Length	FL	0x66	x	x	x	x	x

Host Sending: 01 06 00 7C 00 66 C8 38

Drive Reply: 01 06 00 7C 00 66 C8 38

Command Message (Master)			Command Message (Slave)		
Function	Data	Number Of Bytes	Function	Data	Number Of Bytes
Slave Address	01H	1	Slave Address	01H	1
Function Code	06H	1	Function Code	06H	1
Starting Data Address	00H (High) 7CH (Low)	2	Starting Data Address	00H (High) 7CH (Low)	2
Content of Data	00 (High) 66 (Low)	2	Content of Data	00 (High) 66 (Low)	2
CRC Check Low	C8	1	CRC Check Low	C8	1
CRC Check High	38	1	CRC Check High	38	1

9.3.9.2 JOG mode

JOG mode required parameters:

SCL command	Target Value	Unit	Dec	Dec (Hex)	Description
AC	100	rps/s	40047	600 (258h)	The unit for register 40028 is $\frac{1}{6}rps^2$, when target acceleration is 100rps/s, the value will be 600
JL	200	rps/s	40048	1200 (258h)	The unit for register 40029 is $\frac{1}{6}rps^2$. When target deceleration is 200rps/s, the value will be 1200
JS	10	rps	40049	2400 (960)	The unit for register 40030 is $\frac{1}{240}rps$. When target velocity is 200rps/s, the value will be 1200

Drive Setting

Parameter	Function
P-75 (PR) = 5	Big-endian data transfer
P-76 (TD) = 10	Feedback delay 10ms
P-77 (BR) = 3	Communication baud rate 38400bps
P-78 (DA) = 1	Communication address 1
P-14 (PM) = 8	Power up mode as modbus/rtu

Use M Servo Suite software for configuration:

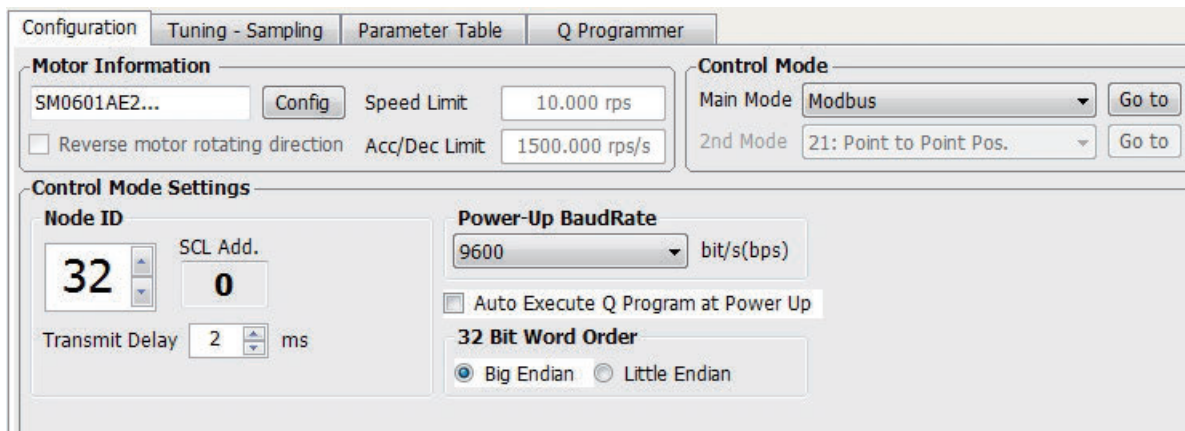

Sending Command

Set velocity mode acceleration register as 40047 = 258h

deceleration register as 40048 = 4B0h

velocity register 40049 = 960h

Host Sending: 01 10 00 2E 00 03 06 02 58 04 B0 09 60 A0 9F

Drive Reply: 01 10 00 2E 00 03 E0 01

Command Message (Master)			Command Message (Slave)		
Function	Data	Number Of Bytes	Function	Data	Number Of Bytes
Slave Address	01H	1	Slave Address	01H	1
Function Code	10H	1	Function Code	10H	1
Starting Data Address	00H (High) 2EH (Low)	2	Starting Data Address	00H (High) 2EH (Low)	2
Number of Data (In word)	00H (High) 03H (Low)	2	Number of Data (In word)	00H (High) 03H (Low)	2
Number of Data (In word)	06H	1	CRC Check Low	70	1
Content of first Data address 40047	02 (High) 58 (Low)	2	CRC Check High	0D	1
Content of second Data address 40048	04H (High) B0H (Low)	2			
Content of third Data address 40049	09H (High) 60H (Low)	2			
CRC Check Low	A0	1			
CRC Check High	9F	1			

Command for Executing Point-To-Point Motion

Section 9.3.7 command Opcode describes register 40125's control code. The SCL code list shows that for JOG mode, data 0x66 must be written to register 40125 to start, and 0xD8 sent to register 40125 to stop.

SCL Command Encoding Table							
Function	SCL	Opcode	Parameter 1	Parameter 2	Parameter 3	Parameter 4	Parameter 5
Start Jogging	CJ	0x96	x	x	x	x	x
Stop Jogging	SJ	0xD8	x	x	x	x	x

Start

Host Sending: 01 06 00 7C 00 96 C8 7C

Drive Reply: 01 06 00 7C 00 96 C8 7C

Stop

Host Sending: 01 06 00 7C 00 D8 48 48

Drive Reply: 01 06 00 7C 00 D8 48 48

Starting message :

Command Message (Master)			Command Message (Slave)		
Function	Data	Number Of Bytes	Function	Data	Number Of Bytes
Slave Address	01H	1	Slave Address	01H	1
Function Code	06H	1	Function Code	06H	1
Starting Data Address	00H (High) 7CH (Low)	2	Starting Data Address	00H (High) 7CH (Low)	2
Content of Data	00 (High) 96 (Low)	2	Content of Data	00 (High) 96 (Low)	2
CRC Check Low	C8	1	CRC Check Low	C8	1
CRC Check High	7C	1	CRC Check High	7C	1

Stopping Message:

Command Message (Master)			Command Message (Slave)		
Function	Data	Number Of Bytes	Function	Data	Number Of Bytes
Slave Address	01H	1	Slave Address	01H	1
Function Code	06H	1	Function Code	06H	1
Starting Data Address	00H (High) 7CH (Low)	2	Starting Data Address	00H (High) 7CH (Low)	2
Content of Data	00 (High) D8 (Low)	2	Content of Data	00 (High) D8 (Low)	2
CRC Check Low	48	1	CRC Check Low	48	1
CRC Check High	48	1	CRC Check High	48	1

Connect to Drive	Signal	Color	Connect to Motor
(JST) S06B-F32SK-GGXR			AMP 172159-1
4	U	Red	1
5	V	Yellow	2
6	W	Blue	3
Ground	PE	Yellow /Green	4

9.4 CANopen Communication

For C type drives, ports CN6 and CN7 are a standard RJ45 (8p8c) design, can be used to build a daisy chain network using CAT cables.

9.4.1 RJ45 (8p8c) Pin Definitions

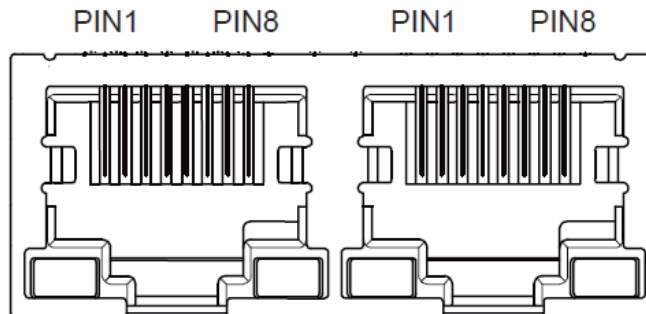

PIN	Definition
1	CAN_H
2	CAN_L
3, 7	GND
6	CHGND
4, 5, 8	

9.4.2 CANopen NODE-ID

In the CANopen network, each drive needs to have a unique NODE-ID. For M2DC series servo drives, NODE-IDs can be set from 1-112. "0" cannot be used for ID setting.

Parameter P-79 (CO) sets the NODE-ID.

9.4.3 CANopen Communication Baud Rate

Parameter P-80 (CB) sets the CANopen communication baud rate. For CANopen drives, it supports 8 levels of communication baud rate.

Setting value	communication baud rate	Setting value	communication baud rate
0	1M	4	125K
1	800K	5	50K
2	500K	6	25K
3	250K	7	12.5K

For more details, please refer to the CANopen User Manual.

10 Trouble Shooting

10.1 Drive Alarm List

LED display	Description	Alarm type	Drive status after alarm occurs
r01ot	Drive over temperature	Fault	Servo off
r02ur	Internal voltage fault	Fault	Servo off
r03uH	Over voltage	Fault	Servo off
r04HC	Over current	Fault	Servo off
r05LC		Fault	Servo off
r06rC		Fault	Servo off
r08Hb	Bad hall sensor	Fault	Servo off
r09Eb	Encoder error	Fault	Servo off
r10PL	Position error	Fault	Servo off
r11Lu	Low voltage	Fault	Servo off
r12ou	Velocity limited	Warning	No change to drive's status
r13Lt	CW limit or CCW limit activated	Warning	No change to drive's status
r14LL	CW limit is activated	Warning	No change to drive's status
r15JL	CCW limit is activated	Warning	No change to drive's status
r16CL	Current limit	Warning	No change to drive's status
r17CE	Communication error	Warning	No change to drive's status
r18EF	Parameter save failed	Warning	No change to drive's status
r20to	STO is activated	Warning	Servo off
r21rF	Regeneration failed	Warning	No change to drive's status
r22uH	Low voltage	Warning	No change to drive's status
r239E	Q program is empty	Warning	No change to drive's status
r24dd	Move when the drive is disabled.	Warning	No change to drive's status

10.2 Drive alarm causes and solutions

LED display	Description	Alarm type	Processing method
r01ot	Drive over temperature	Temperature of the heat sink or power device has been risen over the specified temperature. 1. Ambient temperature has risen over the specified temperature. 2. Over-load	1. Improve the ambient temperature and cooling condition. 2. Increase the capacity of the driver and motor. Set up longer acceleration/deceleration time. Lower the load
r02ur	Internal voltage fault	Drive internal voltage failure.	1. Please check supply power voltage 2. Please replace the drive with a new one, and contact MOONS'
r03uH	Over voltage	Drive DC bus voltage is too high M2DC series : Higher than 90VDC 1. Power supply voltage has exceeded the permissible input voltage. 2. Disconnection of the regeneration discharge resistor 3. External regeneration discharge resistor is not appropriate and could not absorb the regeneration energy. 4. Failure	1. Enter correct voltage. 2. Measure the resistance of the internal regeneration resistor. 3. please measure the external resistor, Replace the external resistor if the value is ∞. 4. Please contact MOONS' or replace the driver with a new one.
r04HC r05LC r06rC	Over current	1. Failure of servo driver (failure of the circuit, IGBT or other components) 2. Short of the motor wire (U, V and W) 3. Burnout of the motor 4. Poor contact of the motor wire. 5. Input pulse frequency is too high. 6. Motor is over load, command output torque is larger than maximum torque, for a long operating time. 7. Poor gain adjustment cause motor vibration, and abnormal noise. 8. Machine has collided or the load has gotten heavy. Machine has been distorted. 9. Welding of contact of dynamic braking relay due to frequent servo ON/OFF operations.	1. Turn to Servo-ON, while disconnecting the motor. If error occurs immediately, replace with a new driver. 2. Check that the motor wire (U, V and W) is not shorted, and check the branched out wire out of the connector. Make a correct wiring connection. 3. Measure the insulation resistance between motor wires, U, V and W and earth wire. In case of poor insulation, replace the motor. 4. Check the balance of resistor between each motor line, and if unbalance is found, replace the motor. 5. Check the loose connectors. If they are, or pulled out, fix them securely. 6. Adjust gain value settings. 7. Measuring brake voltage 8. Check drive and motor encoder and power wires. 9. please contact MOONS'.
r08Hb	Bad hall sensor	Hall sensor fault	1. please check encoder connection 2. please check your drive motor configurations.
r09Eb	Encoder error	Encoder signal fault	please check encoder connection.
r10PL	Position error	Position error value exceeds the position error range set by parameter P-44 (PF).	1. Please check parameter P-44 (PF). 2. Please check drive gain value settings. 3. Please check the load factor of the regeneration resistor, increase the capacity of the driver and the motor, and loosen the deceleration time
r11Lu	Low voltage	1. Power supply voltage is lower than 12VDC. Instantaneous power failure has occurred 2. Lack of power capacity...Power supply voltage has fallen down due to inrush current at the main power-on. 3. Failure of servo driver (failure of the circuit)	1. Increase the power capacity. Change the power supply. 2. please check power input connections . Please refer to 4.1.4 drive power connection 3. please contact MOONS'

r12ou	Position error	Motor rotary velocity exceeds parameter P-20(VM) setting value.	Please check motor velocity command if it is within the P-20(VM) range. 1. Avoid high velocity command 2. Check the command pulse input frequency and division/multiplication ratio. 3. Make a gain adjustment when an overshoot has occurred due to a poor gain adjustment. 4. Make a wiring connection of the encoder as per the wiring diagram.
r13Lt	CW limit or CCW limit activated	CW and CCW limit is ON	1. External limit switch is triggered. 2. Check x5 and x6 limit settings, please refer to chapter7.1.3 Cw/ccw limit.
r14LL	CW limit is activated	CCW limit triggered	1. External limit switch is triggered. 2. Check x5 and x6 limit settings.
r15JL	CCW limit is activated	CW limit triggered	
r16CL	Current limit	Driver's output current exceeds setting value P-19 (CP) 1. Load was heavy and actual torque has exceeded the rated torque and kept running for a long time. 2. Oscillation and hunching action due to poor gain adjustment. Motor vibration, abnormal noise. 3. Machine has collided or the load has gotten heavy. Machine has been distorted.	1. Make a gain re-adjustment. 2. Increase the capacity of the driver and motor. Set up longer acceleration/deceleration time. Lower the load. 3. Check motor wirings for U/V/W as red/yellow/blue.
r17CE	Communication error	Drive and host communication error.	Please check wiring connection, and drive's communication address and baud rate setting.
r18EF	Parameter save failed	Saving parameter failure.	1. Please try to save again. 2. if problems is not solved, please contact MOONS'
r20to	STO is activated	Safety torque off function is activated. Either or both safety input 1 or 2 is ON.	Please confirm safety input 1 and 2 wiring configuration. Please check Safety sensor setting.
r21rF	Regeneration failed	Regenerative energy has exceeded the capacity of regenerative resistor. 1. Due to the regenerative energy during deceleration caused by a large load inertia, converter voltage has risen, and the voltage is risen further due to the lack of capacity of absorbing this energy of the regeneration discharge resistor. 2. Regenerative energy has not been absorbed in the specified time due to a high motor rotational speed.	1. Internal resistor value is smaller than required, cannot absorb the regeneration energy. 2. Please check external regeneration resistor connections. 3. Reduce rotary velocity and decrease acceleration and deceleration value.
r22uH	Voltage Warning	Drive voltage lower than 16VDC 1) Power supply voltage is low. Instantaneous power failure has occurred 2) Lack of power capacity...Power supply voltage has fallen down due to inrush current at the main power-on. 3) Failure of servo driver (failure of the circuit)	1) Increase the power capacity. Change the power supply. 2) Please check power connections, please refer to 3.1.4 P1 drive power connection. 3) please contact MOONS'.
r239E	Q program is empty	Drive in Q mode, but Q program is empty.	1. Please check Q program. 2. Please check operation mode correction. 3. Please check Q program coding, make sure no faults to stop the program running.
r24dd	Move when the drive is disabled.	Motion command is received while motor is disabled.	Please enable the motor, and send the command again.

Appendix

Appendix 1: LED Character Reference

1	2	3	4	5	6	7	8	9	0
1	2	3	4	5	6	7	8	9	10
A	b	C	d	E	F	G	H	I	J
A	B	C	D	E	F	G	H	I	J
K	L	M	N	O	P	Q	R	S	T
K	L	M	N	O	P	Q	R	S	T
U	v	8	4	y	2				
U	V	W	X	Y	Z				

Appendix 2: Cables and Connectors

Listed below are cables and connectors available from MOONS' to make implementation of an M2DC servo system fast and easy.

Encoder Cables

See Section 4.3 for more information on wiring the connectors.

Motor Power Cables

See Section 4.2 for more information on wiring the connectors.

Encoder Cables

Standard Type

P/N	Description
2627-100	M2 Common Encoder Cable, Shielded, 1m
2627-300	M2 Common Encoder Cable, Shielded, 3m
2627-500	M2 Common Encoder Cable, Shielded, 5m
2627-1000	M2 Common Encoder Cable, Shielded, 10m

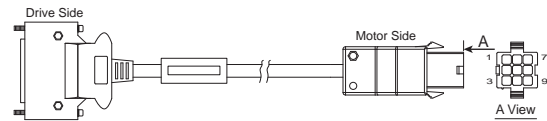

Flexible Encoder Cable - Extra Type

P/N	Description
2621-100	M2 Flexible Encoder Cable, 1m
2621-300	M2 Flexible Encoder Cable, 3m
2621-500	M2 Flexible Encoder Cable, 5m
2621-1000	M2 Flexible Encoder Cable, 10m

*: Min. band radius: 100mm; Travel distance: 600mm; Lifetime: 5,000,000c

Connect to drive	Signal	Colour	Connect to Motor
TYCO 3-2232346-1			AMP 172161-1
1	A+/U+	Blue	1
2	B+/V+	Green	2
3	Z+/W+	Yellow	3
14	A-/U-	Blue/Black	4
15	B-/V-	Green/Black	5
16	Z-/W-	Yellow/Black	6
11	+5V	Red	7
24	GND	Black	8
26	Shield	Shield	9

Motor Power Cable—M2DC-6D0

Standard Type

P/N	Description
1630-100	M2DC-6D0 Common Motor Cable, 1m
1630-300	M2DC-6D0 Common Motor Cable, 3m
1630-500	M2DC-6D0 Common Motor Cable, 5m
1630-1000	M2DC-6D0 Common Motor Cable, 10m

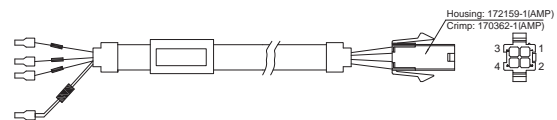

Flexible Motor Cable - Extra Type

P/N	Description
1631-100	M2DC-6D0 Flexible Motor Cable, extra type, Shielded, 1m
1631-300	M2DC-6D0 Flexible Motor Cable, extra type, Shielded, 3m
1631-500	M2DC-6D0 Flexible Motor Cable, extra type, Shielded, 5m
1631-1000	M2DC-6D0 Flexible Motor Cable, extra type, Shielded, 10m

*: Min. band radius: 100mm; Travel distance: 600mm; Lifetime: 5,000,000c

Connect to drive	Signal	Colour	Connect to Motor
5452571(Phoenix)			AMP 172159-1
U	U	Red	1
V	V	Yellow	2
W	W	Blue	3
⊕	PE	Yellow/Green	4

Motor Power Cable—M2DC-10D

Standard Type

P/N	Description
1627-100	M2DC-10D Common Motor Cable, Shielded, 1m
1627-300	M2DC-10D Common Motor Cable, Shielded, 3m
1627-500	M2DC-10D Common Motor Cable, Shielded, 5m
1627-1000	M2DC-10D Common Motor Cable, Shielded, 10m

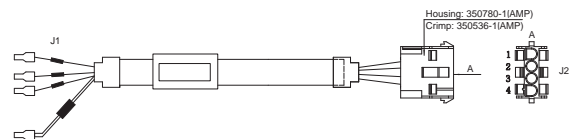

Flexible Motor Cable - Extra Type

P/N	Description
1628-100	M2DC-10D Flexible Motor Cable, extra type, Shielded, 1m
1628-300	M2DC-10D Flexible Motor Cable, extra type, Shielded, 3m
1628-500	M2DC-10D Flexible Motor Cable, extra type, Shielded, 5m
1628-1000	M2DC-10D Flexible Motor Cable, extra type, Shielded, 10m

*: Min. band radius: 100mm; Travel distance: 600mm; Lifetime: 5,000,000c

Connect to drive	Signal	Colour	Connect to Motor
5452571(Phoenix)			AMP 350780-1
U	U	Red	1
V	V	Yellow	2
W	W	Blue	3
⊕	PE	Yellow/Green	4

Motor Power Cable—M2DC-20D

Standard Type

P/N	Description
1641-100	M2DC-20D Common Motor Cable, Shielded, 1m
1641-300	M2DC-20D Common Motor Cable, Shielded, 3m
1641-500	M2DC-20D Common Motor Cable, Shielded, 5m

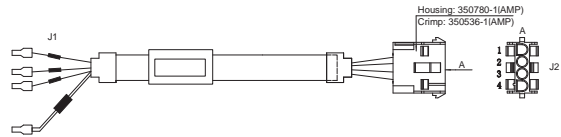

Flexible Motor Cable - Extra Type

P/N	Description
1642-100	M2DC-20D Flexible Motor Cable, extra type, Shielded, 1m
1642-300	M2DC-20D Flexible Motor Cable, extra type, Shielded, 3m
1642-500	M2DC-20D Flexible Motor Cable, extra type, Shielded, 5m

Connect to drive	Signal	Colour	Connect to Motor
5452571 (Phoenix)			AMP 350780-1
U	U	Red	1
V	V	Yellow	2
⊕	PE	Yellow/Green	4

*: Min. band radius: 100mm; Travel distance: 600mm; Lifetime: 5,000,000c

Motor Brake Cable

P/N	Description
1602-100	M2 Motor Brake Cable, 1m
1602-300	M2 Motor Brake Cable, 3m
1602-500	M2 Motor Brake Cable, 5m
1602-1000	M2 Motor Brake Cable, 10m

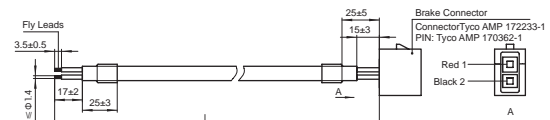

P/N	Description
1602-100-C05	M2 Flexible Motor Brake cable, 1m
1602-300-C05	M2 Flexible Motor Brake cable, 3m
1602-500-C05	M2 Flexible Motor Brake cable, 5m
1602-1000-C05	M2 Flexible Motor Brake cable, 10m

USB mini-B Configuration Cable

Description	P/N	Num.	Manufacturer	Details
USB mini-B Configuration Cable	2620-150	1	MOONS'	For connector CN1

CN6\CN7 RS-485\CANopen Daisy Chain Cable

P/N	Description
2012-030	Common type, Twisted-pair, 0.3m
2012-300	Common type, Twisted-pair, 3m
2013-030	Shielded type, Twisted-pair, 0.3m
2013-300	Shielded type, Twisted-pair, 3m

