

■ RV050

Weight without motor ≈ 3.5kg

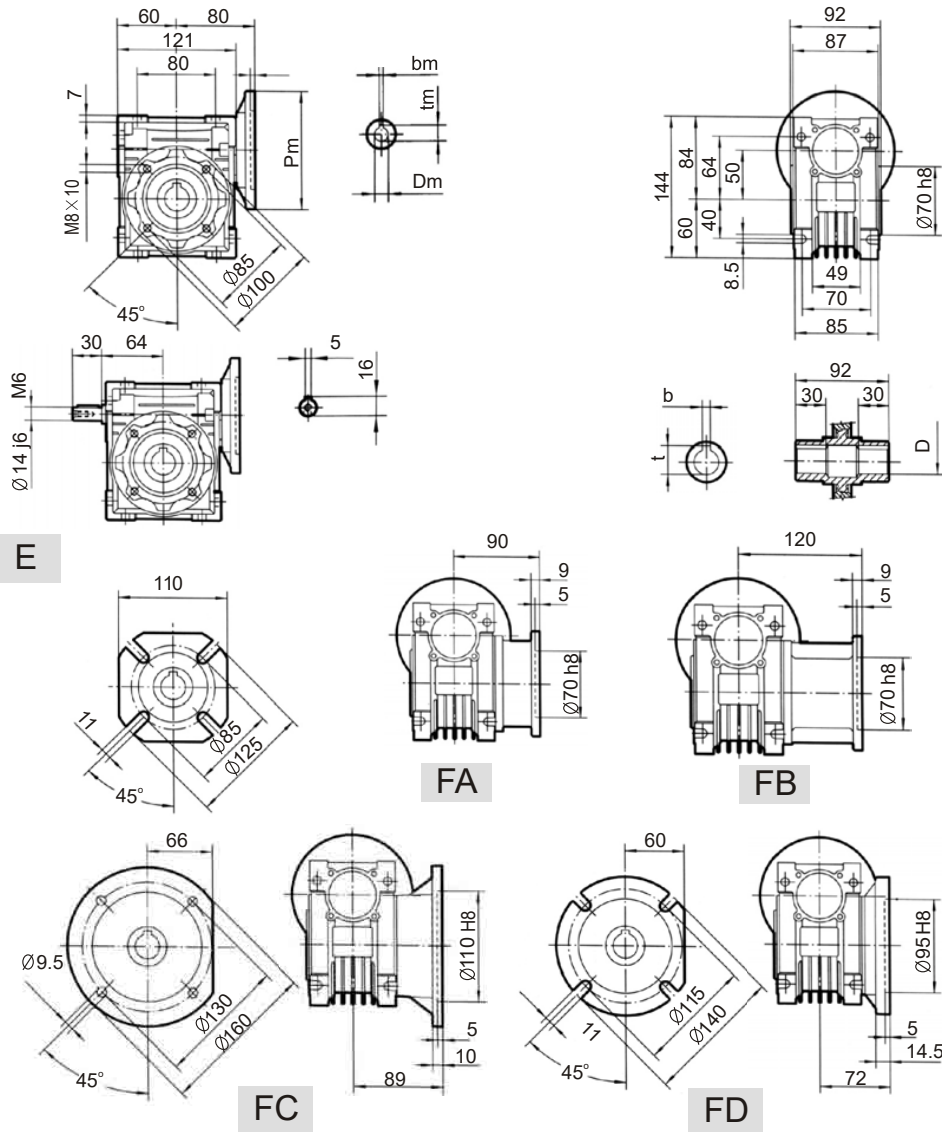

PAM IEC	Pm	Dm E8	bm	tm	DH8	b	t
8085	200	19	6	21.8	25	8	28.3
71B5	160	14	5	16.3	24*	8*	27.3*
6385	140	11	4	12.8	*Only on request		
80B14	120	19	6	21.8			
71B14	105	14	5	16.3			

■ WAŁEK WYJŚCIOWY

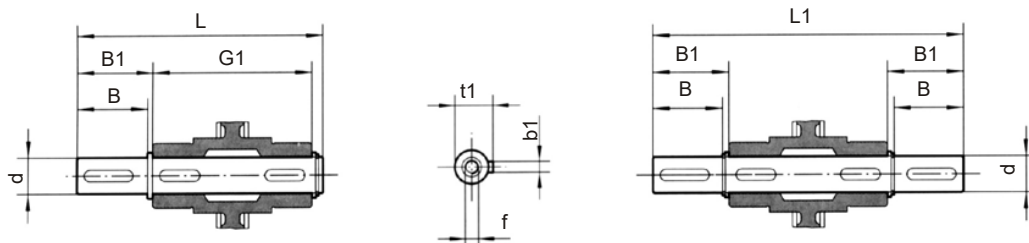

	dh6	B	B1	G1	L	L1	f	b1	t1
RV025	11g6	23	25.5	50	81	101	-	4	12.5
	9*	25*	30*	50	85.5*	101	-	3*	10.2*
RV030	14	30	32.5	63	102	128	M6	5	16
RV040	18	40	43	78	128	164	M5	6	20.5
RV050	25	50	53.5	92	153	199	M10	8	28
RV063	25	50	53.5	112	173	279	M10	8	28
RV075	28	60	63.5	120	192	247	M10	8	31
RV090	35	80	84.5	140	234	309	M12	10	38
RV110	42	80	84.5	155	249	324	M16	12	45
RV130	45	80	85	170	265	340	M16	14	48.5

*TYLKO NA ZAPYTANIE

■ RAMIĘ REAKCYJNE

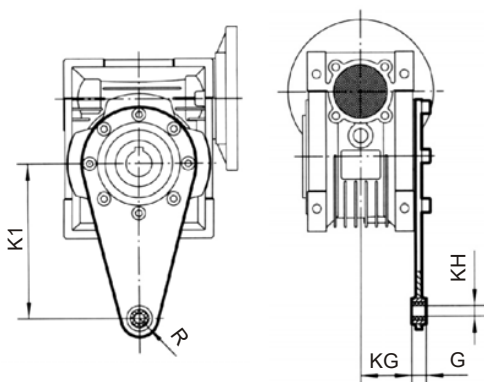

	K1	G	KG	KH	R
RV025	70	14	17.5	8	15
RV030	85	14	24	8	15
RV040	100	14	31.5	10	18
RV050	100	14	38.5	10	18
RV063	150	14	49	10	18
RV075	200	25	47.5	20	30
RV090	200	25	57.5	20	30
RV110	250	30	62	25	35
RV130	250	30	69	25	35

■ POKRYWA OCHRONNA

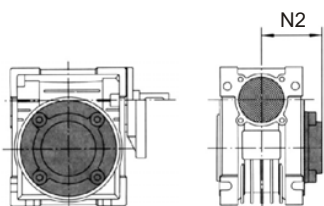

	N2		N2
RV030	47	RV075	79
RV040	55	RV090	94
RV050	63	RV110	102
RV063	73	RV130	117