

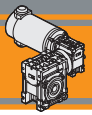

Ferrite

Motoriduttori CC a vite senza fine combinati
DC double reduction wormgearmotors





Indice	Index	Pag. Page
Caratteristiche tecniche	<i>Technical features</i>	Q2
Designazione	<i>Classification</i>	Q2
Simbologia	<i>Symbols</i>	Q2
Esecuzioni di montaggio	<i>Mounting executions</i>	Q2
Combinazioni rapporti	<i>Combination ratio</i>	Q3
Lubrificazione	<i>Lubrication</i>	Q3
Dati tecnici per servizio S2	<i>Technical data for S2 duty</i>	Q4
Motori applicabili	<i>Motor adapters</i>	Q9
Dimensioni	<i>Dimensions</i>	Q10
Accessori	<i>Accessories</i>	Q24
Opzioni	<i>Options</i>	Q24

Questa sezione annulla e sostituisce ogni precedente edizione o revisione. Qualora questa sezione non Vi sia giunta in distribuzione controllata, l'aggiornamento dei dati ivi contenuto non è assicurato. **In tal caso la versione più aggiornata è disponibile sul nostro sito internet www.transtecno.com**

This section replaces any previous edition and revision. If you obtained this catalogue other than through controlled distribution channels, the most up to date content is not guaranteed. In this case the latest version is available on our web site www.transtecno.com

**ECMM****Motoriduttori CC a vite senza fine combinati**
DC Double reduction wormgearmotors**Caratteristiche tecniche****Technical features**

Le caratteristiche principali dei motoriduttori CC a vite senza fine combinati a magneti permanenti in ferrite serie ECMM sono:

The main features of ECMM ferrite permanent magnets DC reduction wormgearmotors range are:

- Alimentazione in bassa tensione 12/24Vcc
- Possibilità di montaggio encoder
- Potenze motore disponibili da 100 a 800W S2
- Magneti in ferrite
- Carcassa in pressofusione di alluminio nelle grandezze 026, 030, 040, 050, 063, 075, 090 e 110. La grandezza 130 è costruita con carcassa in ghisa
- Lubrificazione permanente con olio sintetico
- Low voltage power supply 12/24Vdc
- Suitable for encoder assembly
- Motor power ratings available from 100 up to 800W S2
- Ferrite magnets
- Die cast aluminium housing on sizes 026, 030, 040, 050, 063, 075, 090 and 110. Cast iron housing on size 130
- Permanent synthetic oil long life lubrication

Designazione**Classification**

MOTORIDUTTORE / GEARMOTOR													
ECMM	100/026/026				U	150	SZDX	BRSX	90	B3	UB1	120	VS1
Tipo Type	Grandezza Size				Versione Version	Rapporto Ratio	Albero di uscita Output shaft	Braccio di reazione Torque arm	Angolo Angle	Pos. di montaggio Mounting position	Esecuzione di montaggio Mounting execution	Versione motore Motor version	Opzioni Options
	070/026/026	100/026/026	180/026/040	350/030/040	U F...	vedi tabelle see tables	SZDX SZSX DZ	BRDX BRSX *	0° 90° 180° 270°	B3 B8 B6 B7 V5 V6	UB1 UB2 US1 US2 UV1 UV2 UC1 UC2	120 240 24E	VS1 VS2
	070/026/026 (D11)	100/026/026 (D11)	180/026/050	350/030/050									
	070/026/026 (D14)	100/026/026 (D14)	180/030/040	350/030/063									
	070/026/030	100/026/030	180/030/050	350/040/070									
	070/026/040	100/026/040	180/030/063	350/040/075									
	070/026/050	100/026/050	180/040/070	350/040/090									
	070/030/040	100/030/040	180/040/075	350/050/110									
	070/030/050	100/030/050	180/040/090	350/063/130									
	070/030/063	100/030/063	180/050/110										
	070/040/070	100/040/075	250/030/040	600/040/070									
	070/040/075	100/040/090	250/030/050	600/040/075									
	070/040/090		250/030/063	600/040/090									
			250/040/070	600/050/110									
			250/040/075	600/063/130									
			250/040/090										
			250/050/110										

* NOTA: il braccio di reazione viene fornito smontato.
NOTE: the torque arm will be supplied not assembled.

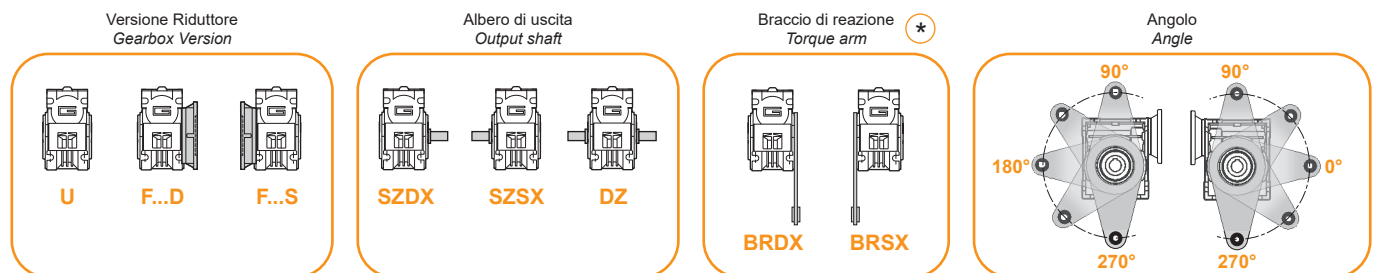
**Simbologia****Symbols**

n_1	[min ⁻¹]	Velocità in ingresso / Input speed	M_2	[Nm]	Coppia in uscita in funzione di P_1 / Output torque referred to P_1
n_2	[min ⁻¹]	Velocità in uscita / Output speed	sf		Fattore di servizio / Service factor
i		Rapporto di riduzione / Ratio	R_2	[N]	Carico radiale ammissibile in uscita / Permitted output radial load
P_1	[kW]	Potenza in entrata / Input power	A_2	[N]	Carico assiale ammissibile in uscita / Permitted output axial load



Esecuzioni di montaggio

Mounting executions

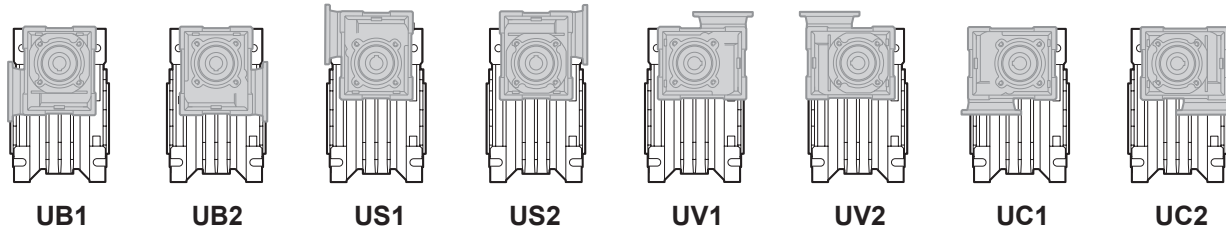

Combinazioni rapporti

Combination ratio

CMM 026/026 - CMM 026/030 - CMM 026/040 - CMM 026/050												
i (i ₁ x i ₂)												
	150	225	300	450	600	900	1200	1500	1800	2400	3000	3600
i ₁	10	15	10	15	20	30	40	50	60	60	60	60
i ₂	15	15	30	30	30	30	30	30	30	40	50	60

CMM 030/040 - CMM 030/050 - CMM 030/063 - CMM 040/070 - CMM 040/075 - CMM 040/090 - CMM 050/110 - CMM 063/130																
i (i ₁ x i ₂)																
	75	100	150	200	250	300	400	500	600	750	900	1200	1500	1800	2400	3000
i ₁	7.5	10	10	10	10	10	10	10	20	25	30	40	50	60	60	60
i ₂	10	10	15	20	25	30	40	50	30	30	30	30	30	30	40	50

Lubrificazione

Lubrication

Tutti i motoriduttori nelle taglie 26, 30, 40, 50, 63, 70, 75, 90, 110 sono forniti completi di lubrificante sintetico viscosità 320, pertanto possono essere installati in qualunque posizione di montaggio e non necessitano di manutenzione. Per la taglia 130 la lubrificazione dipende dalla posizione di montaggio

Permanent synthetic oil long-life lubrication (viscosity grade 320) makes it possible to use the gearmotors size 26, 30, 40, 50, 63, 70, 75, 90, 110 in all mounting positions; for this reason they can be installed in any assembly position and do not require maintenance. Only for size 130, the lubrication depended of mounting positions

Quantità di olio (litri) / Oil quantity (litres)						
	M1 (B3)	M3 (B8)	M6 (B6)	M5 (B7)	M4 (V5)	M2 (V6)
CM130	4.5	3.3	3.5	3.5	4.5	3.3

Lubrificato a vita
Life lubrication

Posizioni di montaggio / Mounting positions

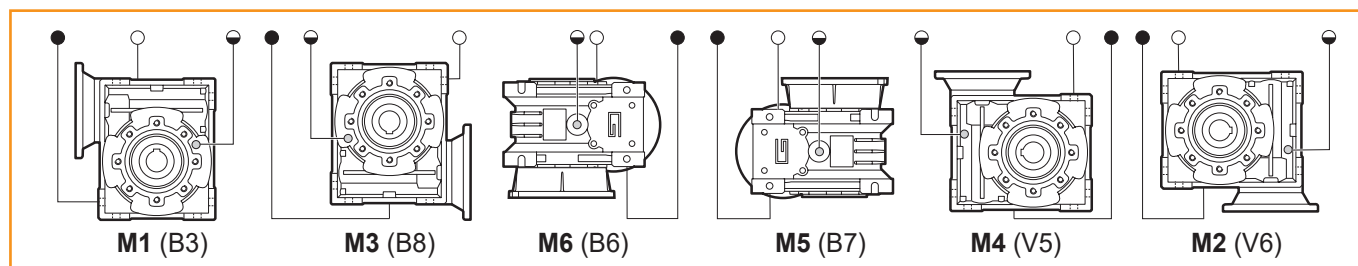



(standard)

- Sfiato e tappo di riempimento / Breather and filling plug
- ◐ Livello olio / Oil level plug
- Tappo di scarico / Oil drain plug



Dati tecnici per servizio S2

Technical data for S2 duty

P_1 [W]	n_2 [min ⁻¹]	M_2 [Nm]	sf	i		Versione motore Motor version	P_1 [W]	n_2 [min ⁻¹]	M_2 [Nm]	sf	i		Versione motore Motor version					
100							100											
(3000 min ⁻¹)	20.0	26	1.0	150	ECMM 070/026/026	12E/24E	(3000 min ⁻¹)	40.0	15	5.5	75	ECMM 070/030/040	12E/24E					
	13.3	26	1.0	225					30.0	20	4.2			100				
	10.0	27	1.0	300					20.0	28	3.2			150				
	6.7	27	1.0	450					15.0	36	2.1			200				
	5.0	27	1.0	600					12.0	43	1.6			250				
	3.3	27	1.0	900					10.0	46	2.0			300				
	2.5	27	1.0	1200					7.5	55	1.3			400				
	2.0	27	1.0	1500					6.0	63	1.1			500				
	1.7	27	1.0	1800					5.0	86	1.0			600				
	1.3	22	1.0	2400					4.0	103	0.9			750				
	1.0	20	1.0	3000					3.3	118	0.8			900				
	0.8	18	1.0	3600					2.5	74	1.0			1200				
									2.0	90	1.0			1500				
	20.0	26	1.5	150			ECMM 070/026/030	12E/24E		1.7	90			1.0	1800			
	13.3	39	1.0	225							1.3			74	1.0	2400		
	10.0	40	1.0	300					1.0	68	1.0	3000						
	6.7	40	1.0	450														
	5.0	40	1.0	600					15.0	36	3.8	200	ECMM 070/030/050	12E/24E				
	3.3	40	1.0	900					12.0	43	2.9	250						
	2.5	40	1.0	1200					10.0	46	3.5	300						
	2.0	40	1.0	1500					7.5	57	2.4	400						
	1.7	40	1.0	1800					6.0	64	2.0	500						
	1.3	34	1.0	2400					5.0	87	1.9	600						
	1.0	30	1.0	3000					4.0	105	1.5	750						
	0.8	27	1.0	3600					3.3	120	1.4	900						
									2.5	146	0.9	1200						
	20.0	27	3.2	150	ECMM 070/026/040	12E/24E				2.0	175	0.9			1500			
	13.3	40	2.2	225							1.7	201			0.8	1800		
	10.0	45	2.0	300					1.3	135	1.0	2400						
	6.7	66	1.4	450					1.0	125	1.0	3000						
	5.0	85	1.1	600														
	3.3	90	1.0	900					4.0	109	2.8	750			ECMM 070/030/063	12E/24E		
	2.5	90	1.0	1200					3.3	124	2.5	900						
	2.0	90	1.0	1500					2.5	149	1.7	1200						
	1.7	90	1.0	1800					2.0	181	1.7	1500						
	1.3	74	1.0	2400					1.7	208	1.5	1800						
	1.0	68	1.0	3000					1.3	249	1.0	2400						
	0.8	62	1.0	3600					1.0	288	0.8	3000						
	20.0	28	5.7	150			ECMM 070/026/050	12E/24E		2.5	155	2.5	1200	ECMM 070/040/070			12E/24E	
	13.3	42	3.9	225							2.0	193	2.4					1500
	10.0	46	3.5	300					1.7	221	2.1	1800						
	6.7	67	2.4	450					1.3	265	1.4	2400						
	5.0	86	1.9	600					1.0	307	1.1	3000						
	3.3	118	1.4	900														
	2.5	147	1.1	1200					2.5	158	3.0	1200	ECMM 070/040/075					12E/24E
	2.0	162	1.0	1500					2.0	193	2.8	1500						
	1.7	162	1.0	1800					1.7	221	2.5	1800						
	1.3	135	1.0	2400					1.3	270	1.7	2400						
	1.0	125	1.0	3000					1.0	307	1.3	3000						
	0.8	113	1.0	3600														
									1.3	285	2.9	2400			ECMM 070/040/090	12E/24E		
									1.0	331	2.1	3000						



N.B.
Verificare sempre che la coppia M2 utilizzata non ecceda il valore indicato nelle caselle in grigio
N.B.
Please check that the output torque M2 does not exceed the value in the grey areas

NOTA: per servizio continuo o altamente intermittente, contattare il servizio tecnico
NOTE: for continuous or highly intermittent duty, please contact our technical service



Dati tecnici per servizio S2

Technical data for S2 duty

P_1 [W]	n_2 [min ⁻¹]	M_2 [Nm]	sf	i		Versione motore Motor version	P_1 [W]	n_2 [min ⁻¹]	M_2 [Nm]	sf	i		Versione motore Motor version					
140							140											
(3000 min ⁻¹)	20.0	26	1.0	150	ECMM 100/026/026	120/240/24E	(3000 min ⁻¹)	40.0	21	3.9	75	ECMM 100/030/040	120/240/24E					
	13.3	26	1.0	225					30.0	28	3.0			100				
	10.0	27	1.0	300					20.0	38	2.3			150				
	6.7	27	1.0	450					15.0	50	1.5			200				
	5.0	27	1.0	600					12.0	59	1.1			250				
	3.3	27	1.0	900					10.0	63	1.4			300				
	2.5	27	1.0	1200					7.5	77	1.0			400				
	2.0	27	1.0	1500					6.0	87	0.8			500				
	1.7	27	1.0	1800					5.0	119	0.8			600				
	1.3	22	1.0	2400					4.0	90	1.0			750				
	1.0	20	1.0	3000					3.3	90	1.0			900				
	0.8	18	1.0	3600					2.5	74	1.0			1200				
									2.0	90	1.0			1500				
	20.0	37	1.1	150			ECMM 100/026/030	120/240/24E	1.7	90	1.0			1800				
	13.3	39	1.0	225							1.3			74	1.0	2400		
	10.0	40	1.0	300					1.0	68	1.0	3000						
	6.7	40	1.0	450														
	5.0	40	1.0	600					15.0	50	2.7	200	ECMM 100/030/050	120/240/24E				
	3.3	40	1.0	900					12.0	59	2.1	250						
	2.5	40	1.0	1200					10.0	64	2.5	300						
	2.0	40	1.0	1500					7.5	78	1.7	400						
	1.7	40	1.0	1800					6.0	89	1.4	500						
	1.3	34	1.0	2400					5.0	121	1.3	600						
	1.0	30	1.0	3000					4.0	146	1.1	750						
	0.8	27	1.0	3600					3.3	166	1.0	900						
									2.5	202	0.7	1200						
	20.0	38	2.3	150	ECMM 100/026/040	120/240/24E			2.0	243	0.7	1500						
	13.3	55	1.6	225							1.7	162			1.0	1800		
	10.0	63	1.4	300					1.3	135	1.0	2400						
	6.7	92	1.0	450					1.0	125	1.0	3000						
	5.0	90	1.0	600														
	3.3	90	1.0	900					6.0	92	2.5	500			ECMM 100/030/063	120/240/24E		
	2.5	90	1.0	1200					5.0	125	2.5	600						
	2.0	90	1.0	1500					4.0	151	2.1	750						
	1.7	90	1.0	1800					3.3	172	1.8	900						
	1.3	74	1.0	2400					2.5	206	1.3	1200						
	1.0	68	1.0	3000					2.0	252	1.2	1500						
	0.8	62	1.0	3600					1.7	288	1.1	1800						
									1.3	346	0.8	2400						
	20.0	39	4.1	150			ECMM 100/026/050	120/240/24E	1.0	232	1.0	3000						
	13.3	58	2.8	225														
	10.0	64	2.5	300					3.3	179	2.5	900	ECMM 100/040/070	120/240/24E				
	6.7	93	1.7	450					2.5	215	1.8	1200						
	5.0	120	1.4	600					2.0	267	1.7	1500						
	3.3	164	1.0	900					1.7	307	1.5	1800						
	2.5	162	1.0	1200					1.3	368	1.0	2400						
	2.0	162	1.0	1500					1.0	426	0.8	3000						
	1.7	162	1.0	1800														
	1.3	135	1.0	2400					3.3	179	3.1	900			ECMM 100/040/075	120/240/24E		
	1.0	125	1.0	3000					2.5	219	2.2	1200						
	0.8	113	1.0	3600					2.0	267	2.0	1500						
									1.7	307	1.8	1800						
									1.3	375	1.3	2400						
									1.0	426	0.9	3000						
							1.7	322	2.9	1800	ECMM 100/040/090	120/240/24E						
							1.3	395	2.1	2400								
							1.0	460	1.5	3000								







N.B.
Verificare sempre che la coppia M2 utilizzata non ecceda il valore indicato nelle caselle in grigio
N.B.







Please check that the output torque M2 does not exceed the value in the grey areas

NOTA: per servizio continuo o altamente intermittente, contattare il servizio tecnico

NOTE: for continuous or highly intermittent duty, please contact our technical service

**Dati tecnici per servizio S2****Technical data for S2 duty**

P_1 [W]	n_2 [min ⁻¹]	M_2 [Nm]	sf	i		Versione motore Motor version		
250								
(3000 min ⁻¹)	20.0	70	1.2	150		ECMM 180/026/040 120/240		
	13.3	103	0.8	225				
	10.0	116	0.8	300				
	20.0	73	2.2	150		ECMM 180/026/050 120/240		
	13.3	108	1.5	225				
	10.0	118	1.4	300				
	6.7	173	0.9	450				
	5.0	223	0.7	600				
	40.0	40	2.1	75				ECMM 180/030/040 120/240/24E
	30.0	52	1.6	100				
	20.0	71	1.2	150				
	15.0	92	0.8	200				
	12.0	67	1.0	250				
	10.0	90	1.0	300				
	7.5	74	1.0	400				
	6.0	68	1.0	500				
	5.0	90	1.0	600				
	4.0	90	1.0	750				
	3.3	90	1.0	900				
	40.0	40	3.9	75		ECMM 180/030/050 120/240/24E		
	30.0	52	3.0	100				
	20.0	74	2.2	150				
	15.0	94	1.5	200				
	12.0	110	1.1	250				
	10.0	120	1.4	300				
	7.5	146	0.9	400				
	6.0	165	0.8	500				
	5.0	226	0.7	600				
	4.0	162	1.0	750				
	3.3	162	1.0	900				
	2.5	135	1.0	1200				
	2.0	162	1.0	1500				
	1.7	162	1.0	1800				
	15.0	92	2.8	200				ECMM 180/030/063 120/240/24E
	12.0	108	2.1	250				
	10.0	124	2.5	300				
	7.5	149	1.7	400				
	6.0	172	1.3	500				
	5.0	233	1.3	600				
	4.0	281	1.1	750				
	3.3	320	1.0	900				
	2.5	384	0.7	1200				
	2.0	468	0.7	1500				
	1.7	310	1.0	1800				
	1.3	260	1.0	2400				
	1.0	232	1.0	3000				
	12.0	113	3.0	250		ECMM 180/040/070 120/240/24E		
	10.0	125	3.6	300				
	7.5	150	2.5	400				
	6.0	174	1.9	500				
	5.0	239	1.9	600				
	4.0	288	1.6	750				
	3.3	333	1.4	900				
	2.5	399	0.9	1200				
	2.00	497	0.9	1500				
	1.67	570	0.8	1800				
	1.25	379	1.0	2400				
	1.00	336	1.0	3000				

P_1 [W]	n_2 [min ⁻¹]	M_2 [Nm]	sf	i		Versione motore Motor version		
250								
(3000 min ⁻¹)	12.0	113	3.6	250		ECMM 180/040/075 120/240/24E		
	10.0	125	4.4	300				
	7.5	153	3.1	400				
	6.0	174	2.3	500				
	5.0	239	2.3	600				
	4.0	288	1.9	750				
	3.3	333	1.6	900				
	2.5	407	1.2	1200				
	2.0	497	1.1	1500				
	1.7	570	1.0	1800				
	1.3	470	1.0	2400				
	1.0	403	1.0	3000				
	5.0	251	3.8	600				ECMM 180/040/090 120/240/24E
	4.0	302	3.1	750				
	3.3	349	2.7	900				
	2.5	429	1.9	1200				
	2.0	522	1.8	1500				
	1.7	599	1.6	1800				
	1.3	735	1.1	2400				
	1.0	855	0.8	3000				
	3.3	359	4.4	900		ECMM 180/050/110 24E 120/240/24E		
	2.5	457	3.2	1200				
	2.0	545	2.9	1500				
	1.7	627	2.5	1800				
	1.3	796	1.8	2400				
	1.0	947	1.3	3000				
350								
(3000 min ⁻¹)	40.0	55	1.5	75				ECMM 250/030/040 120/240
	30.0	72	1.2	100				
	20.0	100	0.9	150				
	15.0	74	1.0	200				
	12.0	67	1.0	250				
	10.0	90	1.0	300				
	7.5	74	1.0	400				
	6.0	68	1.0	500				
	5.0	90	1.0	600				
	4.0	90	1.0	750				
	3.3	90	1.0	900				
	2.5	74	1.0	1200				
	2.0	90	1.0	1500				
	40.0	56	2.8	75		ECMM 250/030/050 120/240		
	30.0	73	2.1	100				
	20.0	104	1.5	150				
	15.0	131	1.0	200				
	12.0	154	0.8	250				
	10.0	168	1.0	300				
	7.5	204	0.7	400				
	6.0	125	1.0	500				
	5.0	162	1.0	600				
	4.0	162	1.0	750				
	3.3	162	1.0	900				
	2.5	135	1.0	1200				
	2.00	162	1.0	1500				

N.B.
Verificare sempre che la coppia M2 utilizzata non ecceda il valore indicato nelle caselle in grigio
N.B.
Please check that the output torque M2 does not exceed the value in the grey areas





NOTA: per servizio continuo o altamente intermittente, contattare il servizio tecnico





NOTE: for continuous or highly intermittent duty, please contact our technical service



Dati tecnici per servizio S2

Technical data for S2 duty

P_1 [W]	n_2 [min ⁻¹]	M_2 [Nm]	sf	i		Versione motore Motor version		
350								
(3000 min ⁻¹)	30.0	74	3.9	100		ECMM 250/030/063 120/240		
	20.0	103	3.0	150				
	15.0	129	2.0	200				
	12.0	152	1.5	250				
	10.0	173	1.8	300				
	7.5	208	1.2	400				
	6.0	241	1.0	500				
	5.0	327	0.9	600				
	4.0	393	0.8	750				
	3.3	448	0.7	900				
	2.5	260	1.0	1200				
	2.00	310	1.0	1500				
	15.0	133	2.9	200				ECMM 250/040/070 120/240
	12.0	158	2.2	250				
	10.0	175	2.6	300				
	7.5	210	1.8	400				
	6.0	244	1.4	500				
	5.0	335	1.4	600				
	4.0	403	1.1	750				
	3.3	466	1.0	900				
	2.5	379	1.0	1200				
	2.00	453	1.0	1500				
	1.67	453	1.0	1800				
	1.25	379	1.0	2400				
	1.00	336	1.0	3000				
	15.0	134	3.5	200		ECMM 250/040/075 120/240		
	12.0	158	2.6	250				
	10.0	175	3.1	300				
	7.5	214	2.2	400				
	6.0	244	1.7	500				
	5.0	335	1.6	600				
	4.0	403	1.4	750				
	3.3	466	1.2	900				
	2.5	569	0.8	1200				
	2.00	696	0.8	1500				
	1.67	547	1.0	1800				
	1.25	470	1.0	2400				
	1.00	403	1.0	3000				
	12.0	168	4.2	250				ECMM 250/040/090 120/240
	10.0	184	5.1	300				
	7.5	226	3.6	400				
	6.0	263	2.6	500				
	5.0	351	2.7	600				
	4.0	423	2.2	750				
	3.3	489	1.9	900				
	2.5	600	1.4	1200				
	2.00	730	1.3	1500				
	1.67	838	1.1	1800				
	1.25	1029	0.8	2400				
	1.00	689	1.0	3000				

P_1 [W]	n_2 [min ⁻¹]	M_2 [Nm]	sf	i		Versione motore Motor version		
350								
(3000 min ⁻¹)	6.0	286	4.5	500		ECMM 250/050/110 120/240		
	5.0	361	4.4	600				
	4.0	441	3.6	750				
	3.3	503	3.2	900				
	2.5	639	2.3	1200				
	2.00	763	2.1	1500				
	1.67	877	1.8	1800				
	1.25	1115	1.3	2400				
	1.00	1325	1.0	3000				
500								
(3000 min ⁻¹)	40.0	78	1.1	75		ECMM 350/030/040 120/240		
	30.0	101	0.8	100				
	20.0	87	1.0	150				
	15.0	74	1.0	200				
	12.0	67	1.0	250				
	10.0	90	1.0	300				
	7.5	74	1.0	400				
	40.0	79	2.0	75				ECMM 350/030/050 120/240
	30.0	103	1.5	100				
	20.0	146	1.1	150				
	15.0	184	0.7	200				
	12.0	216	0.6	250				
	10.0	235	0.7	300				
	7.5	135	1.0	400				
	6.0	125	1.0	500				
	5.0	162	1.0	600				
	4.0	162	1.0	750				
	3.3	162	1.0	900				
	40.0	80	3.6	75		ECMM 350/030/063 120/240		
	30.0	104	2.8	100				
	20.0	144	2.1	150				
	15.0	181	1.4	200				
	12.0	213	1.1	250				
	10.0	243	1.3	300				
	7.5	292	0.9	400				
	6.0	338	0.7	500				
	5.0	458	0.7	600				
	4.0	310	1.0	750				
	3.3	310	1.0	900				
	2.5	260	1.0	1200				
	2.0	310	1.0	1500				

N.B.
Verificare sempre che la coppia M2 utilizzata non ecceda il valore indicato nelle caselle in grigio
N.B.
Please check that the output torque M2 does not exceed the value in the grey areas

NOTA: per servizio continuo o altamente intermittente, contattare il servizio tecnico

NOTE: for continuous or highly intermittent duty, please contact our technical service

**Dati tecnici per servizio S2****Technical data for S2 duty**

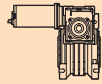
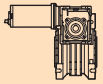
P_1 [W]	n_2 [min ⁻¹]	M_2 [Nm]	sf	i		Versione motore Motor version	P_1 [W]	n_2 [min ⁻¹]	M_2 [Nm]	sf	i		Versione motore Motor version				
500							800										
(3000 min ⁻¹)	20.0	148	3.0	150	ECMM 350/040/070	120/240	(3000 min ⁻¹)	40.0	132	3.2	75	ECMM 600/040/070	120/240				
	15.0	186	2.1	200				30.0	172	2.4	100						
	12.0	222	1.5	250				20.0	239	1.8	150						
	10.0	246	1.8	300				15.0	301	1.3	200						
	7.5	295	1.3	400				12.0	359	0.9	250						
	6.0	341	1.0	500				10.0	398	1.1	300						
	5.0	469	1.0	600				7.5	477	0.8	400						
	4.0	565	0.8	750				6.0	336	1.0	500						
	3.3	653	0.7	900				5.0	453	1.0	600						
	2.5	379	1.0	1200				4.0	453	1.0	750						
	2.00	453	1.0	1500				3.3	453	1.0	900						
	1.67	453	1.0	1800				2.5	379	1.0	1200						
	1.25	379	1.0	2400													
	20.0	150	3.5	150			ECMM 350/040/075	120/240	40.0	132	3.8			75	ECMM 600/040/075	120/240	
	15.0	188	2.5	200						30.0	172			2.9			100
	12.0	222	1.8	250						20.0	242			2.2			150
	10.0	246	2.2	300						15.0	305			1.5			200
	7.5	300	1.6	400						12.0	359			1.1			250
	6.0	341	1.2	500						10.0	398			1.4			300
	5.0	469	1.2	600						7.5	486			1.0			400
	4.0	565	1.0	750		6.0			403	1.0	500						
	3.3	653	0.8	900		5.0			547	1.0	600						
	2.5	470	1.0	1200		4.0			547	1.0	750						
	2.0	547	1.0	1500		3.3			547	1.0	900						
	1.7	547	1.0	1800		2.5			470	1.0	1200						
	1.3	470	1.0	2400													
	12.0	236	3.0	250	ECMM 350/040/090	120/240	20.0	249	3.5	150	ECMM 600/040/090	120/240					
	10.0	258	3.7	300				15.0	318	2.5			200				
	7.5	317	2.6	400				12.0	381	1.9			250				
	6.0	369	1.9	500				10.0	418	2.3			300				
	5.0	493	1.9	600				7.5	513	1.6			400				
	4.0	593	1.6	750				6.0	597	1.2			500				
	3.3	685	1.4	900				5.0	797	1.2			600				
	2.5	841	1.0	1200				4.0	960	1.0			750				
	2.0	1024	0.9	1500				3.3	1109	0.9			900				
	1.7	1175	0.8	1800				2.5	813	1.0			1200				
	1.3	813	1.0	2400													
	1.0	689	1.0	3000													
	6.0	401	3.2	500	ECMM 350/050/110	120/240	12.0	402	3.2	250	ECMM 600/050/110	120/240					
	5.0	506	3.1	600				10.0	429	3.7			300				
	4.0	618	2.6	750				7.5	545	2.6			400				
	3.3	705	2.3	900				6.0	648	2.0			500				
	2.5	896	1.6	1200				5.0	819	1.9			600				
	2.0	1070	1.5	1500				4.0	1000	1.6			750				
	1.7	1230	1.3	1800				3.3	1141	1.4			900				
	1.3	1563	0.9	2400				2.5	1450	1.0			1200				
	1.0	1272	1.0	3000				2.0	1731	0.9			1500				
								1.7	1990	0.8			1800				
								1.3	1443	1.0			2400				
								1.0	1272	1.0			3000				
	4.0	645	2.6	750	ECMM 350/063/130	120/240	7.5	563	2.8	400	ECMM 600/063/130	120/240					
	3.3	737	2.3	900				6.0	682	2.2			500				
	2.5	938	1.7	1200				5.0	845	2.0			600				
	2.0	1135	1.5	1500				4.0	1044	1.6			750				
	1.7	1306	1.3	1800				3.3	1192	1.4			900				
	1.3	1662	1.0	2400				2.5	1517	1.1			1200				
	1.0	2011	0.7	3000				2.0	1836	0.9			1500				
								1.7	2112	0.8			1800				
								1.3	1600	1.0			2400				
								1.0	1500	1.0			3000				

N.B.
Verificare sempre che la coppia M_2 utilizzata non ecceda il valore indicato nelle caselle in grigio
N.B.
Please check that the output torque M_2 does not exceed the value in the grey areas

NOTA: per servizio continuo o altamente intermittente, contattare il servizio tecnico

NOTE: for continuous or highly intermittent duty, please contact our technical service



Motori applicabili

Motor adapters

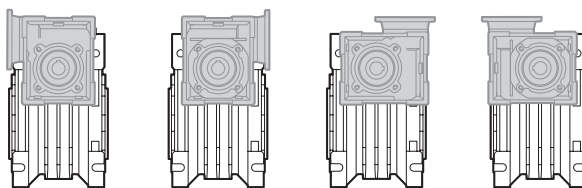

US1

US2

UV1

UV2

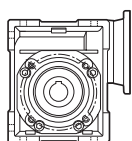

		EC			
		070.12E 070.24E	100.120 100.240	100.24E	180.120 180.240
CMM	026/026	150 - 3600	150 - 3600	150 - 3600	150 - 3600

150 - 3600

Rapporti di riduzione i
Ratio i

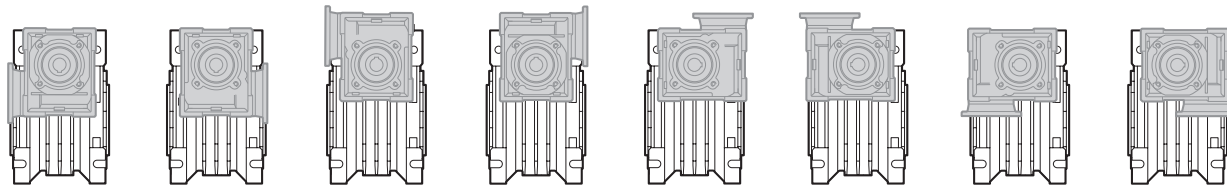

UB1

UB2

US1

US2

UV1

UV2

UC1

UC2

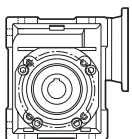

		EC							
		070.12E 070.24E	100.120 100.240	100.24E	180.120 180.240	180.24E	250.120 250.240	350.120 350.240	600.120 600.240
CMM	026/030	150 - 3600	150 - 3600	150 - 3600	150 - 3600				
	026/040	150 - 3600	150 - 3600	150 - 3600	150 - 3600				
	026/050	150 - 3600	150 - 3600	150 - 3600	150 - 3600				
	030/040	75 - 3000	75 - 3000	75 - 3000	75 - 3000	75 - 1500	75 - 1500	75 - 1500	
	030/050	75 - 3000	75 - 3000	75 - 3000	75 - 3000	75 - 1500	75 - 1500	75 - 1500	
	030/063	75 - 3000	75 - 3000	75 - 3000	75 - 3000	75 - 1500	100 - 1500	75 - 1500	
	040/070	75 - 3000	75 - 3000	75 - 3000	75 - 3000	75 - 3000	200 - 3000	75 - 3000	75 - 1200
	040/075	75 - 3000	75 - 3000	75 - 3000	75 - 3000	75 - 3000	200 - 3000	75 - 3000	75 - 1200
	040/090	75 - 3000	75 - 3000	75 - 3000	75 - 3000	75 - 3000	250 - 3000	75 - 3000	75 - 1200
	050/110				1200 - 3000	75 - 3000	500 - 3000	75 - 3000	75 - 3000
063/130							75 - 3000	75 - 3000	

150 - 3600

Rapporti di riduzione i
Ratio i



Dimensioni

Dimensions

CMM..U - CMM..F..																	
	A	C	D _{H8}	E	F	G	G1	H	H1	I	I1	K	L	M	N _{h8}	N1	N2
026/026 (D11)	45	70	11	83	22	47.5	50	35	34	26	26	34	42	55	45	22.5	21
026/026			12														
026/026 (D14)			14														
026/030	54	80	14	97	32	47.5	63	40	34	30	26	44	56	65	55	29	21
026/040	70	100	18	121.5	43	47.5	78	50	34	40	26	60	71	75	60	36.5	21
026/050	80	120	25	144	49	47.5	92	60	34	50	26	70	85	85	70	43.5	21
030/040	70	100	18	121.5	43	55	78	50	40	40	30	60	71	75	60	36.5	29
030/050	80	120	25	144	49	55	92	60	40	50	30	70	85	85	70	43.5	29
030/063	100	144	25	174	67	55	112	72	40	63	30	85	104	95	80	53	29
040/070	110	160	28	195	64	70	120	80	50	70	40	90	104	115	95	57	35.5
040/075	120	172	28	205	72	70	120	86	50	75	40	90	112	115	95	57	36.5
040/090	140	208	35	238	74	70	140	103	50	90	40	100	130	130	110	67	36.5

CMM..U - CMM..F..														
	O	P	Q	R	R1	S	T	V	Z	KE	a	b	t	Kg (*)
026/026 (D11)	6	—	37	49	49	5	15	21	76	7	—	4	12.8	3.3
026/026												4	13.8	
026/026 (D14)												5	16.2	
026/030	6.5	75	44	57	49	5.5	22	27	81	M6x10(n.4)	90°	5	16.3	4.1
026/040	6.5	87	55	71.5	49	6.5	26	35	91.5	M6x8(n.4)	45°	6	20.8	5.2
026/050	8.5	98	64	84	49	7	30	40	100.5	M8x10(n.4)	45°	8	28.3	6.7
030/040	6.5	87	55	71.5	57	6.5	26	35	122	M6x8(n.4)	45°	6	20.8	5.6
030/050	8.5	98	64	84	57	7	30	40	132	M8x10(n.4)	45°	8	28.3	6.7
030/063	8.5	110	80	102	57	8	36	50	145	M8x14(n.8)	45°	8	28.3	8.7
040/070	9	130	91	115	71.5	9	40	55	160	M8x14(n.8)	45°	8	31.3	12.7
040/075	11	140	93	119	71.5	10	40	60	165	M8x14(n.8)	45°	8	31.3	13.7
040/090	13	160	102	135	71.5	11	45	70	182	M10x18(n.8)	45°	10	38.3	17.3

(*) **Nota:** Il peso in kg si riferisce al motoriduttore ECMM 070 /...
Note: The weight in kg is referred to the gearmotor ECMM 070 /...



Dimensioni

Dimensions

ECMM070/...U

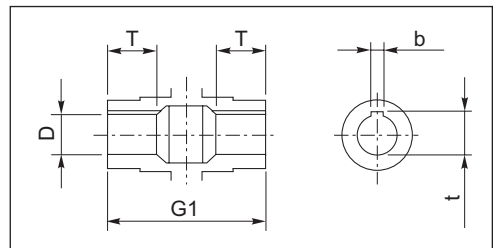
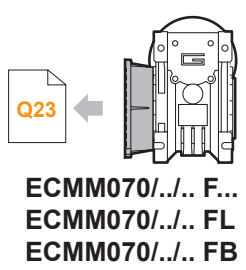
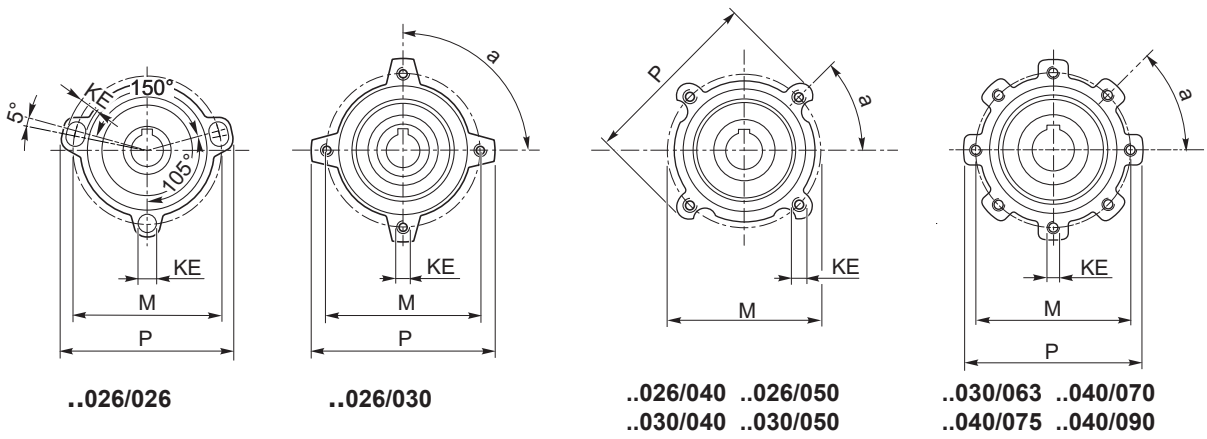
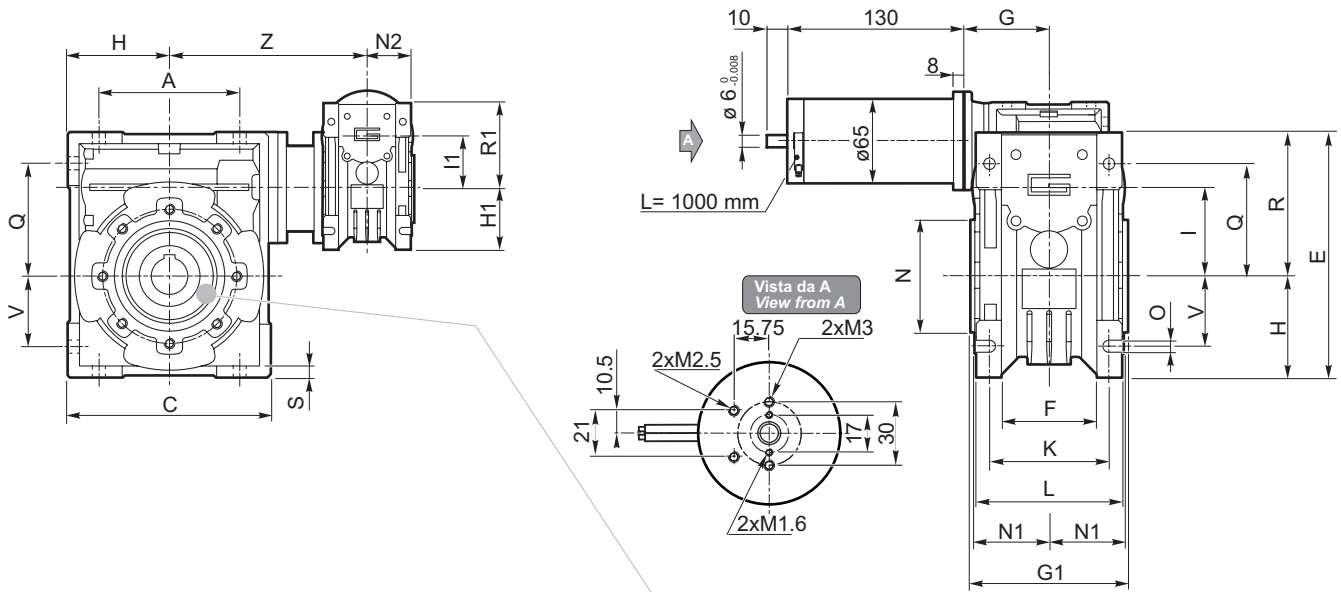

Albero lento cavo / Hollow output shaft

Motori / Motors IP66 → I2

Freno / Brake → H23

Encoder → H24

ECMM



Dimensioni

Dimensions

CMM..U - CMM..F...																	
	A	C	D _{H8}	E	F	G	G1	H	H1	I	I1	K	L	M	N _{H8}	N1	N2
026/026 (D11)	45	70	11	83	22	47.5	50	35	34	26	26	34	42	55	45	22.5	21
026/026			12														
026/026 (D14)			14														
026/030	54	80	14	97	32	47.5	63	40	34	30	26	44	56	65	55	29	21
026/040	70	100	18	121.5	43	47.5	78	50	34	40	26	60	71	75	60	36.5	21
026/050	80	120	25	144	49	47.5	92	60	34	50	26	70	85	85	70	43.5	21
030/040	70	100	18	121.5	43	55	78	50	40	40	30	60	71	75	60	36.5	29
030/050	80	120	25	144	49	55	92	60	40	50	30	70	85	85	70	43.5	29
030/063	100	144	25	174	67	55	112	72	40	63	30	85	104	95	80	53	29
040/070	110	160	28	195	64	70	120	80	50	70	40	90	104	115	95	57	35.5
040/075	120	172	28	205	72	70	120	86	50	75	40	90	112	115	95	57	36.5
040/090	140	208	35	238	74	70	140	103	50	90	40	100	130	130	110	67	36.5

CMM..U - CMM..F...															
	O	P	Q	R	R1	S	T	V	Z	KE	a	b	t	Kg (*)	
026/026 (D11)	6	—	37	49	49	5	15	21	76	7	—	4	12.8	3.3	
026/026												4	13.8		
026/026 (D14)												5	16.2		
026/030	6.5	75	44	57	49	5.5	22	27	81	M6x10(n.4)	90°	5	16.3	5.1	
026/040	6.5	87	55	71.5	49	6.5	26	35	91.5	M6x8(n.4)	45°	6	20.8	6.2	
026/050	8.5	98	64	84	49	7	30	40	100.5	M8x10(n.4)	45°	8	28.3	7.7	
030/040	6.5	87	55	71.5	57	6.5	26	35	122	M6x8(n.4)	45°	6	20.8	6.6	
030/050	8.5	98	64	84	57	7	30	40	132	M8x10(n.4)	45°	8	28.3	7.7	
030/063	8.5	110	80	102	57	8	36	50	145	M8x14(n.8)	45°	8	28.3	9.7	
040/070	9	130	91	115	71.5	9	40	55	160	M8x14(n.8)	45°	8	31.3	13.7	
040/075	11	140	93	119	71.5	10	40	60	165	M8x14(n.8)	45°	8	31.3	14.7	
040/090	13	160	102	135	71.5	11	45	70	182	M10x18(n.8)	45°	10	38.3	18.3	

(*) **Nota:** Il peso in kg si riferisce al motoriduttore ECMM 100 /...
Note: The weight in kg is referred to the gearmotor ECMM 100 /...



Dimensioni

Dimensions

ECMM100/...U

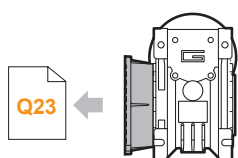
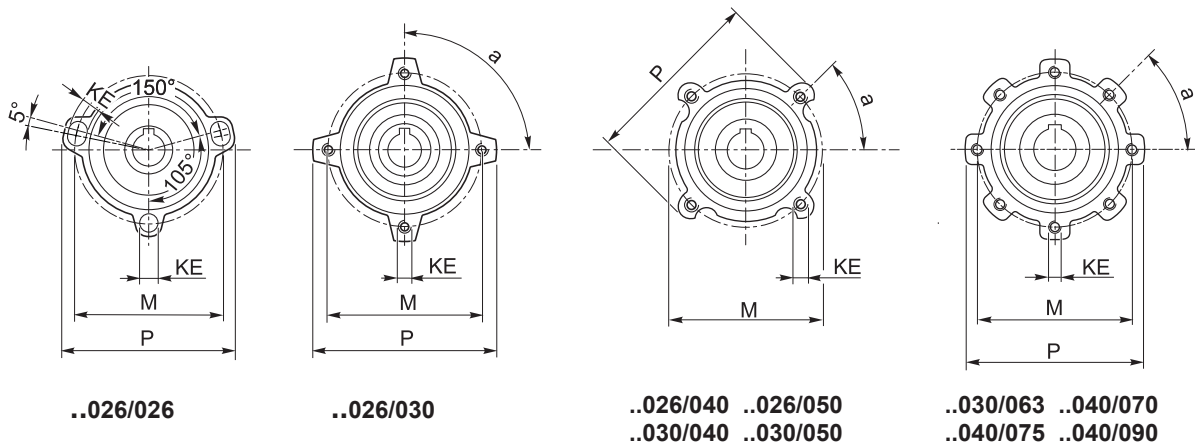
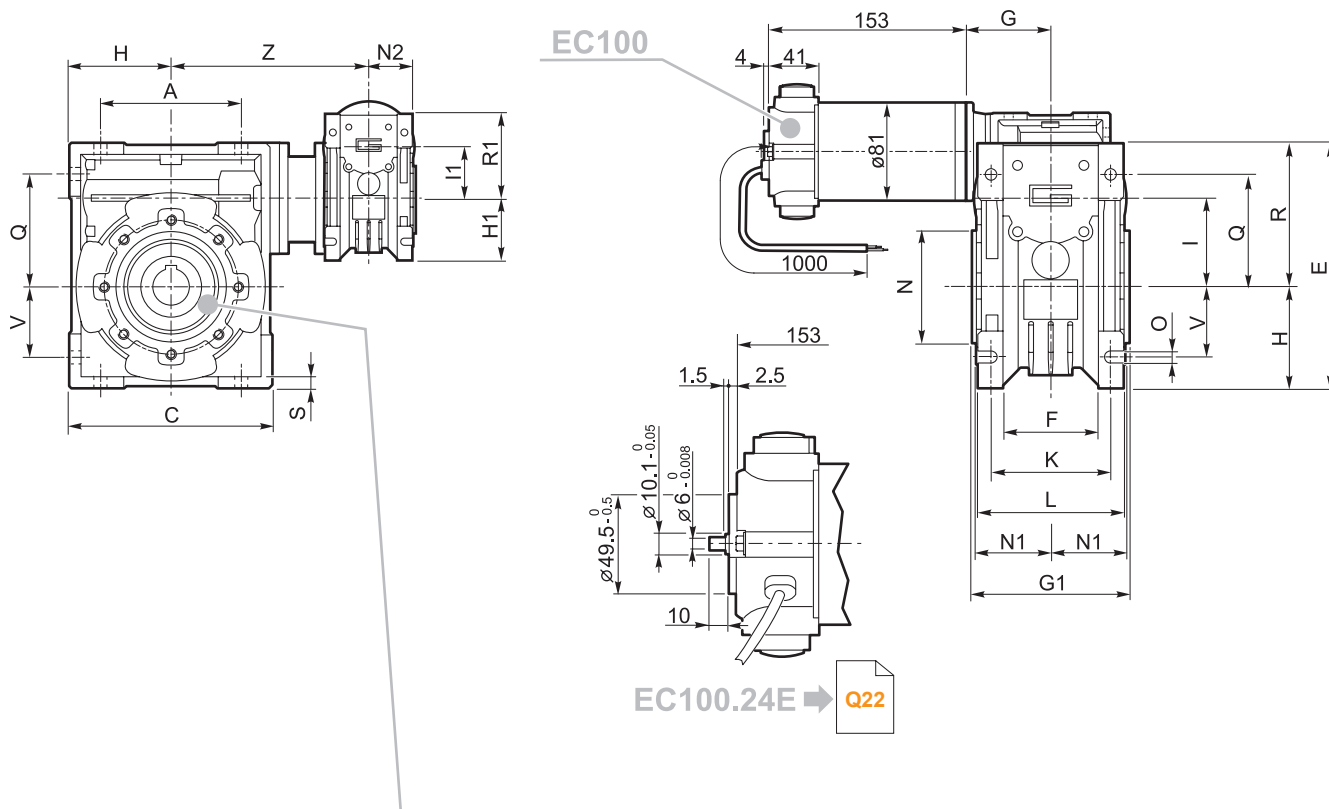

ECMM100/... F...
ECMM100/... FL
ECMM100/... FB

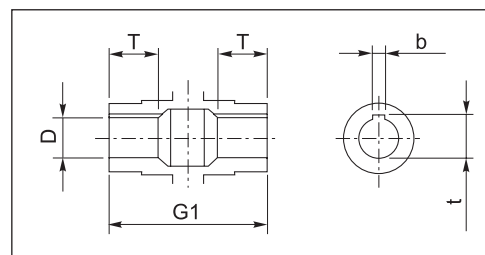

Albero lento cavo / Hollow output shaft

Motori / Motors IP66

→ **I4**

Freno / Brake

→ **H23**

Encoder

→ **H24**



Dimensioni
Dimensions

CMM..U - CMM..F - CMM..FB - CMM..FL																	
	A	C	D _{H8}	E	F	G	G1	H	H1	I	I1	K	L	M	N _{h8}	N1	N2
026/040	70	100	18	121.5	43	47.5	78	50	34	40	26	60	71	75	60	36.5	21
026/050	80	120	25	144	49	47.5	92	60	34	50	26	70	85	85	70	43.5	21
030/040	70	100	18	121.5	43	55	78	50	40	40	30	60	71	75	60	36.5	29
030/050	80	120	25	144	49	55	92	60	40	50	30	70	85	85	70	43.5	29
030/063	100	144	25	174	67	55	112	72	40	63	30	85	104	95	80	53	29
040/070	110	160	28	195	64	70	120	80	50	70	40	90	104	115	95	57	35.5
040/075	120	172	28	205	72	70	120	86	50	75	40	90	112	115	95	57	36.5
040/090	140	208	35	238	74	70	140	103	50	90	40	100	130	130	110	67	36.5
050/110	170	252.5	42	295	—	80	155	127.5	60	110	50	115	144	165	130	74	43.5

CMM..U - CMM..F - CMM..FB - CMM..FL															
	O	P	Q	R	R1	S	T	V	Z	KE	a	b	t	Kg (*)	
026/040	6.5	87	55	71.5	49	6.5	26	35	91.5	M6x8(n.4)	45°	6	20.8	6.9	
026/050	8.5	98	64	84	49	7	30	40	100.5	M8x10(n.4)	45°	8	28.3	8.4	
030/040	6.5	87	55	71.5	57	6.5	26	35	122	M6x8(n.4)	45°	6	20.8	7.3	
030/050	8.5	98	64	84	57	7	30	40	132	M8x10(n.4)	45°	8	28.3	8.4	
030/063	8.5	110	80	102	57	8	36	50	145	M8x14(n.8)	45°	8	28.3	10.4	
040/070	9	130	91	115	71.5	9	40	55	160	M8x14(n.8)	45°	8	31.3	14.4	
040/075	11	140	93	119	71.5	10	40	60	165	M8x14(n.8)	45°	8	31.3	15.4	
040/090	13	160	102	135	71.5	11	45	70	182	M10x18(n.8)	45°	10	38.3	19	
050/110	14	200	125	167.5	84	14	50	85	225	M10x18(n.8)	45°	12	45.3	33.6	

(*) **Nota:** Il peso in kg si riferisce al motoriduttore ECMM 180 /...

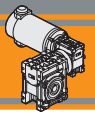
Note: The weight in kg is referred to the gearmotor ECMM 180 /...



Dimensioni

Dimensions

ECMM180/...U

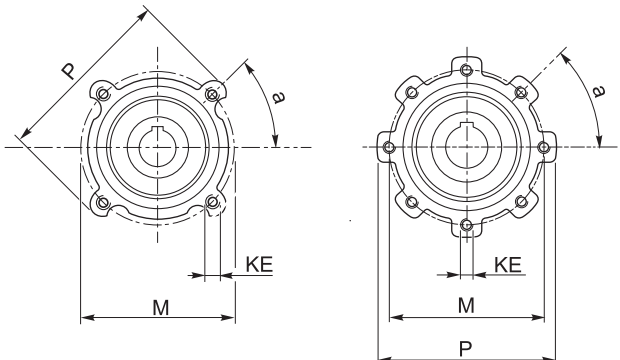
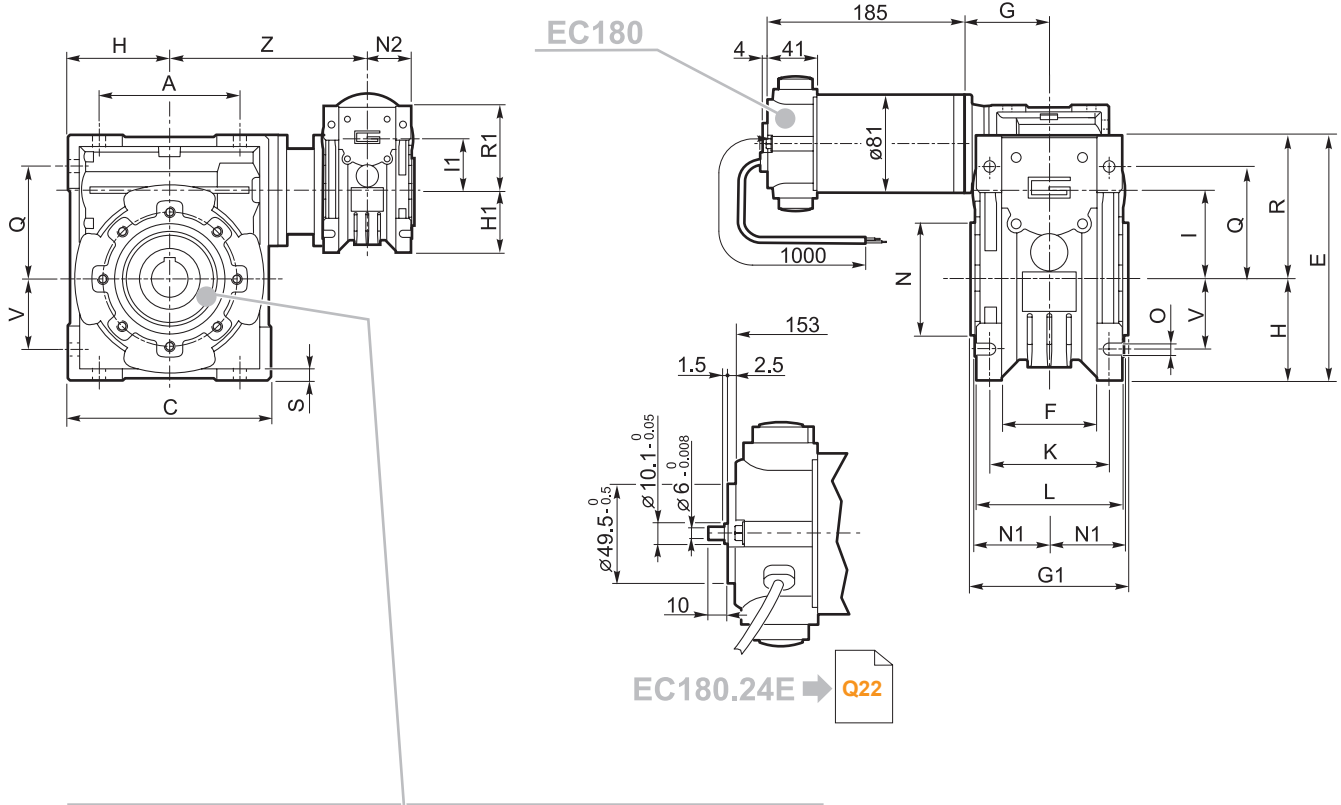

- ..026/040 ..026/050
- ..030/040 ..030/050
- ..030/063 ..040/070
- ..040/075 ..040/090
- ..050/110

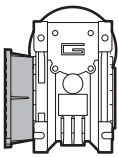
Q23 → 

ECMM180/... F
ECMM180/... FL
ECMM180/... FB

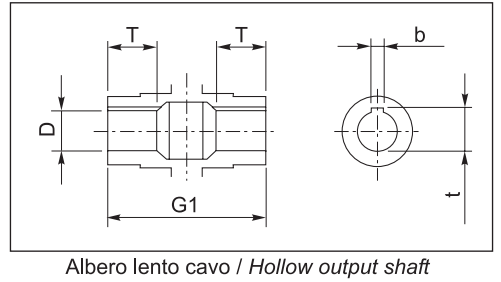

- Motori / Motors IP66 → **I6**
- Freno / Brake → **H23**
- Encoder → **H24**



Dimensioni

Dimensions

CMM..U - CMM..F - CMM..FB - CMM..FL																	
	A	C	D _{H8}	E	F	G	G1	H	H1	I	I1	K	L	M	N _{H8}	N1	N2
030/040	70	100	18	121.5	43	55	78	50	40	40	30	60	71	75	60	36.5	29
030/050	80	120	25	144	49	55	92	60	40	50	30	70	85	85	70	43.5	29
030/063	100	144	25	174	67	55	112	72	40	63	30	85	104	95	80	53	29
040/070	110	160	28	195	64	70	120	80	50	70	40	90	104	115	95	57	35.5
040/075	120	172	28	205	72	70	120	86	50	75	40	90	112	115	95	57	36.5
040/090	140	208	35	238	74	70	140	103	50	90	40	100	130	130	110	67	36.5
050/110	170	252.5	42	295	—	80	155	127.5	60	110	50	115	144	165	130	74	43.5

CMM..U - CMM..F - CMM..FB - CMM..FL															
	O	P	Q	R	R1	S	T	V	Z	KE	a	b	t	Kg (*)	
030/040	6.5	87	55	71.5	57	6.5	26	35	122	M6x8(n.4)	45°	6	20.8	8.2	
030/050	8.5	98	64	84	57	7	30	40	132	M8x10(n.4)	45°	8	28.3	9.3	
030/063	8.5	110	80	102	57	8	36	50	145	M8x14(n.8)	45°	8	28.3	11.3	
040/070	9	130	91	115	71.5	9	40	55	160	M8x14(n.8)	45°	8	31.3	15.3	
040/075	11	140	93	119	71.5	10	40	60	165	M8x14(n.8)	45°	8	31.3	16.3	
040/090	13	160	102	135	71.5	11	45	70	182	M10x18(n.8)	45°	10	38.3	19.9	
050/110	14	200	125	167.5	84	14	50	85	225	M10x18(n.8)	45°	12	45.3	34.5	

(*) **Nota:** Il peso in kg si riferisce al motoriduttore ECMM 250 /...
Note: The weight in kg is referred to the gearmotor ECMM 250 /...



Dimensioni

Dimensions

ECMM250/...U

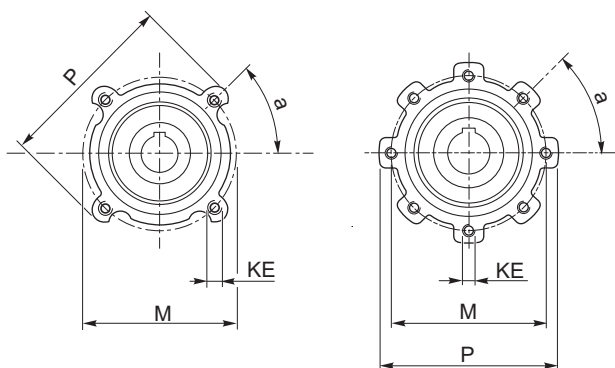
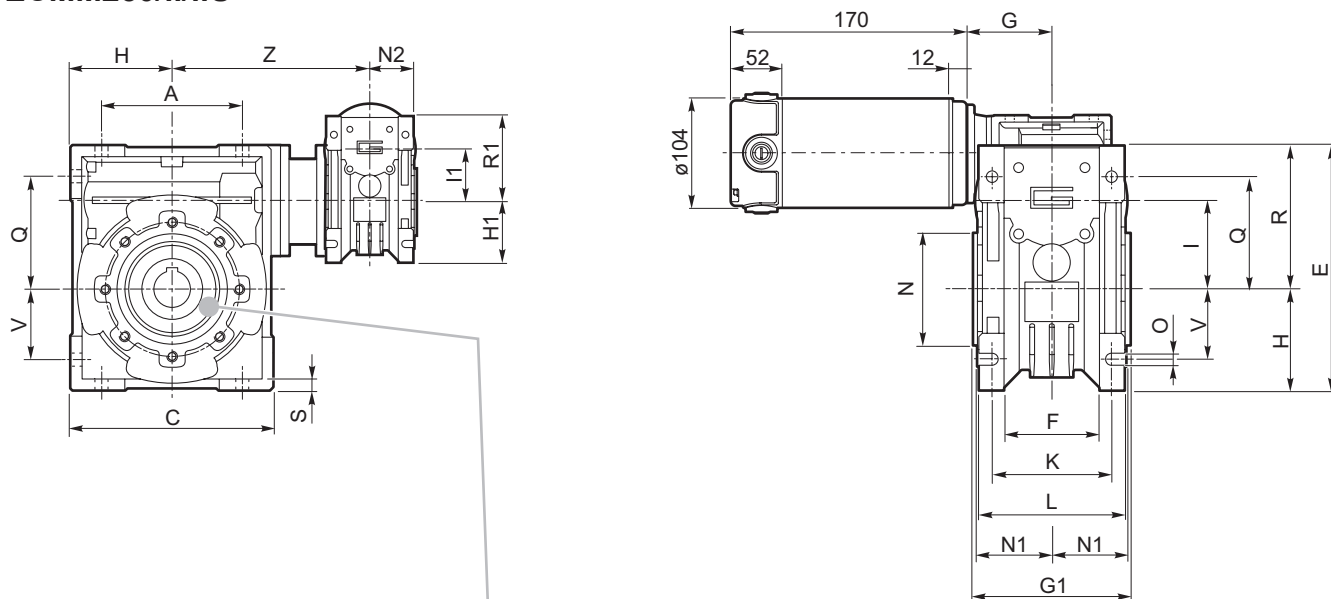

..030/040 ..030/050

..030/063 ..040/070
..040/075 ..040/090
..050/110

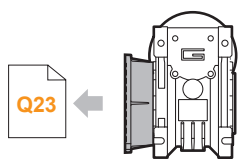

ECMM250/... F
ECMM250/... FL
ECMM250/... FB

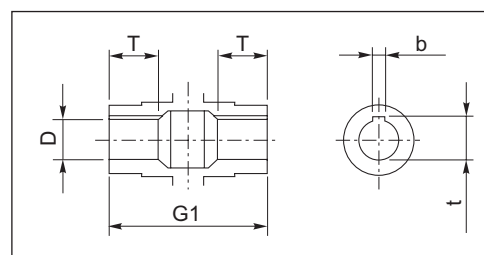

Albero lento cavo / Hollow output shaft

Motori / Motors IP66



Dimensioni
Dimensions

CMM..U - CMM..F - CMM..FB - CMM..FL																	
	A	C	D _{H8}	E	F	G	G1	H	H1	I	I1	K	L	M	N _{H8}	N1	N2
030/040	70	100	18	121.5	43	55	78	50	40	40	30	60	71	75	60	36.5	29
030/050	80	120	25	144	49	55	92	60	40	50	30	70	85	85	70	43.5	29
030/063	100	144	25	174	67	55	112	72	40	63	30	85	104	95	80	53	29
040/070	110	160	28	195	64	70	120	80	50	70	40	90	104	115	95	57	35.5
040/075	120	172	28	205	72	70	120	86	50	75	40	90	112	115	95	57	36.5
040/090	140	208	35	238	74	70	140	103	50	90	40	100	130	130	110	67	36.5
050/110	170	252.5	42	295	—	80	155	127.5	60	110	50	115	144	165	130	74	43.5
063/130	200	292.5	45	335	—	95	170	147.5	72	130	63	120	155	215	180	81	53

CMM..U - CMM..F - CMM..FB - CMM..FL															
	O	P	Q	R	R1	S	T	V	Z	KE	a	b	t	Kg (*)	
030/040	6.5	87	55	71.5	57	6.5	26	35	122	M6x8(n.4)	45°	6	20.8	9.2	
030/050	8.5	98	64	84	57	7	30	40	132	M8x10(n.4)	45°	8	28.3	10.3	
030/063	8.5	110	80	102	57	8	36	50	145	M8x10(n.8)	45°	8	28.3	12.3	
040/070	9	130	91	115	71.5	9	40	55	160	M8x14(n.8)	45°	8	31.3	16.3	
040/075	11	140	93	119	71.5	10	40	60	165	M8x14(n.8)	45°	8	31.3	17.3	
040/090	13	160	102	135	71.5	11	45	70	182	M10x18(n.8)	45°	10	38.3	20.9	
050/110	14	200	125	167.5	84	14	50	85	225	M10x18(n.8)	45°	12	45.3	35.5	
063/130	16	250	140	187.5	102	15	60	100	245	M12x21(n.8)	45°	14	48.8	60.3	

(*) **Nota:** Il peso in kg si riferisce al motoriduttore ECMM 350 /...

Note: The weight in kg is referred to the gearmotor ECMM 350 /...



Dimensioni

Dimensions

ECMM350/...U

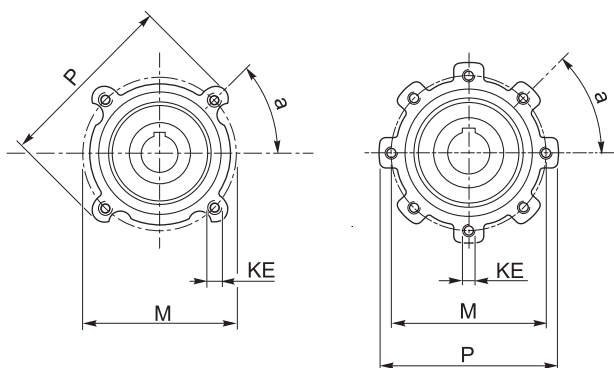
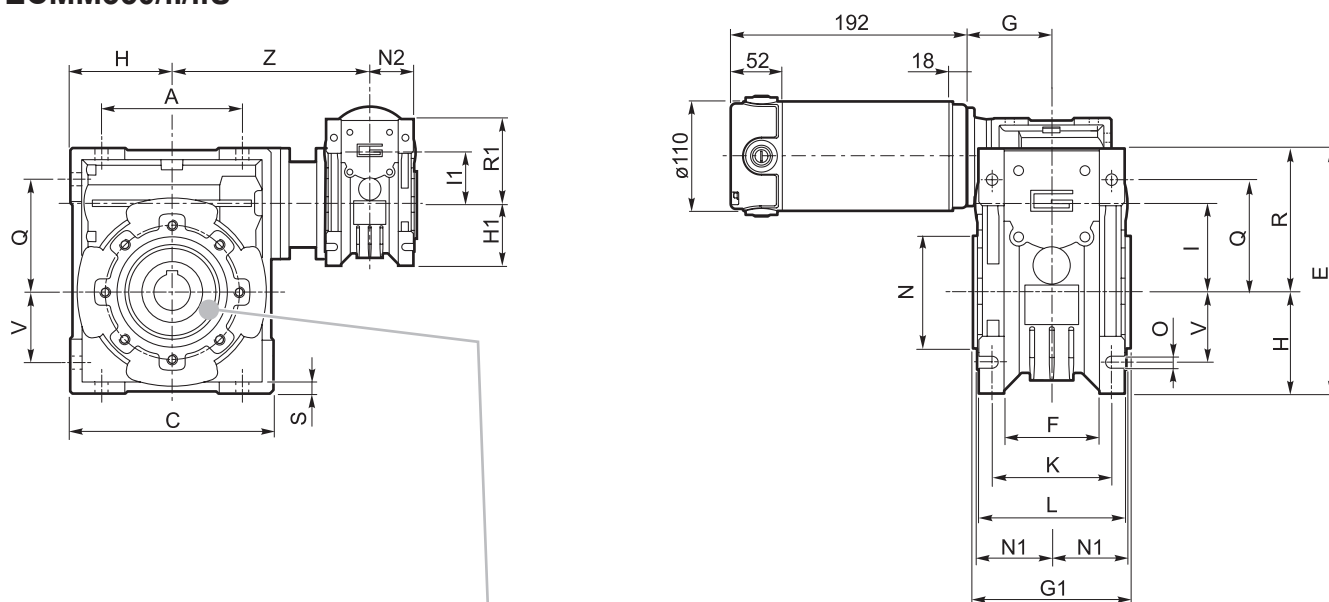

..030/040 ..030/050

..030/063 ..040/070
..040/075 ..040/090
..050/110 ..063/130

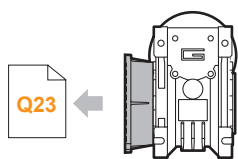

ECMM350/... F
ECMM350/... FL
ECMM350/... FB

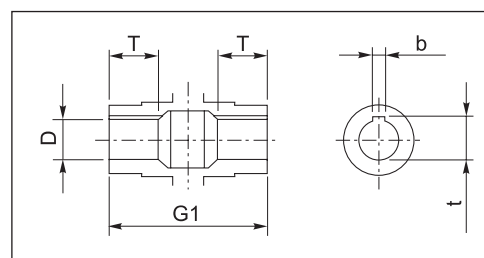

Albero lento cavo / Hollow output shaft

Motori / Motors IP66 → **I10**

Freno / Brake → **H23**

Dimensioni
Dimensions

CMM..U - CMM..F - CMM..FB - CMM..FL																	
	A	C	D _{H8}	E	F	G	G1	H	H1	I	I1	K	L	M	N _{H8}	N1	N2
040/070	110	160	28	195	64	70	120	80	50	70	40	90	104	115	95	57	35.5
040/075	120	172	28	205	72	70	120	86	50	75	40	90	112	115	95	57	36.5
040/090	140	208	35	238	74	70	140	103	50	90	40	100	130	130	110	67	36.5
050/110	170	252.5	42	295	—	80	155	127.5	60	110	50	115	144	165	130	74	43.5
063/130	200	292.5	45	335	—	95	170	147.5	72	130	63	120	155	215	180	81	53

CMM..U - CMM..F - CMM..FB - CMM..FL															
	O	P	Q	R	R1	S	T	V	Z	KE	a	b	t	Kg (*)	
040/070	9	130	91	115	71.5	9	40	55	160	M8x14(n.8)	45°	8	31.3	18.3	
040/075	11	140	93	119	71.5	10	40	60	165	M8x14(n.8)	45°	8	31.3	19.3	
040/090	13	160	102	135	71.5	11	45	70	182	M10x18(n.8)	45°	10	38.3	22.7	
050/110	14	200	125	167.5	84	14	50	85	225	M10x18(n.8)	45°	12	45.3	37.3	
063/130	16	250	140	187.5	102	15	60	100	245	M12x21(n.8)	45°	14	48.8	62.1	

(*) **Nota:** Il peso in kg si riferisce al motoriduttore ECMM 600 /...

Note: The weight in kg is referred to the gearmotor ECMM 600 /...



Dimensioni

Dimensions

ECMM600/...U

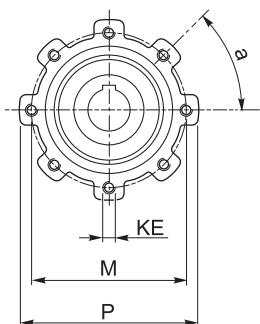
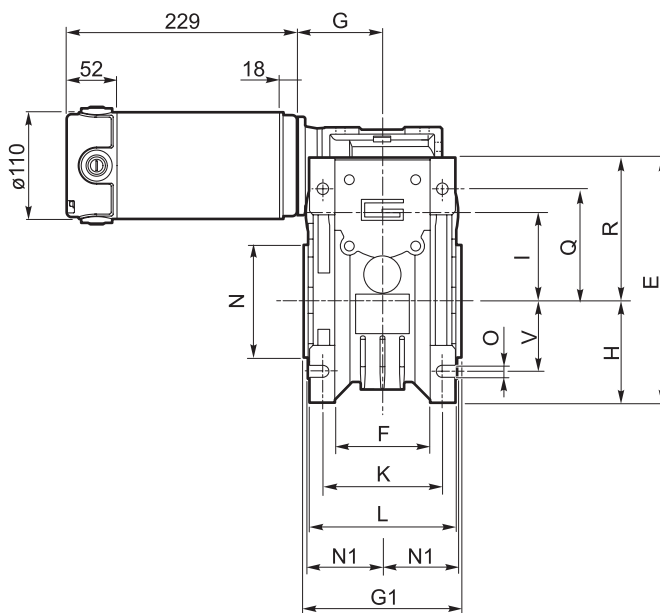
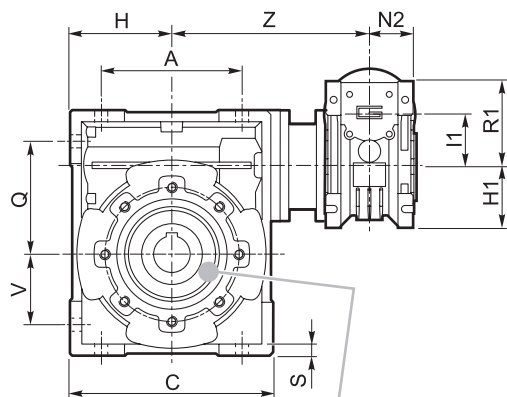

..040/070 ..040/075
..040/090 ..050/110
..063/130

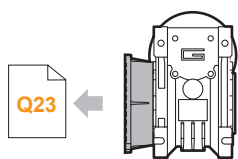

ECMM600/... F
ECMM600/... FL
ECMM600/... FB

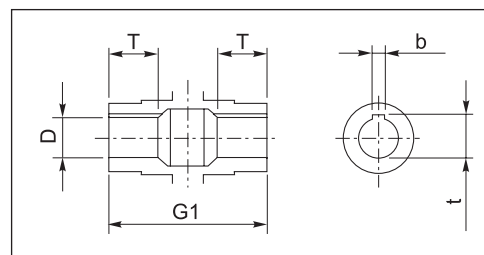

Albero lento cavo / Hollow output shaft

Motori / Motors IP66

→ I12

Freno / Brake

→ H23

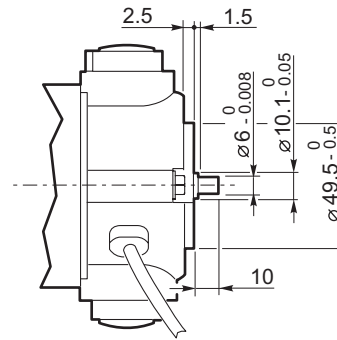
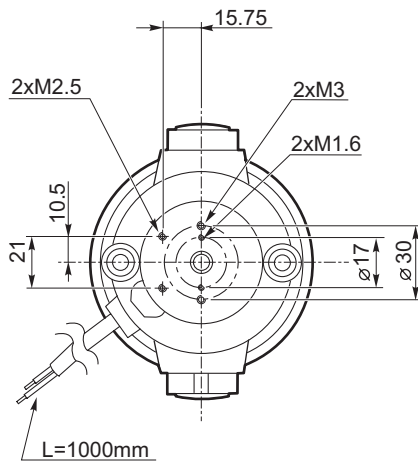
**Dimensioni****Dimensions****EC100.24E**
EC180.24E



Dimensioni

Dimensions

ECMM.../... F... Flange uscita / Output flanges

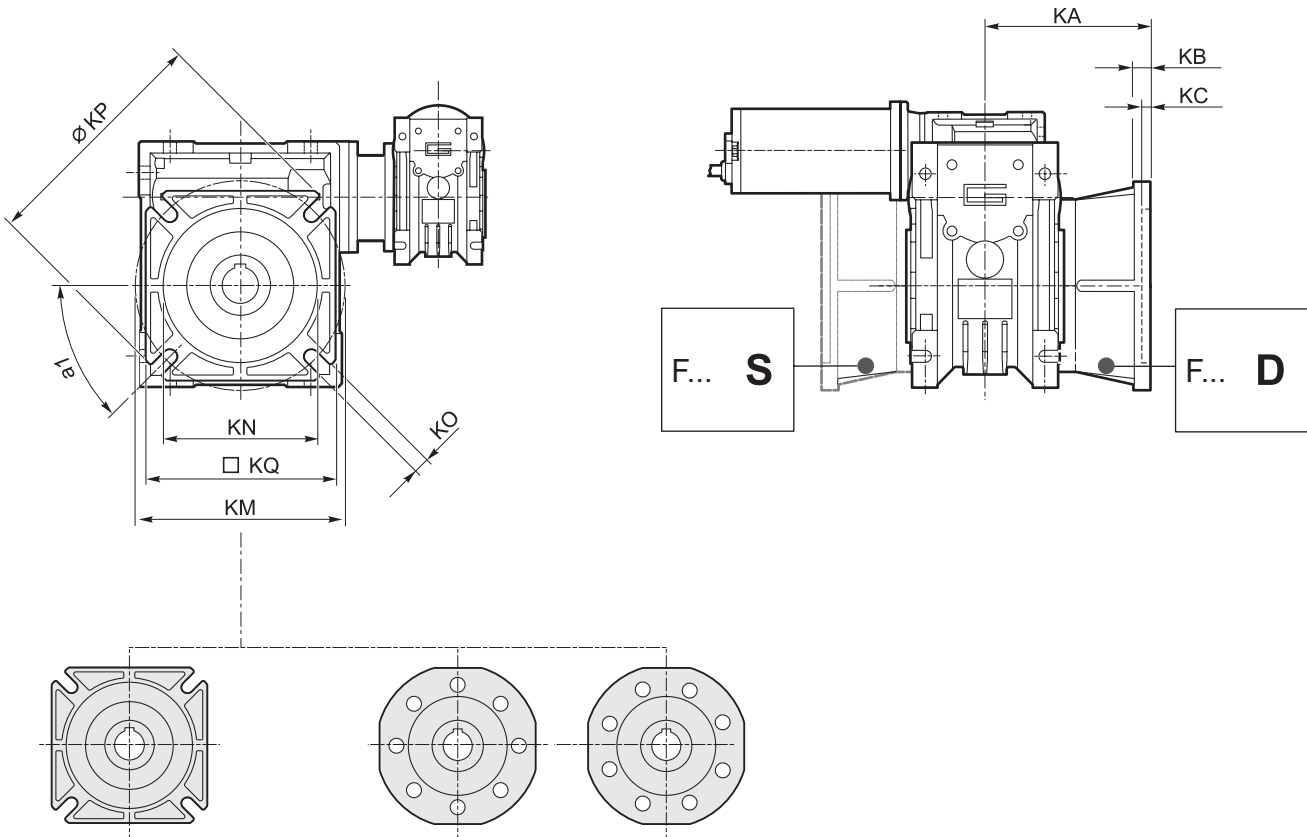

CMM..F...

(../026 - ../030 - ../040 - ../050
../063 - ../070 - ../075 - ../090)

CMM..F

(../110) (../130)

	CMM..F								CMM..F28						CMM..F30										
	a1	KA	KB	KC	KM	KN _{H8}	KO	KP	KQ	KA	KB	KC	KM	KN _{H8}	KO	KP	KQ	KA	KB	KC	KM	KN _{H8}	KO	KP	KQ
026/026 (D11)	45°	45	6	4.5	55-69	40	6.5(n.4)	75	70	44	6.5	5	56-64	40	6.5	70	60	48	6.5	5	68	50	6.5	80	70
026/026																									
026/026 (D14)																									

	CMM..F								CMM..FB						CMM..FL										
	a1	KA	KB	KC	KM	KN _{H8}	KO	KP	KQ	KA	KB	KC	KM	KN _{H8}	KO	KP	KQ	KA	KB	KC	KM	KN _{H8}	KO	KP	KQ
026/030	45°	54.5	6	4	68	50	6.5(n.4)	80	70	—	—	—	—	—	—	—	—	—	—	—	—	—	—	—	—
026/040	45°	67	7.5	4.5	80-95	60	9(n.4)	110	95	80	8.5	5	115-125	95	9.5(n.4)	140	112	97	7.5	4.5	80-95	60	9(n.4)	110	95
030/040																									
026/050	45°	90	9	5	90-110	70	11(n.4)	125	110	89	9	5	130-145	110	9.5(n.4)	160	132	120	9	5	90-110	70	11(n.4)	125	110
030/050																									
030/063	45°	82	10	6	150-160	115	11(n.4)	180	142	98	10	5	165-180	130	11(n.4)	200	112	112	10	6	150-160	115	11(n.4)	180	142
040/070	45°	107	13	6	165-180	130	14(n.4)	200	170	—	—	—	—	—	—	—	—	—	—	—	—	—	—	—	—
040/075	45°	111	13	6	165-180	130	14(n.4)	200	170	—	—	—	—	—	—	—	—	—	—	—	—	—	—	—	—
040/090	45°	111	13	6	175-190	152	14(n.4)	210	200	—	—	—	—	—	—	—	—	—	—	—	—	—	—	—	—
050/110	45°	131	15	6	230	170	14(n.8)	280	260	—	—	—	—	—	—	—	—	—	—	—	—	—	—	—	—
063/130	22.5°	140	15	6	255	180	16(n.8)	320	290	—	—	—	—	—	—	—	—	—	—	—	—	—	—	—	—

ECMM



Accessori

Accessories

Albero lento semplice e doppio

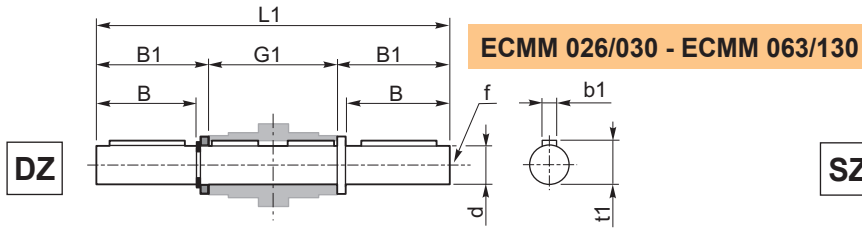

Single and double output shaft

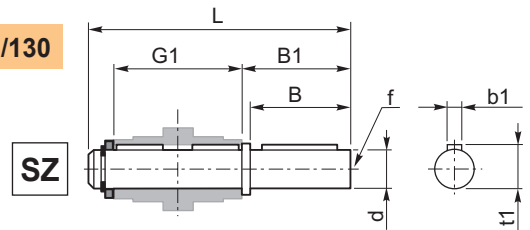

ECMM	d _{h7}	B	B1	G1	L	L1	f	b1	t1
026/030	14	30	32.5	63	102	128	M6	5	16
026/040	18	40	43	78	128	164	M6	6	20.5
030/040	25	50	53.5	92	153	199	M10	8	28
026/050	25	50	53.5	92	153	199	M10	8	28
030/050	25	50	53.5	92	153	199	M10	8	28
030/063	25	50	53.5	112	173	219	M10	8	28
040/070	28	60	63.5	120	192	247	M10	8	31
040/075	28	60	63.5	120	192	247	M10	8	31
040/090	35	80	84.5	140	234	309	M12	10	38
050/110	42	80	84.5	155	249	324	M16	12	45
063/130	45	80	85	170	265	340	M16	14	48.5

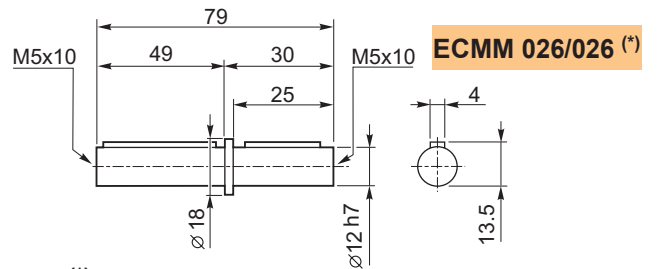

(*)
Nota: disponibile solo per cavo uscita Ø12
Note: available for output hollow shaft Ø12 only

Braccio di reazione

ECMM	K1	G	KG	KH	R
026/030	85	14	23	8	15
026/040	100	14	31	10	18
030/040	100	14	38	10	18
026/050	100	14	38	10	18
030/050	100	14	38	10	18
030/063	150	14	47.5	10	18
040/070	200	25	46.5	20	30
040/075	200	25	46.5	20	30
040/090	200	25	56.5	20	30
050/110	250	30	62	25	35
063/130	250	30	69	25	35

Torque arm

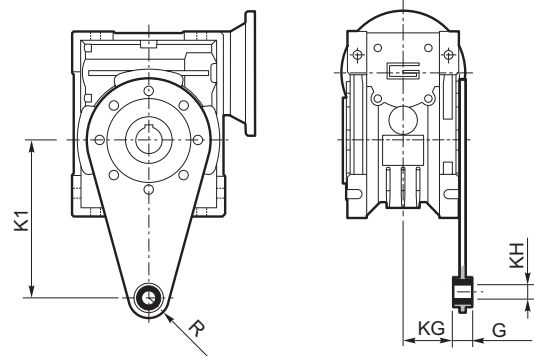

Opzioni

Options

VS1 - VS2 - Vite sporgente / Extended input shaft

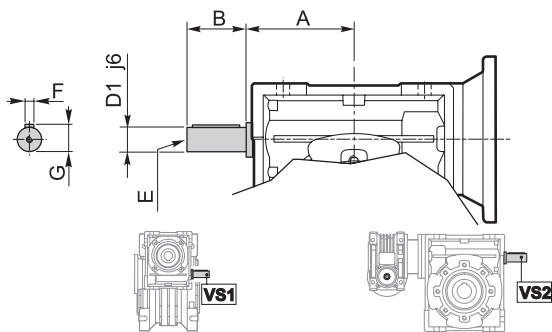

CMM	VS1						VS2					
	A	B	D ₁ j ₆	E	F	G	A	B	D ₁ j ₆	E	F	G
026/030	—	—	—	—	—	—	45	20	9	M4	3	10.2
026/040	—	—	—	—	—	—	53	23	11	M5	4	12.5
026/050	—	—	—	—	—	—	64	30	14	M6	5	16
030/040	45	20	9	M4	3	10.2	53	23	11	M5	4	12.5
030/050	45	20	9	M4	3	10.2	64	30	14	M6	5	16
030/063	45	20	9	M4	3	10.2	75	40	19	M6	6	21.5
040/070	53	23	11	M5	4	12.5	84	40	19	M6	6	21.5
040/075	53	23	11	M5	4	12.5	90	50	24	M8	8	27
040/090	53	23	11	M5	4	12.5	108	50	24	M8	8	27
050/110	64	30	14	M6	5	16	135	60	28	M10	8	31
063/130	75	40	19	M6	6	21.5	—	—	—	—	—	—

SC - Safety cover

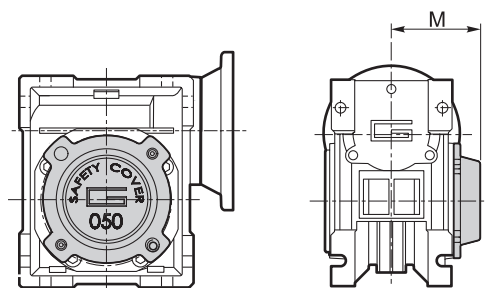

M	CM								
	30	40	50	63	70	75	90	110	130
—	47	54.5	62.5	73	79	79	94	102	117

Costruito su richiesta
Built on request

 **TRANSTECNO SRL**
HEADQUARTERS

Company subject to the management
and coordination of INTERPUMP GROUP SPA
Via Caduti di Sabbiuno, 11/D-E
40011 Anzola dell'Emilia (BO)
ITALY
T+39 051 64 25 811
F +39 051 73 49 43
sales@transtecno.com
www.transtecno.com

TRANSTECNO®
the modular gearmotor
MEMBER OF INTERPUMP GROUP

CATDCALU0521



 **HANGZHOU TRANSTECNO POWER TRANSMISSIONS CO LTD**
No.4 Xiuyan Road Fengdu Industry Zone
Pingyao Town Yuhang District
Hangzhou City, Zhejiang Province
311115 – CHINA
T +86 571 86 92 02 60
F +86 571 86 92 18 10
info-china@transtecno.cn
www.transtecno.cn

 **MA TRANSTECNO S.A.P.I. DE C.V.**
Av. Mundial # 176, Parque Industrial
JM Apodaca, Nuevo León,
C.P. 66600 – MÉXICO
T +52 8113340920
info@transtecno.com.mx
www.transtecno.com.mx

 **TRANSTECNO IBÉRICA THE MODULAR GEARMOTOR, S.A.**
Carrer de la Ciència, 45
08840 Viladecans (Barcelona) - SPAIN
T +34 931 598 950
info@transtecno.es
www.transtecno.es

 **TRANSTECNO B.V.**
De Stuwdam, 43
3815 KM Amersfoort - NETHERLANDS
T +31(0) 33 45 19 505
F +31(0) 33 45 19 506
info@transtecno.nl
www.transtecno.nl

www.transtecno.com

 **TRANSTECNO AANDRIJFTECHNIEK B.V.**
De Stuwdam 43
3815 KM Amersfoort - NETHERLANDS
T +31 (0) 33 20 4 7 006
info@transtecnoaandrijftechniek.nl
www.transtecnoaandrijftechniek.nl

 **TRANSTECNO USA**
8 Creek Parkway,
Boothwyn PA 19061-8136
UNITED STATES
T +1 (610) 4970154
F +1 (610) 497 6085

14561 Fryelands Blvd SE
Monroe, WA 98272 - UNITED STATES
T +1 360-863-1300
F +1 360-863-1303
usaoffice@transtecno.com
www.transtecno.com

 **TRANSTECNO CANADA**
51 B Caldari Road Unit 10
Vaughan, ON L4K 4G3 - CANADA
T +1 905 761 0762
F +1 905 761 9265
canadaoffice@transtecno.com
www.transtecno.com

 **TRANSTECNO CHILE-PERU**
Av. Los Libertadores 41
Parque Industrial - Los Libertadores 16.500
Santiago, Colina - CHILE
T +56 2 29633870

Carretera Panamericana Sur KM 29.5,
Interior 1-3, Z.I. Lurin - PERU
T +51 1 3546259 / + 51 1 3434231
chileoffice@transtecno.com
www.transtecno.com

 **SALES OFFICE BRAZIL**
Rua Dr. Freire Alemão 155 / 402 - CEP. 90450-060
Auxiliadora Porto Alegre RS - BRAZIL
T +55 51 3251 5447
F +55 51 3251 5447
M +55 51 811 45 962
braziloffice@transtecno.com
www.transtecno.com.br

 **SALES OFFICE OCEANIA**
44 Northview drive, Sunshine west 3020
Victoria - AUSTRALIA
T +61 03 9312 4722
F +61 03 9312 4714
M +61 0438060997
oceaniaoffice@transtecno.com
www.transtecno.com.au

 **SALES OFFICE INDIA**
Woodbine 2003/04, Everest World
Kolshet Road, Thane west Mumbai 400607
INDIA
T +91 982 061 46 98
indiaoffice@transtecno.com
www.transtecno.com

 **SALES OFFICE SOUTH KOREA**
772-41, Bongdong-ro, Bongdong-eup, Wanju-goon
Chonbuk, 55313
SOUTH KOREA
T +82 70 8867 8897
F +82 504 199 2107
M +82 10 5094 2107
koreaoffice@transtecno.com
www.transtecno.com