

# SS-EC

## EtherCAT Step-Servo Drive

- CoE(CiA 402 drive profile)
- PP, PV, TQ, CSP, CSV, HM modes supported
- MOONS' own Q mode supported
- Intelligent built-in controller
- Enhanced motor, optimized design, long life
- Efficient, smooth, accurate, fast
- Low vibration, low noise, low heat



EtherCAT<sup>®</sup>



**MOONS'**  
*moving in better ways*

The SS-EC is a member of the Step-Servo family equipped with a built-in EtherCAT communication interface. This drive can operate as a standard EtherCAT slave using CANopen over EtherCAT (CoE). It is designed to work with various MOONS' step servo motors.

- Programmable, digital step-servo drive and motor package
- Operates from a 24 to 70 volt DC power supply
- CANopen over EtherCAT (CoE) with full support of CiA402. Based on the widely used 100BASE-TX cabling system and with a baud rate of 100Mbps full-duplex, EtherCAT enables high speed and highly reliable communication.
- Supported modes: Profile Position, Profile Velocity, Profile Torque, Cyclic Synchronous Position, Cyclic Synchronous Velocity and Homing; as well as MOONS' own Q mode
- Dual port EtherCAT communication
- USB port for configuration
- Encoder resolution: 20000 counts/rev for AM17/23/24/34SS motor, 4096 counts/rev for AM11SS motor
- SS03-EC output current: continuous 3A, boost 4.5A
- SS05-EC output current: continuous 5A, boost 7.5A
- SS10-EC output current: continuous 10A, boost 15A
- 8 optically isolated digital inputs, 5-24VDC high level voltage
- 4 optically isolated digital outputs, max 30V/100mA sink or source current
- 2 analog inputs, can be configured to 0-5V, 0-10V,  $\pm 5V$  or  $\pm 10V$  signal ranges
- Differential encoder signal output (AOUT+/-, BOUT+/-, ZOUT+/-), 26C31 line driver, 20mA sink or source current
- Auxiliary power supply for keep alive operation
- Front panel with 4 keys and 5 digital LED display for setting parameters
- STO function (Safe Torque Off)

**■ Closed Loop**

- Very tight position and velocity control for the most demanding applications.
- Robust servo loops that tolerate wide fluctuation in load inertia and frictional loading.
- Precise positioning to within  $\pm 1$  count using high resolution encoder (20000 counts/rev for AM17/23/24/34SS motor, 4096 counts/rev for AM11SS motor).

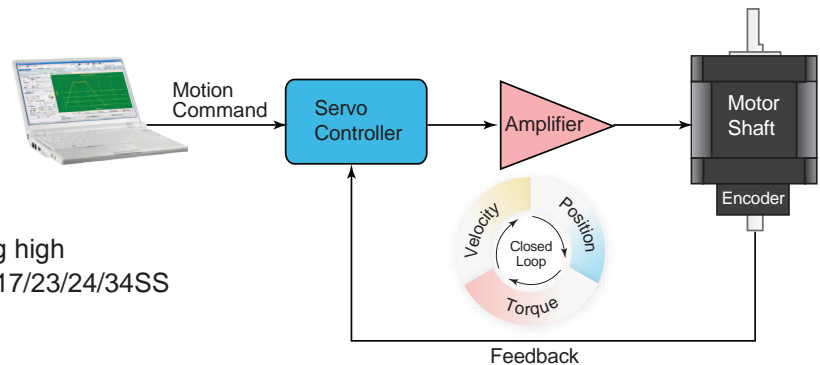

**■ Low Heating/High Efficiency**

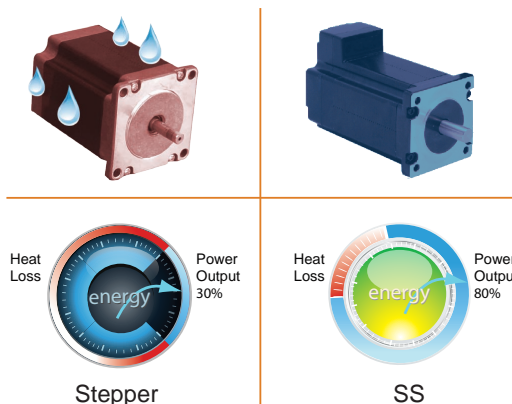

- The SS-EC uses only the current required by the application, generating minimum heat output.
- When the motor is not moving, the current can be nearly zero resulting in extremely low heat output.
- Being able to use almost 100% of the available torque allows for more efficient operation and may allow a smaller motor size.

■ **Smooth & Accurate**

- Space vector current control with a high resolution encoder gives smooth and quiet operation, especially at low speeds - a feature not found with traditional stepper motors.
- High stiffness due to the nature of the stepper motor combined with the highly responsive servo control results in accurate position control both while running and when standing still.

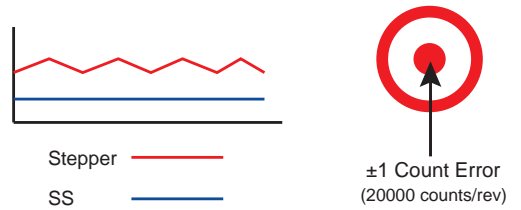

■ **Fast Response**

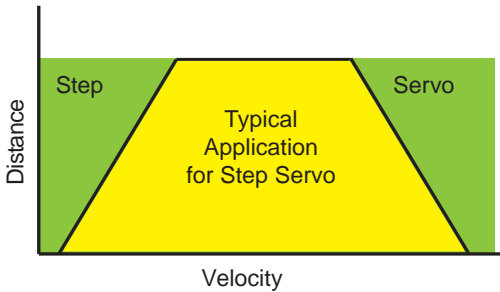

- When performing fast point-to-point moves, the high torque output and advanced servo control provides a very responsive system far exceeding what can be done with a conventional stepper system.

■ **High Torque**

- Because the **Step-Servo** operates in full servo mode, all the available torque of the motor can be used.
- The motor can provide as much as 50% more torque in many applications. High torque capability often eliminates the need for gear reduction.
- Boost torque capability can provide as much as 50% more torque for short, quick moves.

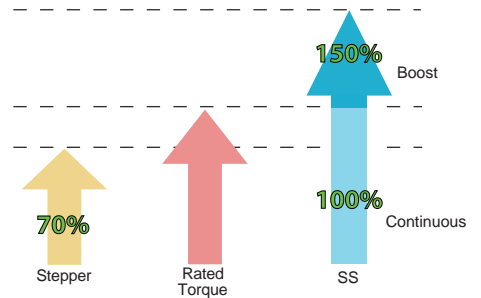

■ **Motion Monitoring**

- For difficult control situations where performing a precise move is necessary, the **Step-Servo Quick Tuner** software provides an easy to use interface for performing and monitoring the motion profile.
- Many common parameters such as Actual Speed or Position Error can be monitored to evaluate system performance.
- The monitoring is interactive with the servo tuning capability so that optimum performance can be achieved.

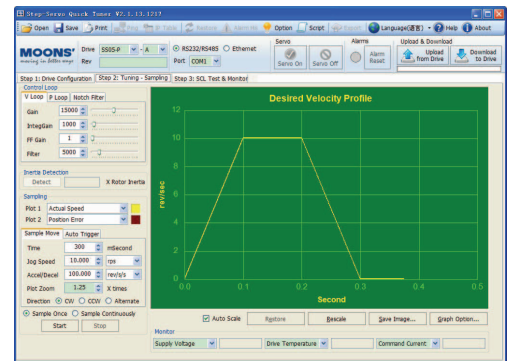

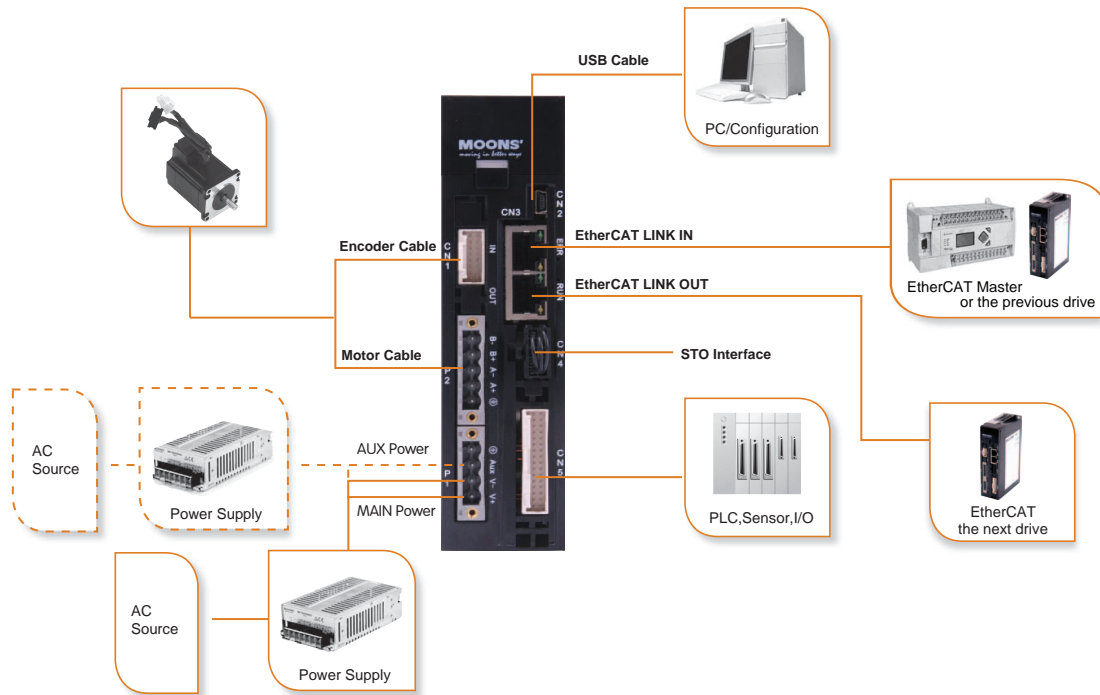

■ Specifications

Power Amplifier	
Amplifier Type	Dual H-Bridge, 4 Quadrant
Current Control	4 state PWM at 20 KHz
Output Current	SS03 Maximum continuous current 3A, boost current 4.5A (for 1.5s) Drive auto-set the current limitation according to the attached motor SS05 Maximum continuous current 5A, boost current 7.5A (for 1.5s) Drive auto-set the current limitation according to the attached motor SS10 Maximum continuous current 10A, boost current 15A (for 1.5s) Drive auto-set the current limitation according to the attached motor
Power Supply	External 24 - 70 volt DC power supply required Absolute maximum input voltage range 18 - 75 VDC
Auxiliary Power Supply	External 12 - 48 volt DC power supply required
Protection	Over-voltage, under-voltage, over-temp, over-current, short circuit
Controller	
Micro-step Resolution	Software selectable from 200 to 51200 steps/rev in increments of 2 steps/rev
Encoder Resolution	20000 counts/rev for AM17/23/24/34SS motor; 4096 counts/rev for AM11SS motor
Speed Range	Speeds up to 3600 rpm
Filters	Programmable hardware digital noise filter, software noise filter, smoothing filter, PID filter, notch filter
Non-Volatile Storage	Configurations are saved in FLASH memory on-board the DSP
Supported Protocol	CoE (CiA 402 Drive profile)
Supported Modes	Profile Position, Profile Velocity, Profile Torque, Cyclic Synchronous Position, Cyclic Synchronous Velocity, Homing and MOONS' own Q mode
Synchronization	SM Event, DC SYNC Event
Digital Inputs	X1, X2, X3, X4: optically isolated, differential, 5-24VDC, minimum pulse width 250ns, maximum pulse frequency 2MHz X5, X6, X7, X8: optically isolated, single-ended input, 5 - 24 volts
Digital Output	Y1, Y2, Y3, Y4: optically isolated, open collector, 30 volts, 100 mA max, maximum pulse frequency 10 KHz
Analog Input	AIN1, AIN2: individually single-ended or together differential Input resolution 12-bit, software configured as 0-5 volts, 0-10 volts, $\pm 5$ volts or $\pm 10$ volts (AIN referenced to GND)
+5V Supply Output	+4.8 - 5 volts @ 100mA maximum
Communication	EtherCAT and mini USB for configuration
Environment	
Ambient Temperature	0 - 40°C (32 - 104°F) when mounted to a suitable heatsink
Humidity	90% non-condensing

■ **Dimensions**

👉 Visit [www.moonsindustries.com](http://www.moonsindustries.com) for 3D drawings

• Motor unit: mm

**AM11SS**

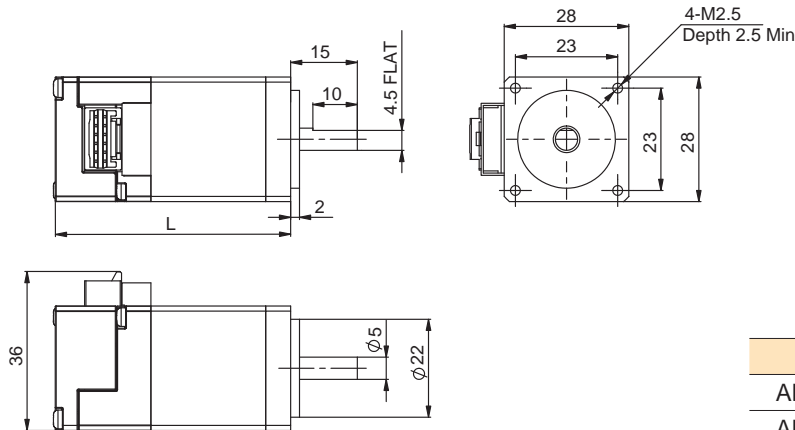

Model	L
AM11SS1DMA	43.8
AM11SS2DMA	52.9
AM11SS3DMA	64.1

**AM17SS-N**

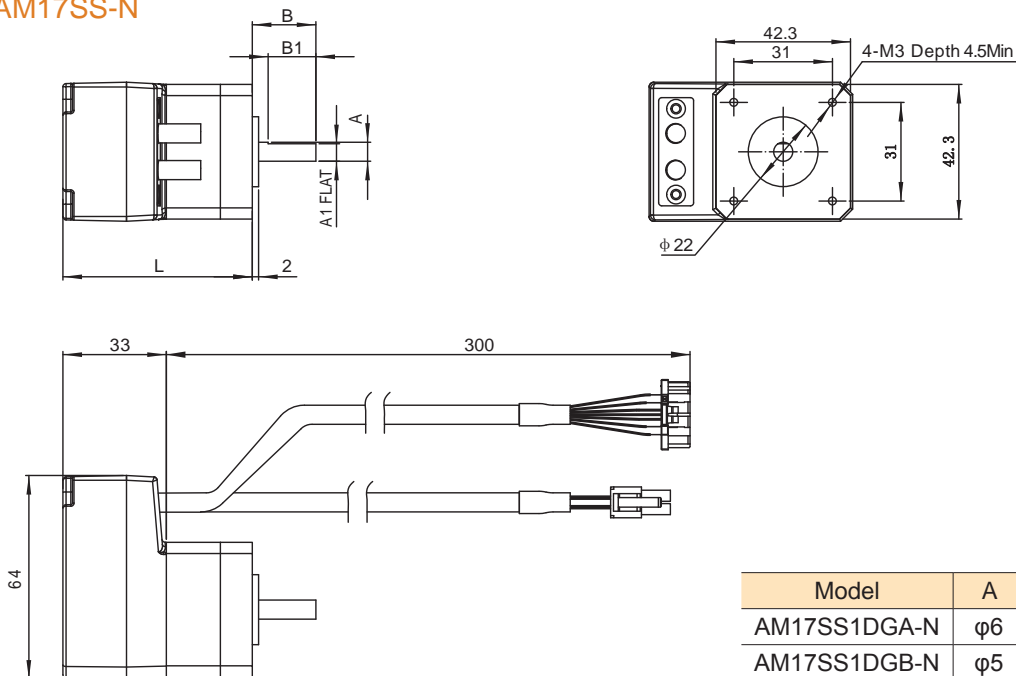

Model	A	A1	B	B1	L
AM17SS1DGA-N	φ6	5.5	20	15	59.5
AM17SS1DGB-N	φ5	4.5	24	15	59.5
AM17SS2DGA-N	φ6	5.5	20	15	65
AM17SS2DGB-N	φ5	4.5	24	15	65
AM17SS3DGA-N	φ6	5.5	20	15	73.5
AM17SS3DGB-N	φ5	4.5	24	15	73.5
AM17SS4DGA-N	φ6	5.5	20	15	89
AM17SS4DGB-N	φ5	4.5	24	15	89

**AM23SS-N**

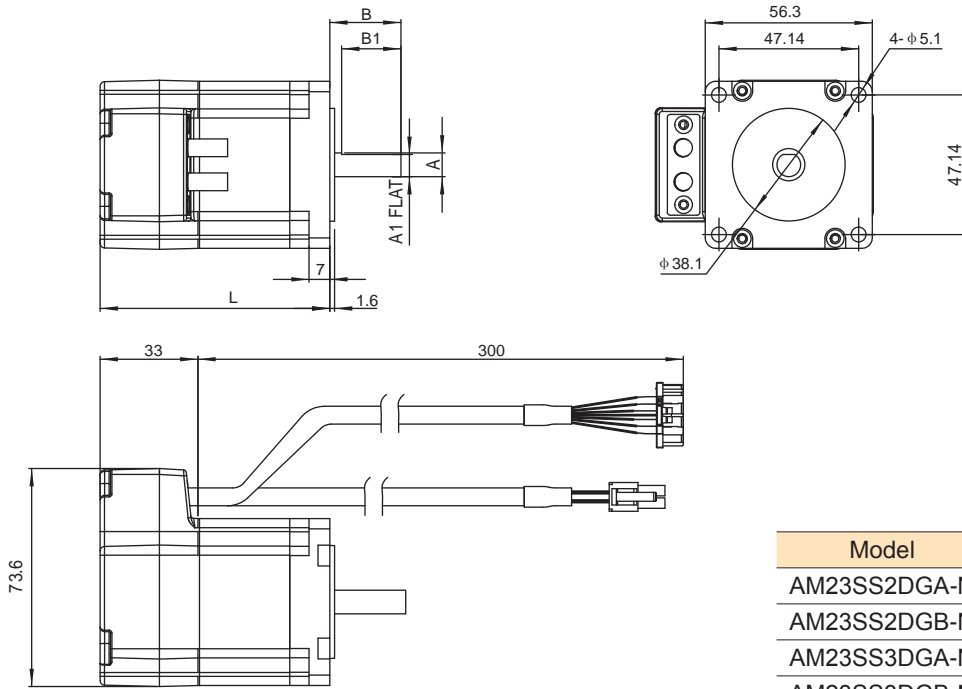

Model	A	A1	B	B1	L
AM23SS2DGA-N	φ8	7.5	24	20	77.5
AM23SS2DGB-N	φ6.35	5.85	20	15	77.5
AM23SS3DGA-N	φ8	7.5	24	20	99.5
AM23SS3DGB-N	φ6.35	5.85	20	15	99.5
AM23SS4DGA-N	φ8	7.5	24	20	102.5

**AM24SS-N**

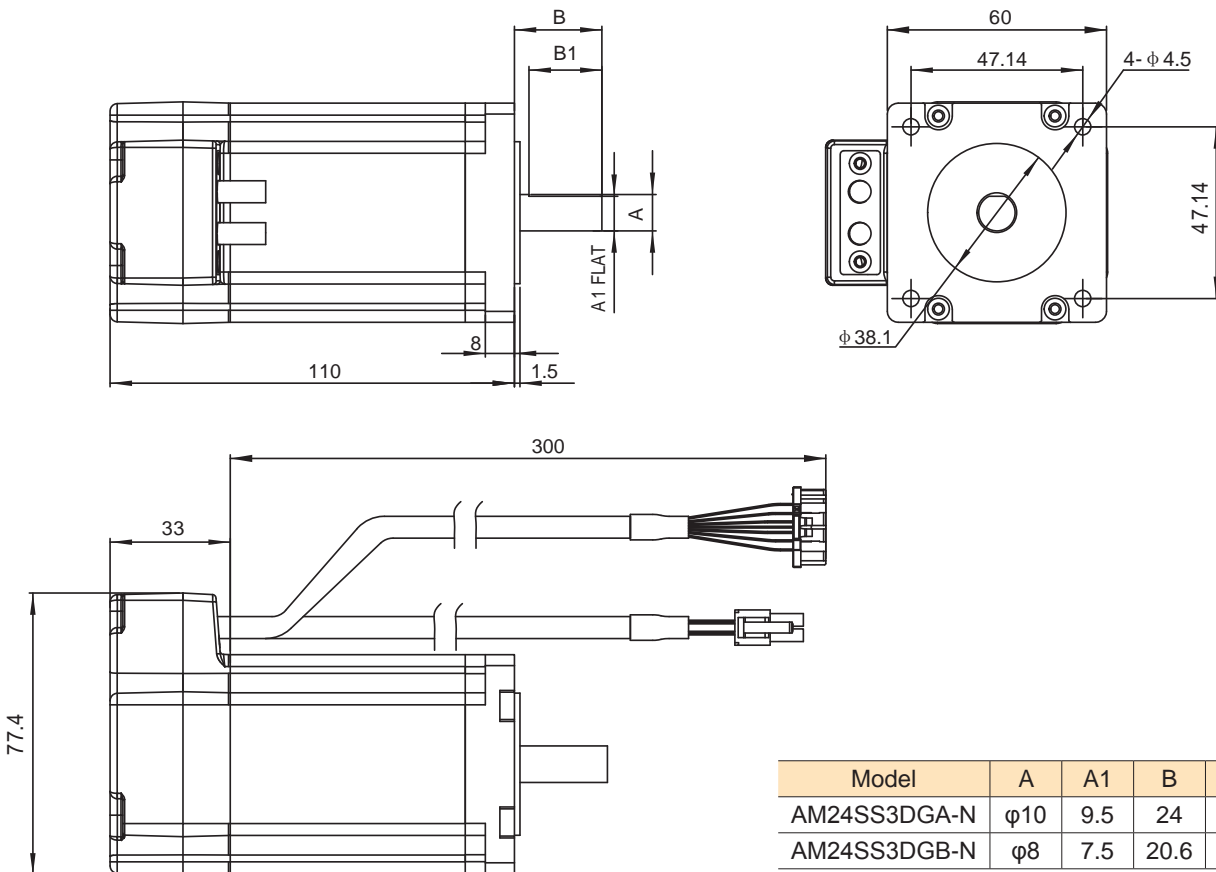

Model	A	A1	B	B1
AM24SS3DGA-N	φ10	9.5	24	20
AM24SS3DGB-N	φ8	7.5	20.6	15

AM34SS-N

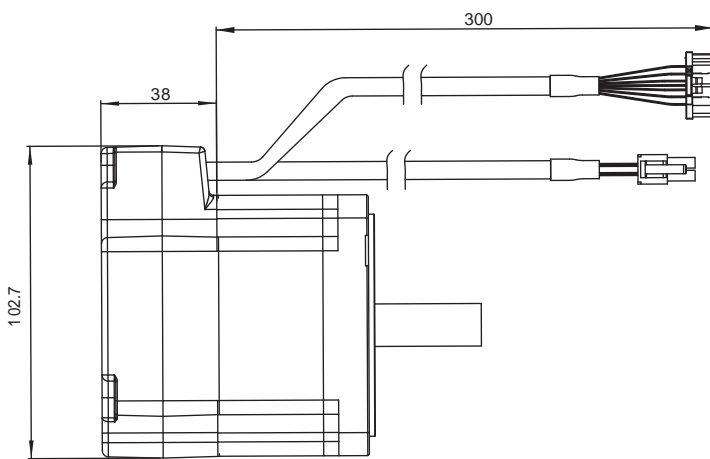
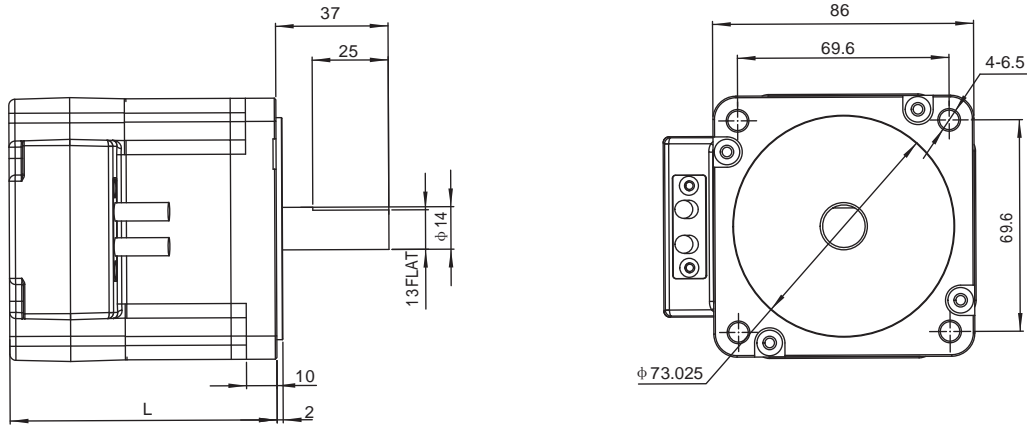

Model	L
AM34SS1DGA-N	88
AM34SS3DGA-N	117.5
AM34SS5DGA-N	147

• Drive unit: mm

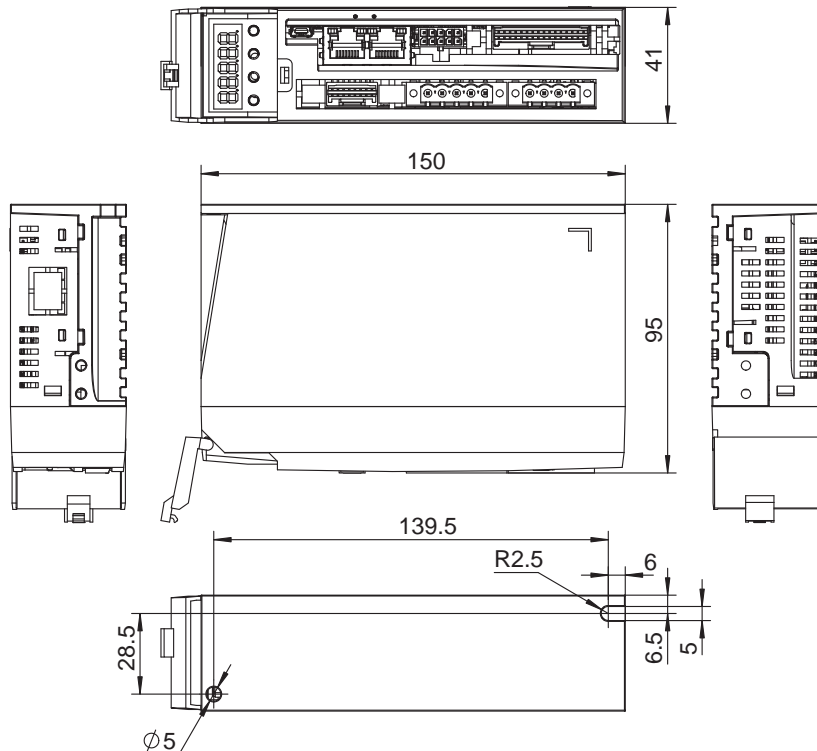

Motor Specifications

Motor Part Number	Matching Drive	Holding Torque N·m	Rotor Inertia g·cm <sup>2</sup>	Encoder Resolution counts/rev	Maximum Speed RPM	Mass g	Frame Size	Permissible Shaft Load (N)					Permissible Thrust Load
								Distance (L) from Shaft End (mm)					
								0	5	10	15	20	
AM11SS1DMA	SS03-EC-D	0.065	9	4096	3600	118	28mm	20	25	34	52	-	Less than the motor mass
AM11SS2DMA		0.08	12			168							
AM11SS3DMA		0.125	18			218							
AM17SS1DG□-N	SS03-EC-D or SS05-EC-D	0.3	38	20000	3600	390	42mm	35	44	58	85	-	
AM17SS2DG□-N		0.5	57			440							
AM17SS3DG□-N		0.6	82			520							
AM17SS4DG□-N	SS05-EC-D	0.75	123	20000	3600	760	56mm	63	75	95	130	190	
AM23SS2DG□-N		0.9	260			850							
AM23SS3DG□-N		1.5	460			1250							
AM23SS4DGA-N	SS10-EC-D	2.5	365	20000	3600	840	60mm	90	100	130	180	270	
AM24SS3DG□-N		2.5	900			1650							
AM34SS1DGA-N		3.5	915			2000							
AM34SS3DGA-N	SS10-EC-D	6.0	1480	20000	3600	3100	86mm	260	290	340	390	480	
AM34SS5DGA-N		8.0	2200			4200							

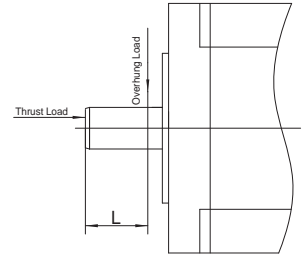

□□ A or B, refer to motor part numbering system

Torque Curves

AM11SS Series

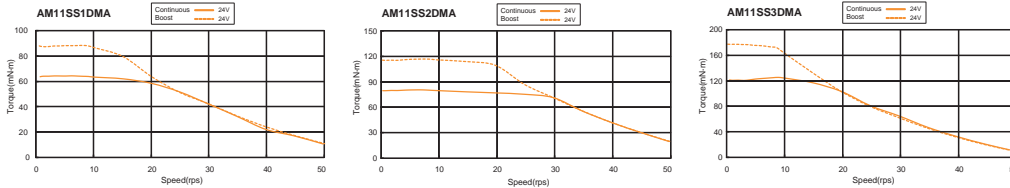

AM17SS Series

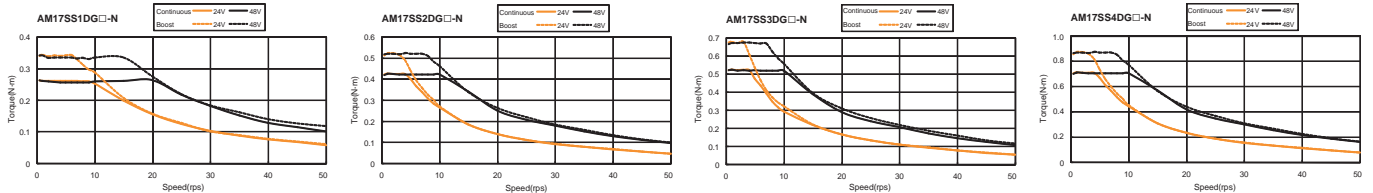

AM23SS Series

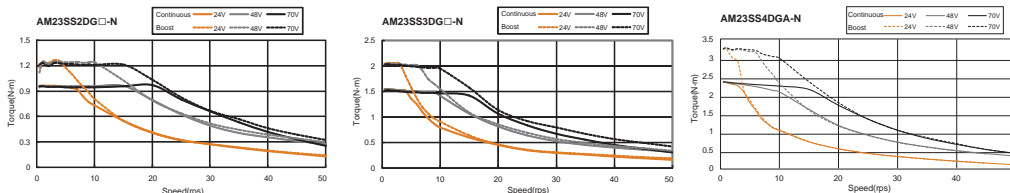

AM24SS Series

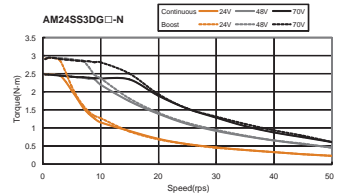

AM34SS Series

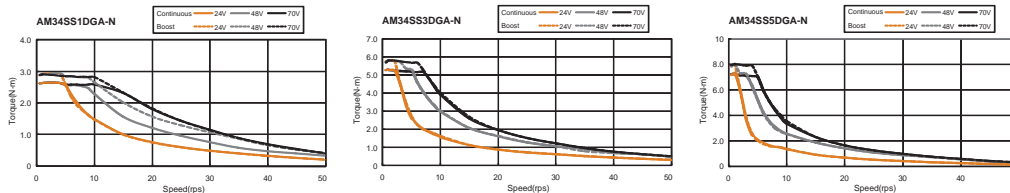



■ **Numbering System**

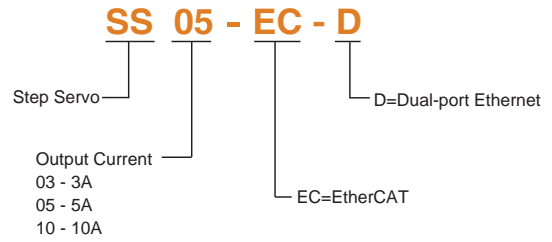
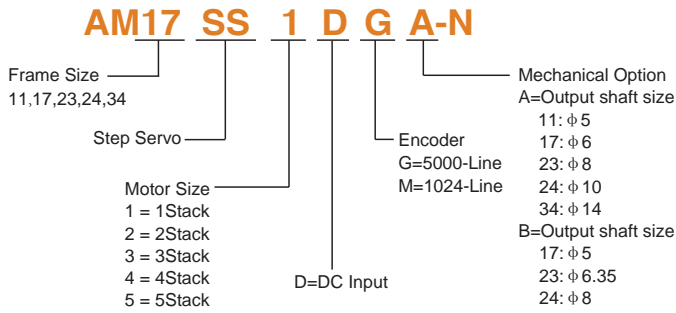

Note: AM17/23/24/34SS motors matching with SS-EC drive have -N suffix  
AM11SS motors matching with SS-EC drive DO NOT have -N suffix

■ **Optional Accessories (Sold separately)**

• I/O Cable

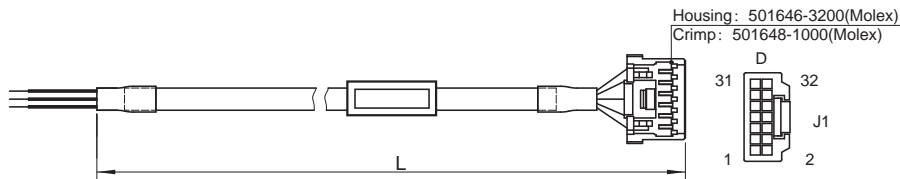

P/N	Length (L)
1117-200	2M

Wiring Diagram			
PIN (J1)	Color (Signal)	PIN (J1)	Color (Signal)
1	Blue/White (X1+)	17	NC
2	Blue/Black (X1-)	18	NC
3	Green/White (X2+)	19	Brown/White (Y1+)
4	Green/Black (X2-)	20	Brown/Black (Y1-)
5	Red (X3+)	21	Gray/White (Y2+)
6	Orange (X3-)	22	Gray/Black (Y2-)
7	Blue (X4+)	23	Purple/White (Y3+)
8	Purple (X4-)	24	Purple/Black (Y3-)
9	Yellow (X5)	25	Pink (Y4+)
10	Green (X6)	26	Yellow/Green (Y4-)
11	Brown (X7)	27	Red/White (AOUT+)
12	Gray (X8)	28	Red/Black (AOUT-)
13	Shield	29	Orange/White (BOUT+)
14	White (XCOM)	30	Orange/Black (BOUT-)
15	Black (GND)	31	Yellow/White (ZOUT+)
16	NC	32	Yellow/Black (ZOUT-)

• Motor Extension Cable between SS-EC drive and AM11SS motor

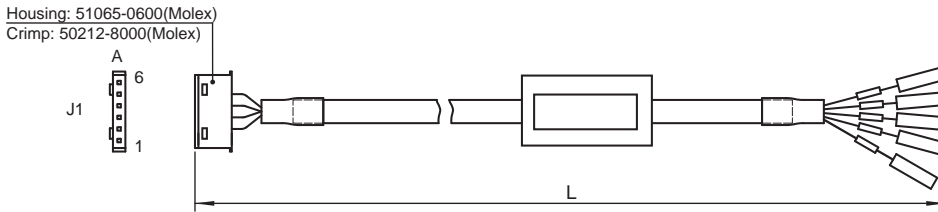

P/N	Length (L)
1127-100	1M
1127-300	3M
1127-500	5M
1127-1000	10M

Wiring Diagram	
PIN (J1)	Color (Signal)
1	Blue (B-)
3	Red (B+)
4	Green (A-)
6	Black (A+)

• Motor Extension Cable between SS-EC drive and AM17/23/24/34SS-N motor

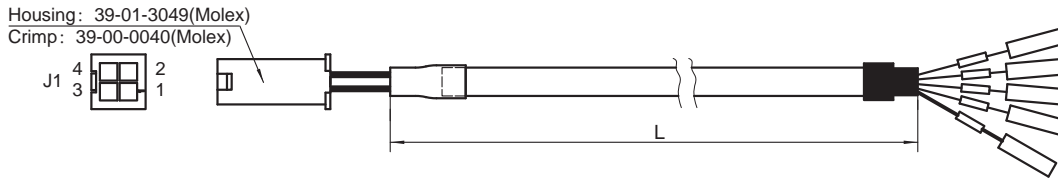

P/N	Length (L)
1114-100	1M
1114-300	3M
1114-500	5M
1114-1000	10M

Wiring Diagram	
PIN (J1)	Color (Signal)
1	Blue (B-)
2	Red (B+)
3	Green (A-)
4	Black (A+)

• Encoder Extension Cable between SS-EC drive and AM11SS Motor

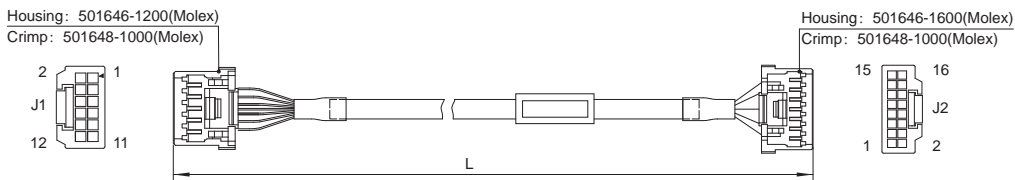

P/N	Length (L)
2118-100	1M
2118-300	3M
2118-500	5M
2118-1000	10M

Wiring Diagram						
PIN (J1)	Color (Signal)	PIN (J2)	PIN (J1)	Color (Signal)	PIN (J2)	
10	Blue (A+)	1		Brown (U+)		
9	Blue/Black (A-)	2		Brown/Black (U-)		
8	Green (B+)	3		Gray (V+)		
7	Green/Black (B-)	4		Gray/Black (V-)		
6	Yellow (Z+)	5	1	White (W+)	15	
5	Yellow/Black (Z-)	6	2	White/Black (W-)	16	
3	Red (+5V)	7	12	Shield	10	
4	Black (GND)	8				

• Encoder Extension Cable between SS-EC drive and AM17/23/24/34SS-N Motor

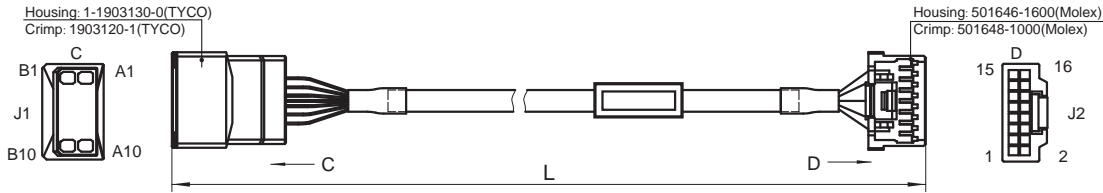

P/N	Length (L)
2117-100	1M
2117-300	3M
2117-500	5M
2117-1000	10M

Wiring Diagram					
PIN (J1)	Color (Signal)	PIN (J2)	PIN (J1)	Color (Signal)	PIN (J2)
A9	Blue (A+)	1	B5	Shield	10
B9	Blue/Black (A-)	2	A4	Brown (U+)	11
A8	Green (B+)	3	B4	Brown/Black (U-)	12
B8	Green/Black (B-)	4	A3	Gray (V+)	13
A7	Yellow (Z+)	5	B3	Gray/Black (V-)	14
B7	Yellow/Black (Z-)	6	A2	White (W+)	15
A6	Red (+5V)	7	B2	White (W+)	16
B6	Black (GND)	8			

• USB Cable

P/N	Length (L)
2620-150	1.5M

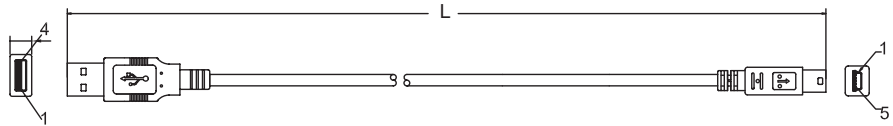

• Network Cable

Common Type	Shielded Type	Length (L)
2012-030 *	2013-030	0.3M
2012-300	2013-300	3M

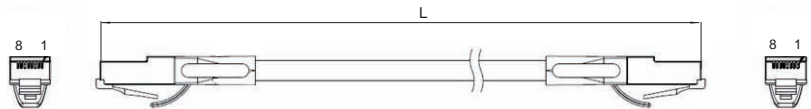

\* 2012-030 is included in the drive package.

# Contacting MOONS'

## MOONS' Headquarters

No. 168 Mingjia Road Industrial Park North  
Minhang District Shanghai 201107, P.R. China  
Tel: +86 (0)21 52634688  
Fax: +86 (0)21 52634098  
Email: info@moons.com.cn

## MOONS' International Trading Company

4/F, Building 30, 69 Guiqing Road, Cao He Jin Hi-Tech Park  
Shanghai 200233, P.R. China  
Tel: +86 (0)21 64952755  
Fax: +86 (0)21 64951993

## Domestic Offices

Shenzhen  
Room 2209, 22/F, Kerry Center, No. 2008 Renminnan Road  
Shenzhen 518001 P.R. China  
Tel: +86 (0)755 25472080  
Fax: +86 (0)755 25472081

Beijing  
Room 816, Block B, China Electronics Plaza,  
No. 3 Danling Street Haidian District Beijing 100080 P.R. China  
Tel: +86 (0)10 58753312  
Fax: +86 (0)10 58752279

Nanjing  
Room 302, Building A, Tengfei Creation Center,  
55 Jiangjun Ave, Jiangning District, Nanjing 211100 P.R. China  
Tel: +86 (0)25 52785841  
Fax: +86 (0)25 52785485

Qingdao  
Room 1012, Zhuoyue Tower, No. 16 Fengcheng Road,  
Shibei District, Qingdao 266000 P.R. China  
Tel: +86 (0)532 80969935  
Fax: +86 (0)532 80919938

Wuhan  
Room 3001, World Trade Tower, No. 686 Jiefang Ave  
Jiangnan District, Wuhan 430022 P.R. China  
Tel: +86 (0)27 85448742  
Fax: +86 (0)27 85448355

Chengdu  
Room 1917, Western Tower  
No. 19, 4th Section of South People Road, Wuhou District,  
Chengdu 610041 P.R. China  
Tel: +86 (0)28 85268102  
Fax: +86 (0)28 85268103

Xi'an  
Room 1006, Block D, Wangzuo International City  
No. 1 Tangyan Road, Xi'an 710065 P.R. China  
Tel: +86 (0)29 81870400  
Fax: +86 (0)29 818703

Ningbo  
Room 309, Tower B, Taifu Plaza, 565 Jiangjia Road  
Jiangdong District, Ningbo, 315040 P.R. China  
Tel: +86 (0)574 87052739  
Fax: +86 (0)574 87052365

Guangzhou  
Room 4006, Tower B, China Shine Plaza, 9 Linhe Xi Road  
Tianhe District, Guangzhou, 510610 P.R. China  
Tel: +86 (0)20 38010153  
Fax: +86 (0)20 38103661

## North America

MOONS' Industries (America), Inc.  
1113 North Prospect Avenue, Itasca, IL 60143 USA  
Tel: +1 630 833 5940  
Fax: +1 630 833 5946

APPLIED MOTION PRODUCTS, INC.  
404 Westridge Drive, Watsonville, CA 95076, USA  
Tel: +1 831 7616555  
Fax: +1 831 7616544

LIN ENGINEERING, INC.  
16245 Vineyard Blvd., Morgan Hill, CA 95037 USA  
Tel: +1 408 9190200  
Fax: +1 408 9190201

## Europe

MOONS' Industries Europe S.R.L.  
Via Torri Bianche n.1 20059 Vimercate (MB) Italy  
Tel: +39 039 62 60 521  
Fax: +39 039 96 31 409

## South-East Asia

MOONS' Industries (South-East Asia) PTE LTD.  
33 Ubi Avenue 3 #08-23 Vertex Singapore 408868  
Tel: +65 6634 1198  
Fax: +65 6634 1138

## Japan

MOONS' INDUSTRIES JAPAN CO., LTD.  
Room 601, 6F, Shin Yokohama Koushin Building  
2-12-1, Shin-Yokohama, Kohoku-ku, Yokohama  
Kanagawa, 222-0033, Japan  
Tel: +81 (0)45-4755788  
Fax: +81 (0)45 4755787



<http://www.moonsindustries.com>  
E-mail: ama-info@moons.com.cn  
**MOONS'**  
*moving in better ways*

