

RS03/06-S/Q

Step-Servo System Hardware Manual

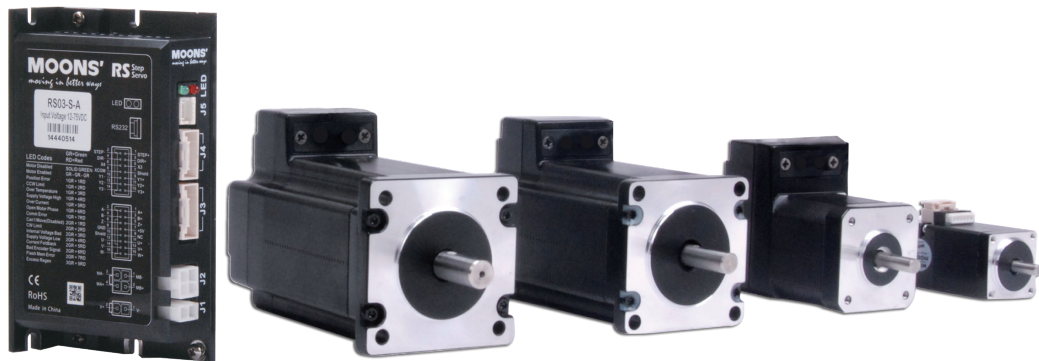

SHANGHAI AMP & MOONS' AUTOMATION CO.,LTD.

Contents

1. Introduction.....	4
1.1 Features.....	4
1.2 Block Diagram	5
1.3 Safety Instructions	6
2. Getting Started	7
2.1 Installing Software	7
2.2 Mounting the Hardware	9
2.3 Choosing a Power Supply	10
2.3.1 Voltage	10
2.3.2 Regeneration Clamp	10
2.3.3 Current.....	11
3. Installation/Connections	19
3.1 Connecting the Power Supply	19
3.2 Connecting the Motor	20
3.3 Connecting to the PC using RS-232.....	21
3.4 Inputs and Outputs	22
3.4.1 Digital Inputs.....	23
3.4.1.1 X1/STEP/CW Limit and X2/DIR/CCW Limit High Speed Digital Inputs.....	23
3.4.1.2 X3/EN, X4/AR Digital Inputs	25
3.4.2 Digital Outputs.....	26
3.4.2.1 Y1/ALARM, Y2/IN POSITION, Y3/BRAKE Digital Outputs	26
4. Troubleshooting	27
4.1 LED Error Codes	27
5. Reference Materials	28
5.1 Drive Mechanical Outlines (Unit: mm)	28
5.2 Technical Specifications.....	29
5.3 Recommended Motor	30
5.4 Motor Outlines	31
AM11RS	31
AM17RS	31
AM23RS	32
AM24RS	33
5.5 Torque Curves	34
AM11RS Series	34

AM17RS Series34
 AM23RS Series35
 AM24RS Series35
 5.6 Motor Numbering System36
 5.7 Drive Numbering System36
 6. Optional Accessories (Sold separately).....37
 7. Contacting MOONS'41

This User Manual is only applicable to the following models.

Models	Communication
	RS-232
RS03-S-A	✓
RS06-S-A	✓
RS03-Q-A	✓
RS06-Q-A	✓

1. Introduction

Thank you for selecting the MOONS' RS series Step-Servo drive and motor. The Step-Servo is an innovative revolution for the world of stepper motor; it enhances the stepper motors with servo technology to create a product with exceptional feature and broad capability.

1.1 Features

- Programmable, digital step-servo drive and motor package
- Operates from a 24 to 70 volt DC power supply
- Control modes:
 - Torque Control
 - * SCL command
 - Velocity Control
 - * Digital input Control Velocity
 - * SCL command Velocity
 - Position Control
 - * Digital Input
 - Pulse & Direction
 - CW/CCW Pulse
 - A/B quadrature(Encoder following)
 - * SCL command
 - Q programming(-Q model only)
 - * Stand alone operation
- RS-232 serial communication
- Encoder resolution: 1024 lines (4096 counts/rev) for RS step-servo motor
- RS03 output current: continuous 3A, boost 4A
- RS06 output current: continuous 6A, boost 7.5A
- 4 optically isolated digital inputs, with adjustable bandwidth digital noise rejection filter, 5-24VDC
- 3 optically isolated digital outputs, max 30V/100mA
- Technological advance
 - Full servo control, Closed loop
 - Efficient, Accurate, Fast, Smooth
 - Intelligent, Compact

1.2 Block Diagram

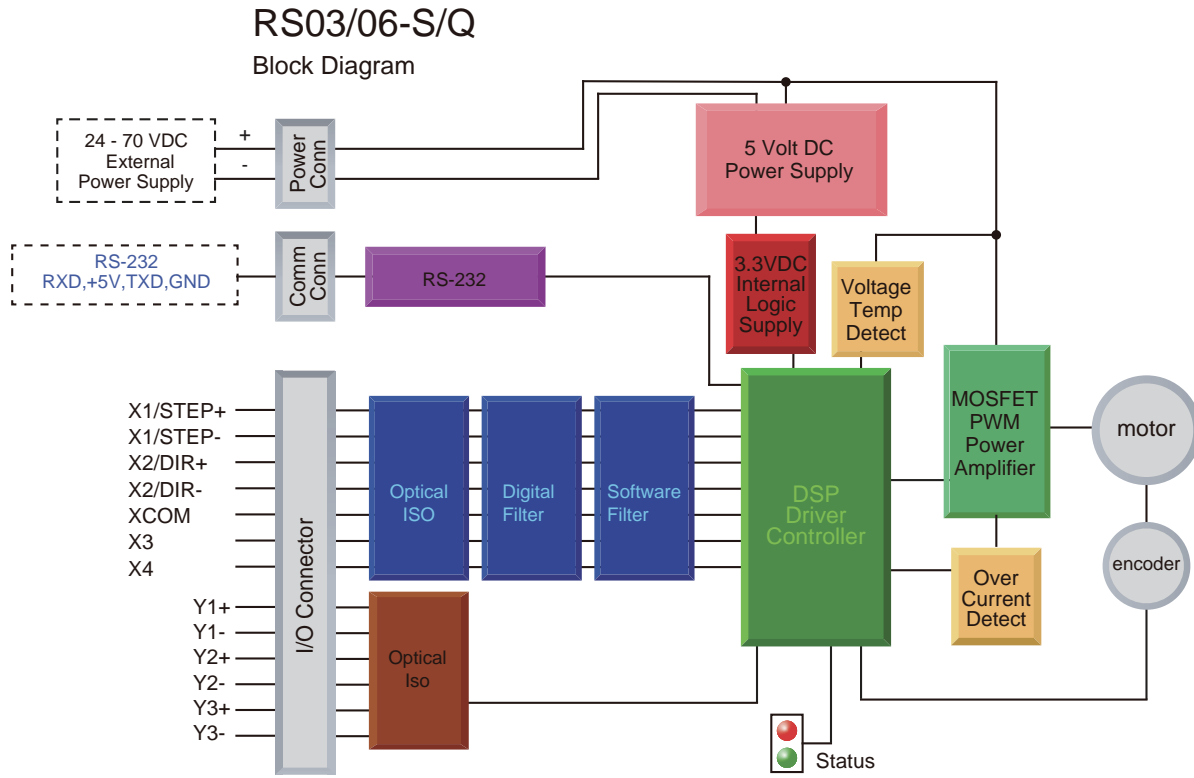

1.3 Safety Instructions

Only qualified personnel should transport, assemble, install, operate, or maintain this equipment. Properly qualified personnel are persons who are familiar with the transport, assembly, installation, operation, and maintenance of motors, and who meet the appropriate qualifications for their jobs.

To minimize the risk of potential safety problems, all applicable local and national codes regulating the installation and operation of equipment should be followed. These codes may vary from area to area and it is the responsibility of the operating personnel to determine which codes should be followed, and to verify that the equipment, installation, and operation are in compliance with the latest revision of these codes.

Equipment damage or serious injury to personnel can result from the failure to follow all applicable codes and standards. MOONS' does not guarantee the products described in this publication are suitable for a particular application, nor do they assume any responsibility for product design, installation, or operation.

- Read all available documentation before assembly and operation. Incorrect handling of the products referenced in this manual can result in injury and damage to persons and machinery. All technical information concerning the installation requirements must be strictly adhered to.
- It is vital to ensure that all system components are connected to earth ground. Electrical safety is impossible without a low-resistance earth connection.
- This product contains electrostatically sensitive components that can be damaged by incorrect handling. Follow qualified anti-static procedures before touching the product.
- During operation keep all covers and cabinet doors shut to avoid any hazards that could possibly cause severe damage to the product or personal health.
- During operation, the product may have components that are live or have hot surfaces.
- Never plug in or unplug the Integrated Motor while the system is live. The possibility of electric arcing can cause damage.

Be alert to the potential for personal injury. Follow recommended precautions and safe operating practices emphasized with alert symbols. Safety notices in this manual provide important information. Read and be familiar with these instructions before attempting installation, operation, or maintenance. The purpose of this section is to alert users to the possible safety hazards associated with this equipment and the precautions necessary to reduce the risk of personal injury and damage to equipment. Failure to observe these precautions could result in serious bodily injury, damage to the equipment, or operational difficulty.

2. Getting Started

The following items are needed:

- A 24-70 Volt DC power supply, see the section below entitled “Choose a Power Supply” for help in choosing the right one.
- A compatible RS motor, please see the section below entitled “Recommended Motor”
- A small flat blade screwdriver for tightening the connectors screw (included)
- A PC running Microsoft Windows XP/Vista/Windows 7/Windows 8 32-bit or 64-bit (Using serial communication port. Need a USB to Serial converter if the PC doesn't have)
- A RS-232 communication cable (included)

2.1 Installing Software

Step-Servo Quick Tuner is the PC based software application used to configure, and perform servo tuning, drive testing and evaluation of the step-servo products. System servo control gains, drive functionality and I/O configuration are set with Step-Servo Quick Tuner. It also contains an oscilloscope function to help set the servo control gains. For Q type driver, this software can be used to edit and download Q program to your drive. Motion simulation and status monitor are also included.

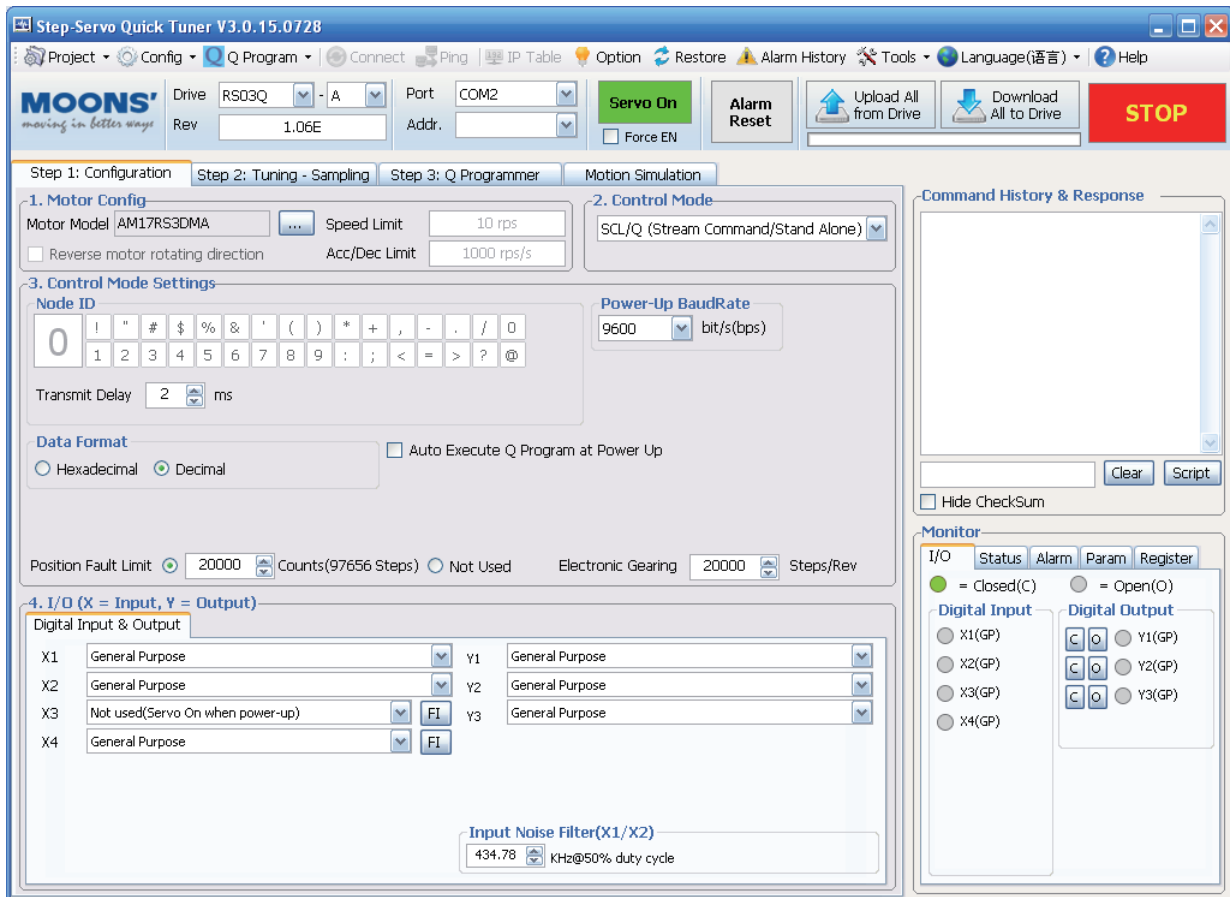

- Download the Step-Servo Quick Tuner from the MOONS' website and install it.
- Launch the software by clicking Start----Programs ----MOONS' -----Step-Servo Quick Tuner
- Connect the drive to PC by RS-232 cable. Please select right COM port in the software.
- Connect the drive to the Power Supply.
- Connect the motor to the drive.
- Power up the drive.
- The software will recognize your drive, display the model and firmware version and it's ready for action.

The connectors and other points of interest are illustrated below:

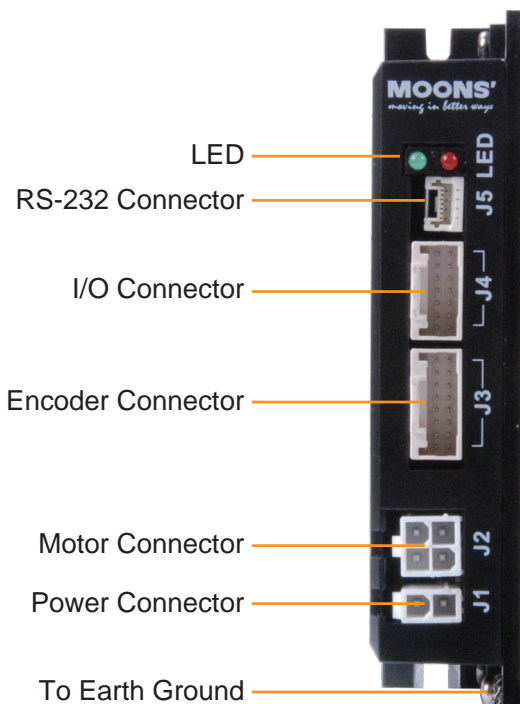

Model	
RS03-S-A	RS06-S-A
RS03-Q-A	RS06-Q-A

2.2 Mounting the Hardware

Use the M3 or M4 screw to mount the RS series drive .The drive should be securely fastened to a smooth ,flat metal surface the will help conduct heat away from the chassis. If this is not possible, forced airflow from a fan maybe required to prevent the drive from overheating.



- Never use the drive where there is no airflow or where other devices cause the surrounding air to be more than 40° C (104° F).
- Never put the drive where it can get wet.
- Never use the drive where metal or other electrically conductive particles can infiltrate the drive.
- Always provide airflow around the drive. When mounting multiple RS drives near each other, maintain at least 1.5cm of space between drives.

2.3 Choosing a Power Supply

The main considerations when choosing a power supply are the voltage and current requirements for the application.

2.3.1 Voltage

The RS driver is designed to give optimum performance between 24 and 70 Volts DC. Choosing the voltage depends on the performance needed and motor/drive heating that is acceptable and/or does not cause a drive over-temperature. Higher voltages will give higher speed performance but will cause the RS driver to produce higher temperatures. Using power supplies with voltage outputs that are near the drive maximum may significantly reduce the operational duty-cycle.

The extended range of operation can be as low as 18 VDC minimum to as high as 75 VDC maximum. When operating below 18 VDC, the power supply input may require larger capacitance to prevent under-voltage and internal-supply alarms. Current spikes may make supply readings erratic. The supply input cannot go below 18 VDC for reliable operation. Absolute minimum power supply input is 18 VDC. If the Input supply drops below 18 VDC the low voltage alarm will be triggered. This will not fault the drive.

Absolute maximum power supply input is 75 VDC at which point an over-voltage alarm and fault will occur. When using a power supply that is regulated and is near the drive maximum voltage of 75 VDC, a voltage clamp may be required to prevent over-voltage when regeneration occurs. When using an unregulated power supply, make sure the no-load voltage of the supply does not exceed the drive's maximum input voltage of 75 VDC.

2.3.2 Regeneration Clamp

If a regulated power supply is being used, there may be a problem with regeneration. When a load decelerates rapidly from a high speed, some of the kinetic energy of the load is transferred back to the power supply, possibly tripping the over-voltage protection of a regulated power supply, causing it to shut down. This problem can be solved with the use of a MOONS' RC880 Regeneration Clamp. It is recommended that an RC880 initially be installed in an application. If the "regen" LED on the RC880 never flashes, the clamp is not necessary.

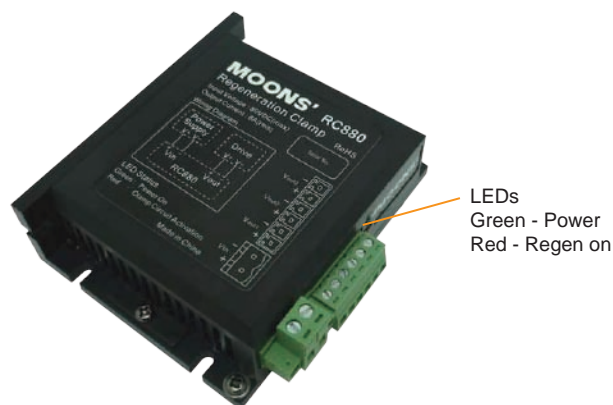

RC880 Regen Clamp

2.3.3 Current

The maximum supply currents required by the RS series step servo drive and motor are shown below in charts at different power supply voltage input. The RS drive power supply current is lower than the winding currents because it uses switching amplifiers to convert a high voltage and low current into low voltage and high current. The more power supply voltage exceeds the motor voltage, the less current will be required from the power supply.

It is important to note that the current draw is significantly different at higher speeds depending on the torque load to the motor. Estimating how much current is necessary may require a good analysis of the load to the motor.

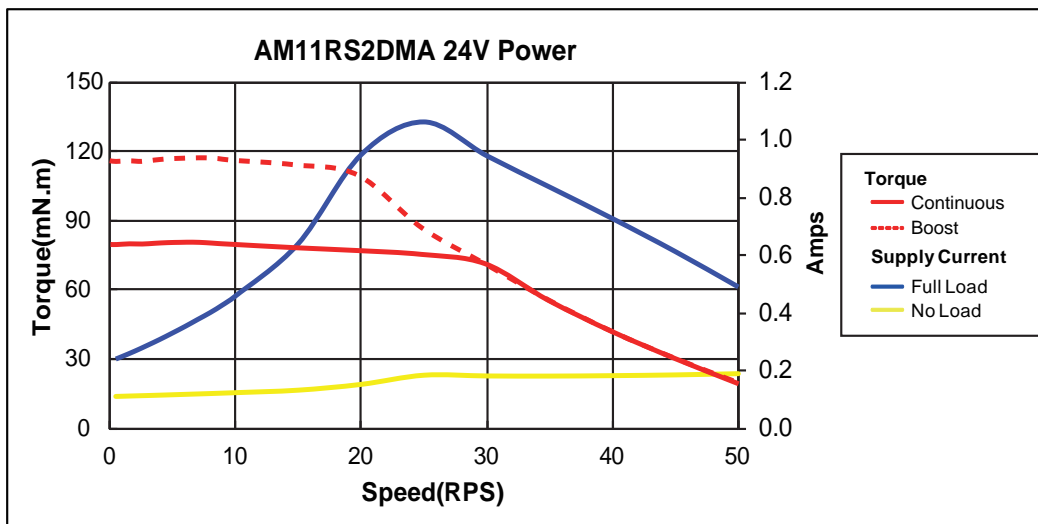
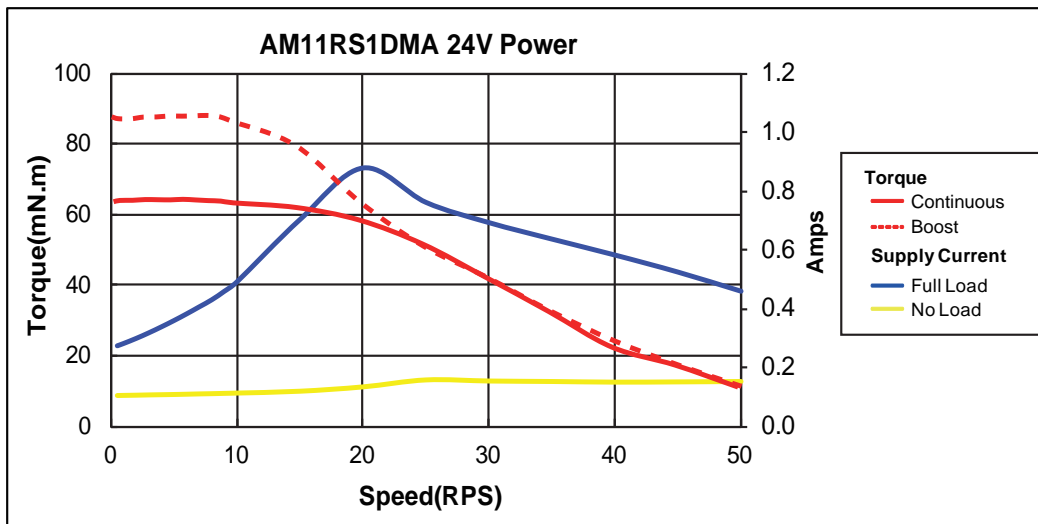

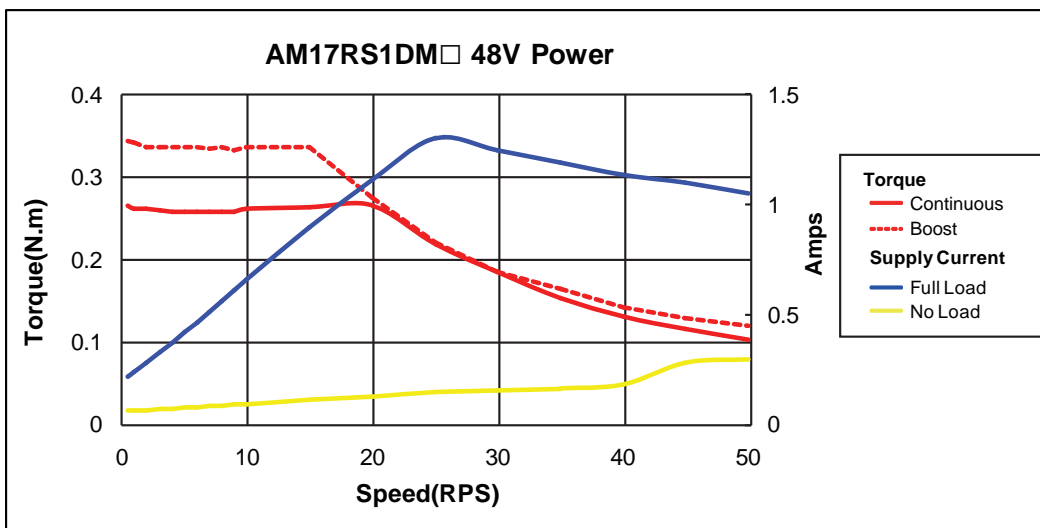
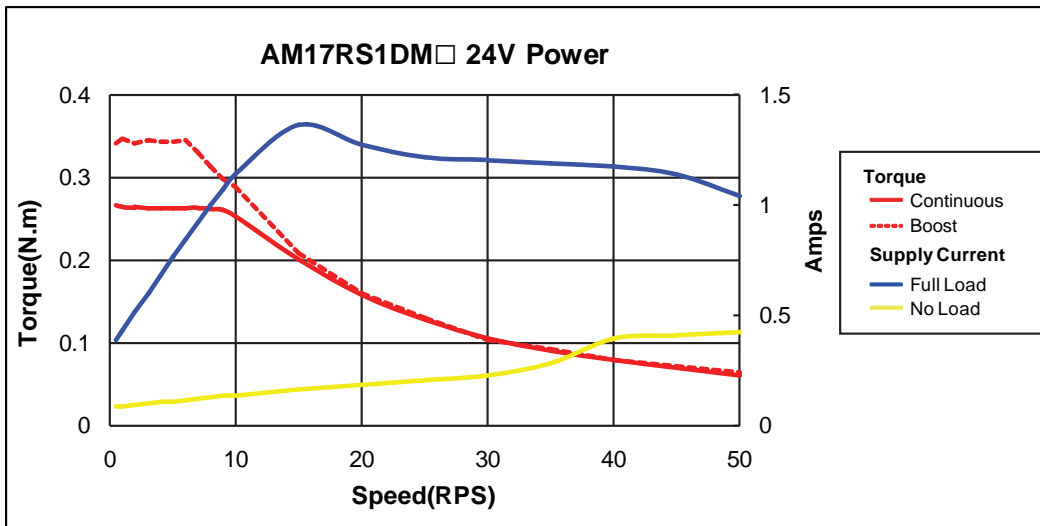
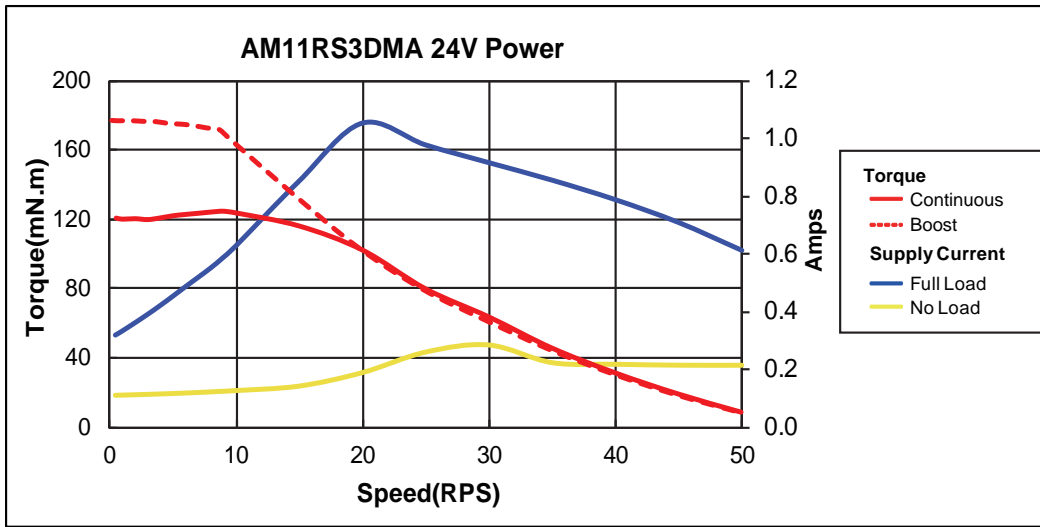

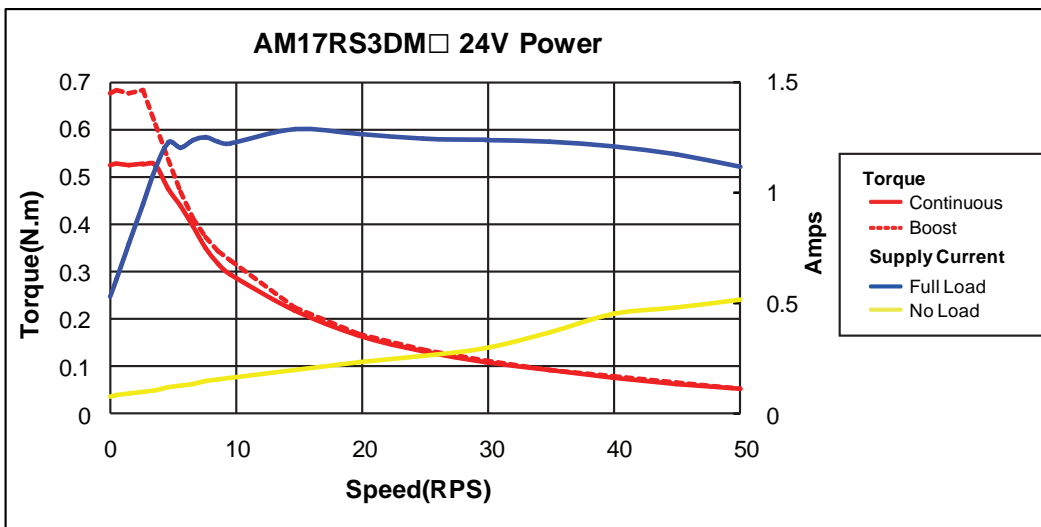
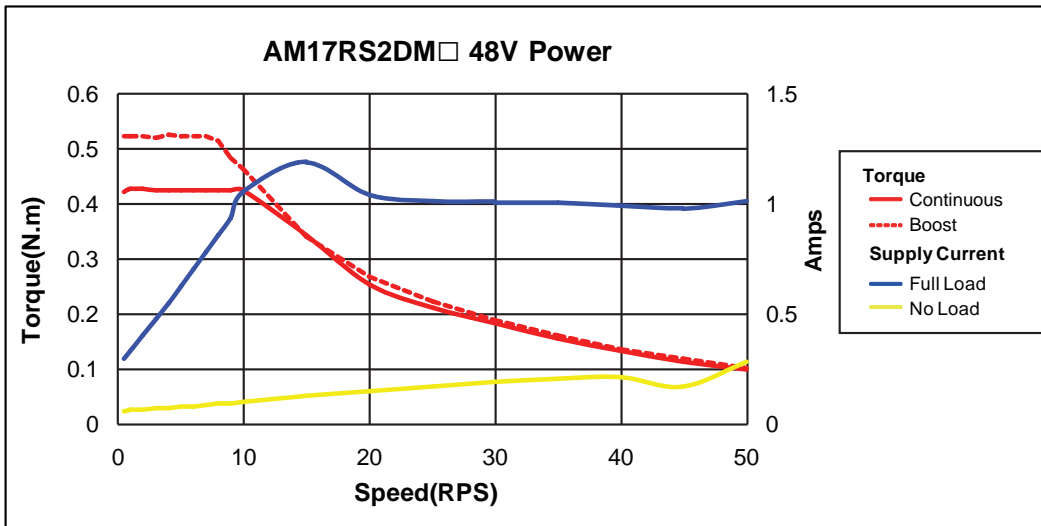
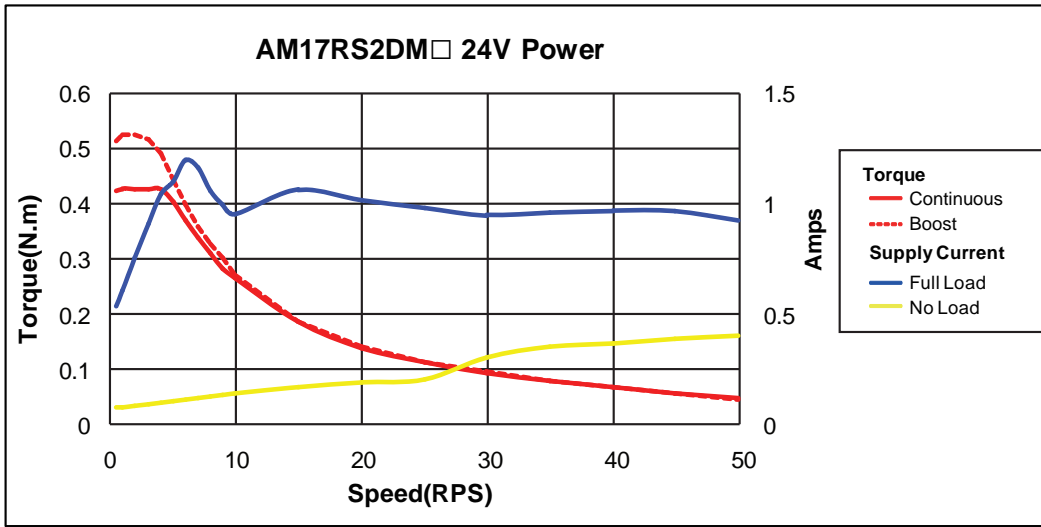

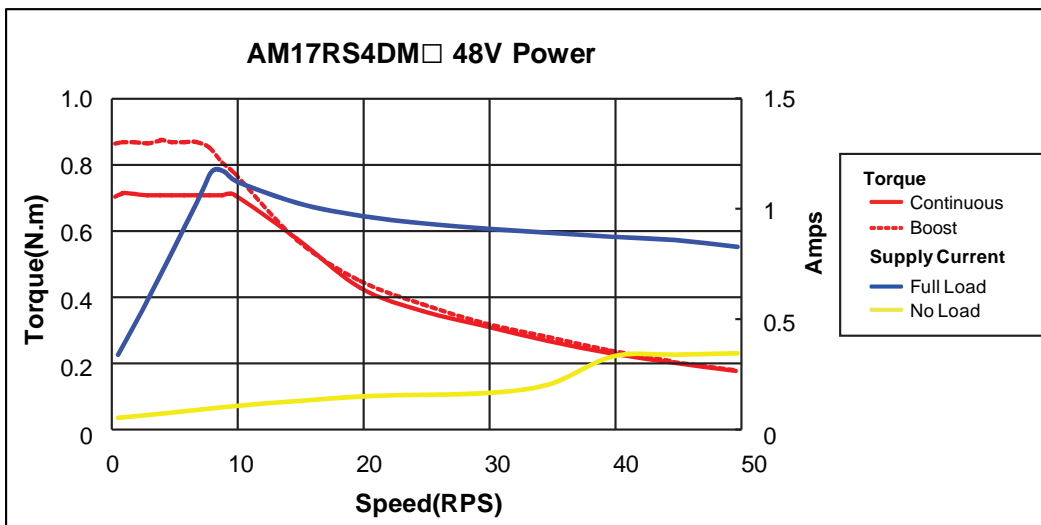
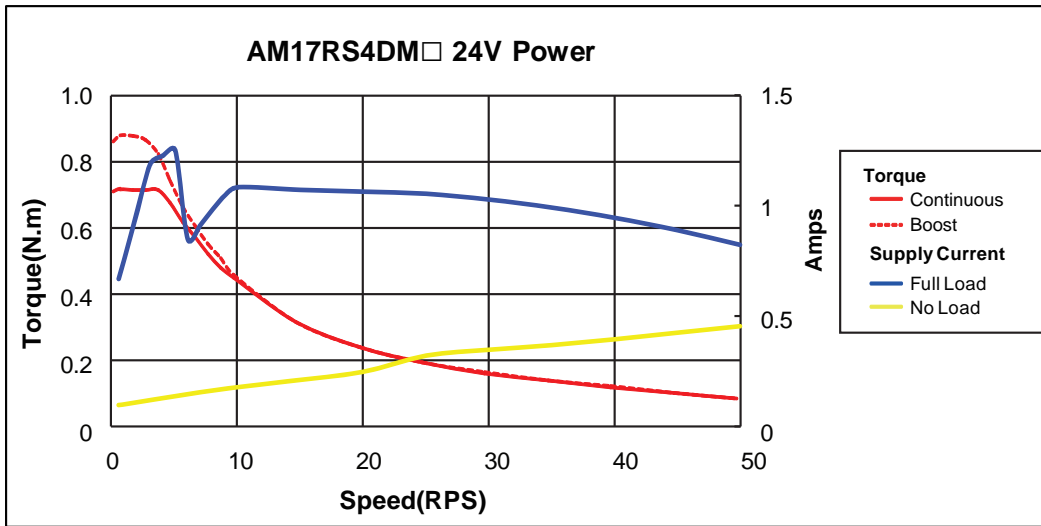
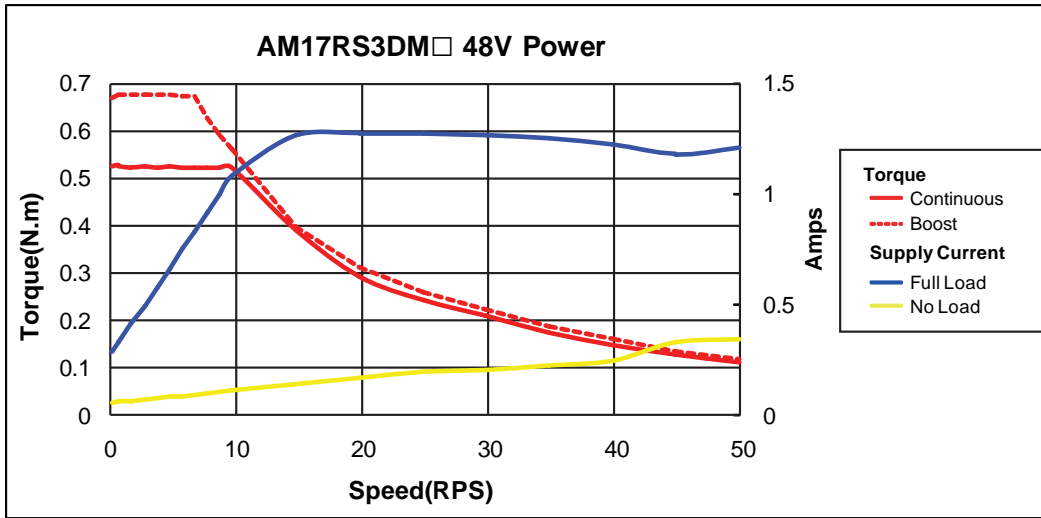

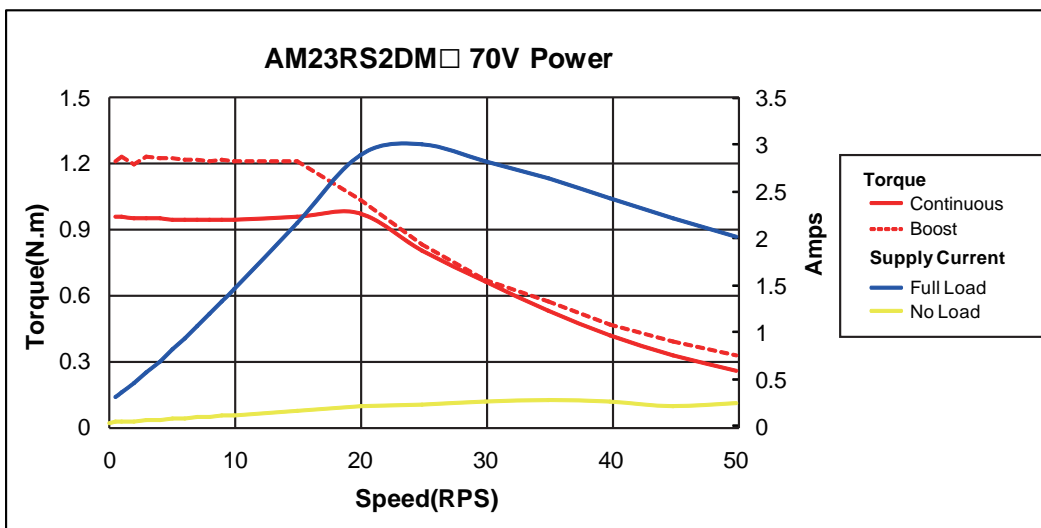
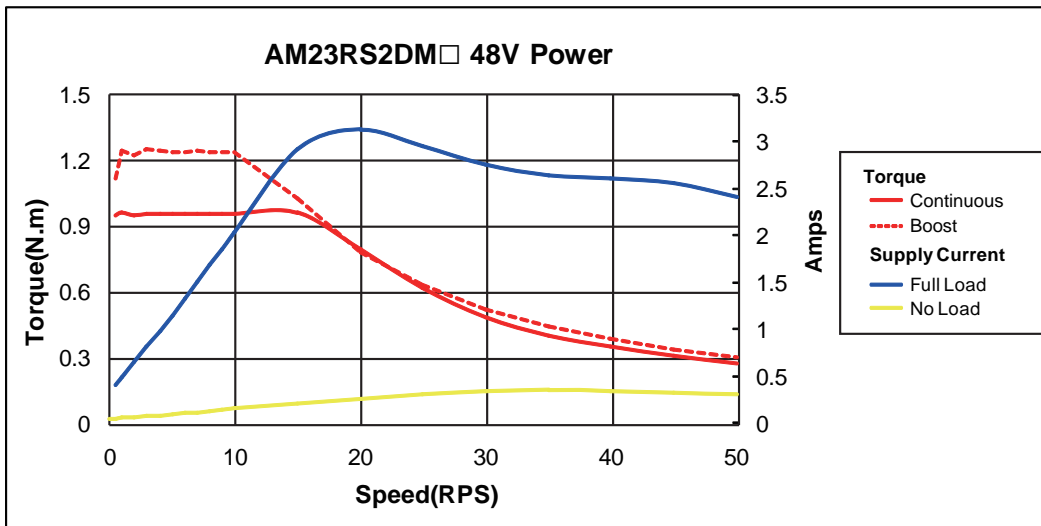
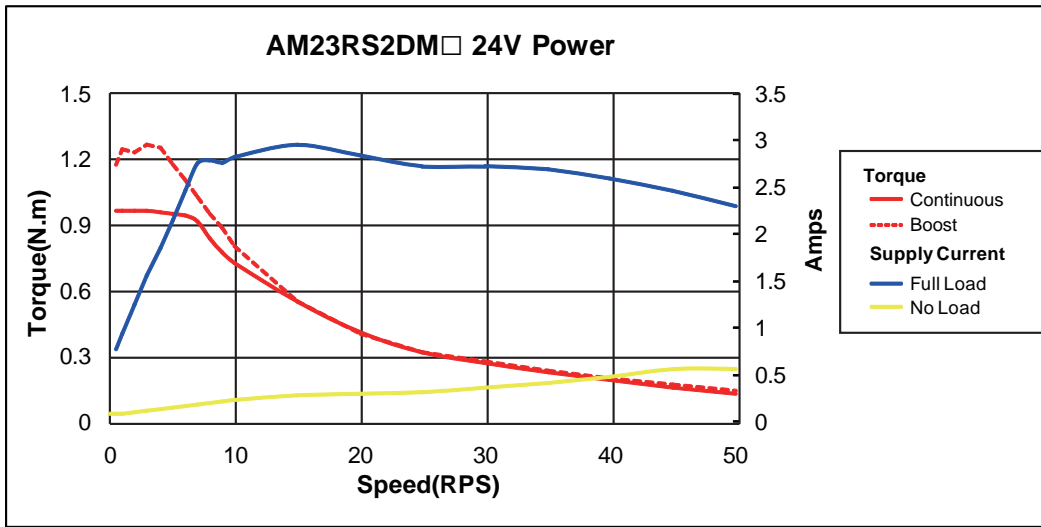

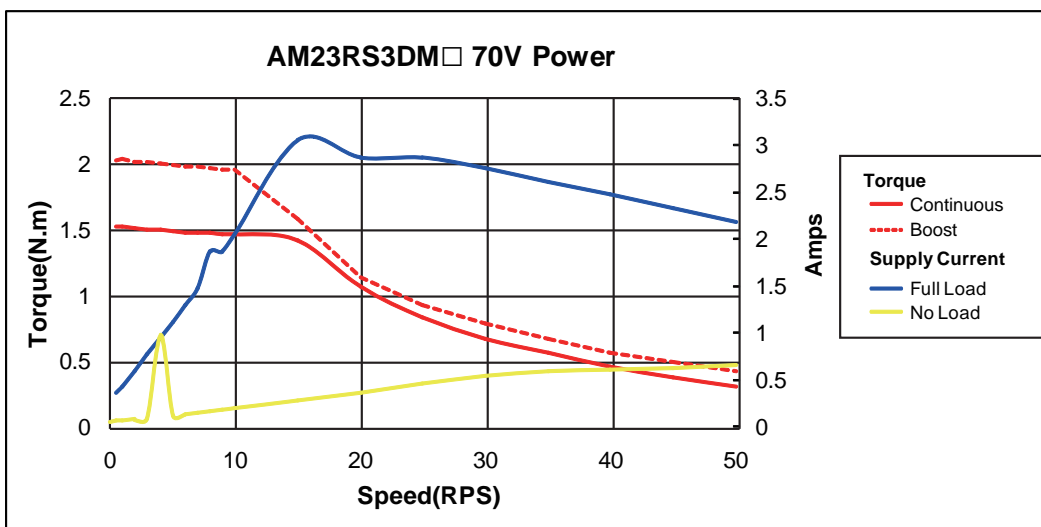
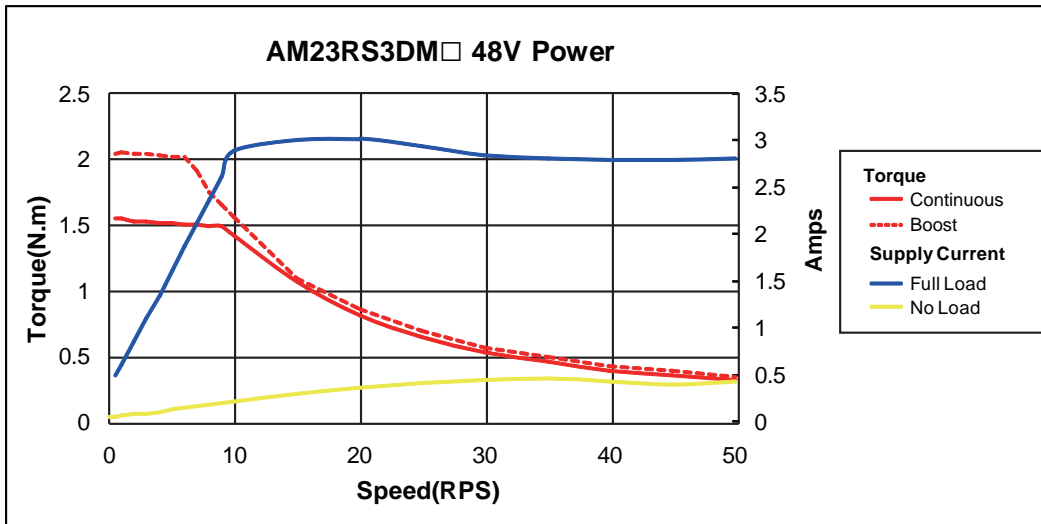
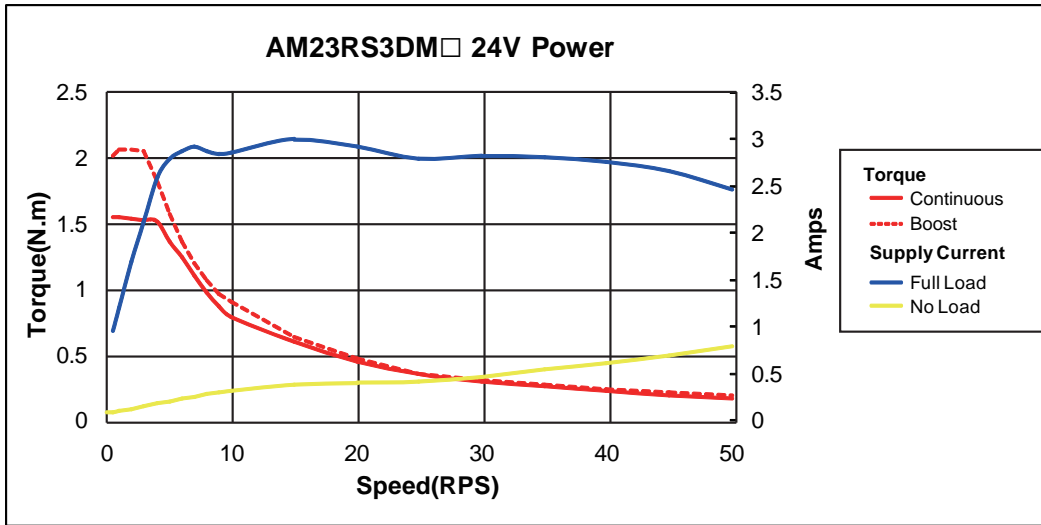

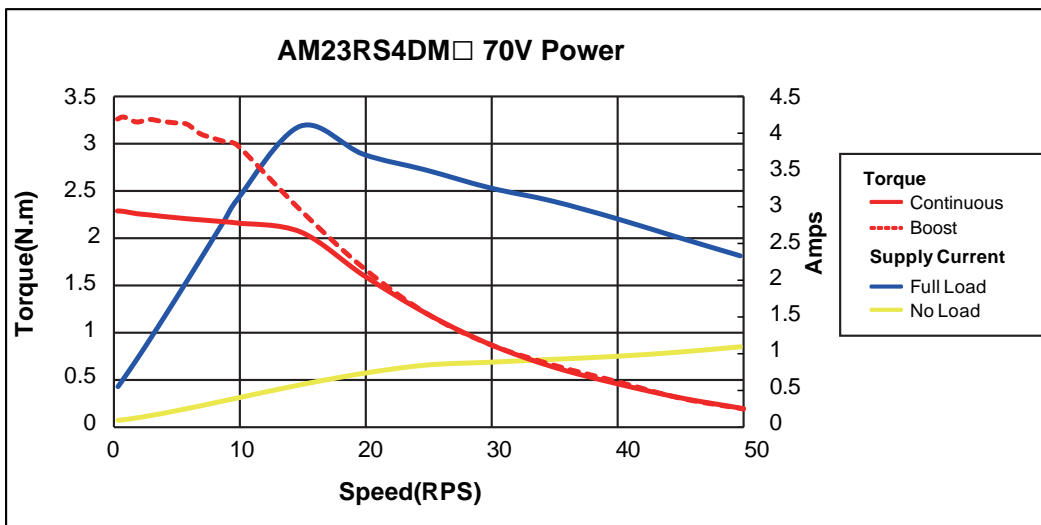
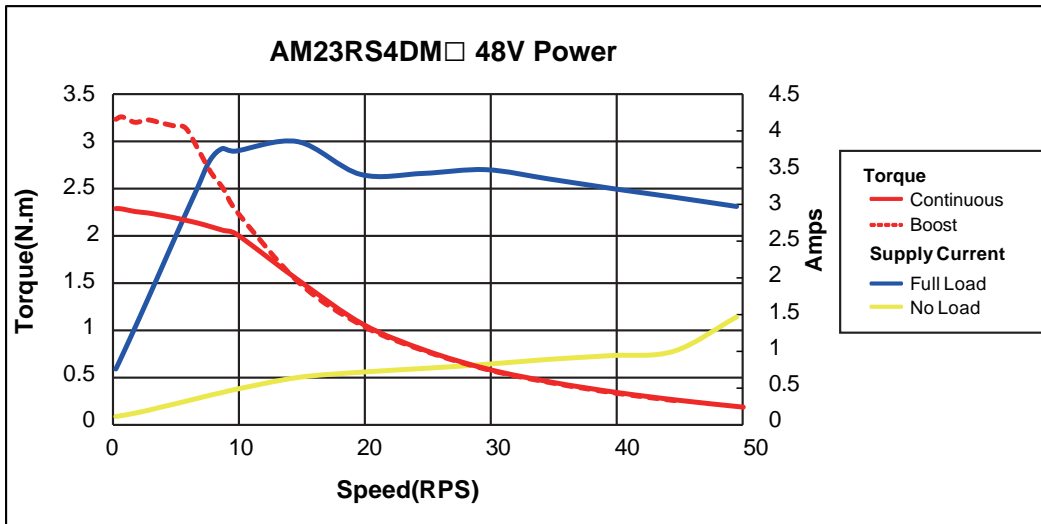
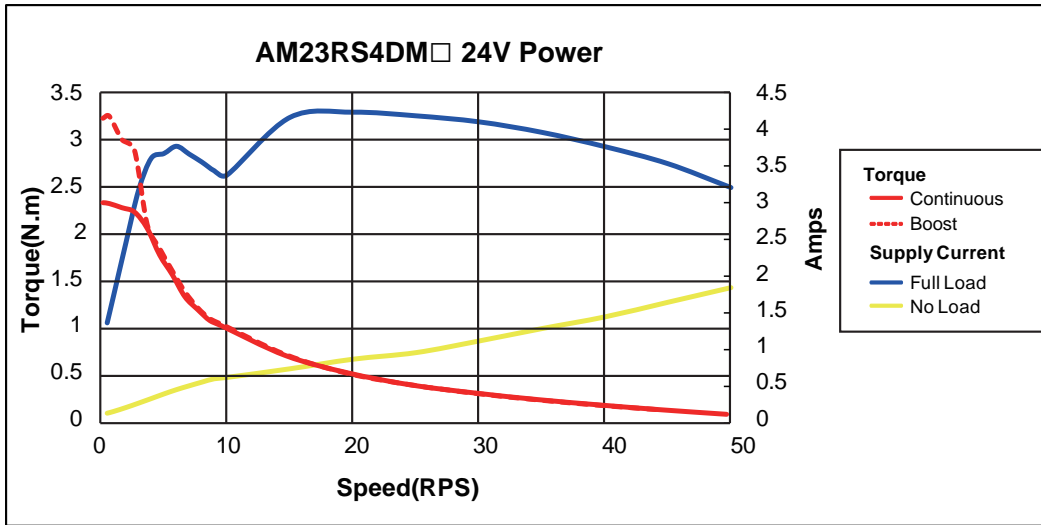

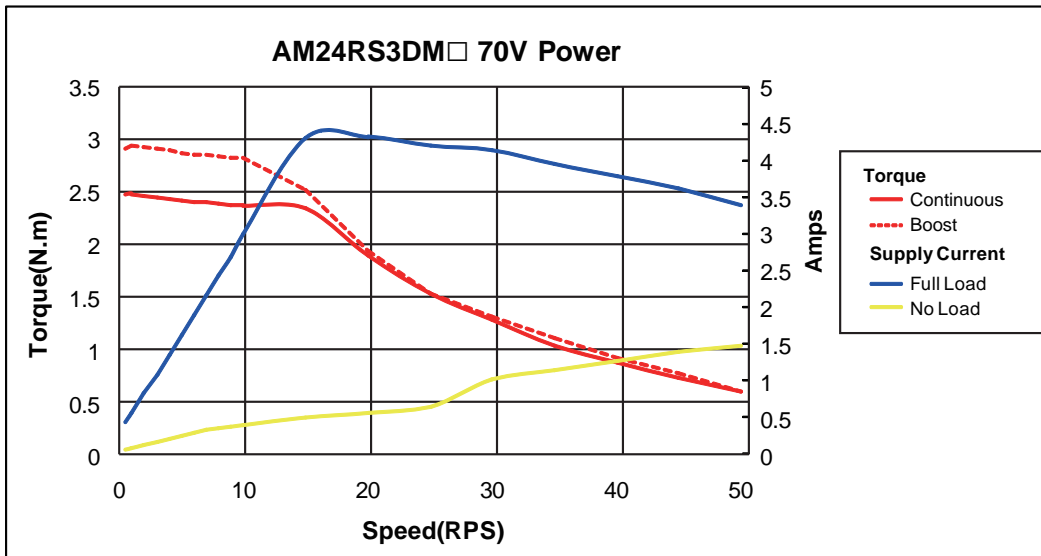
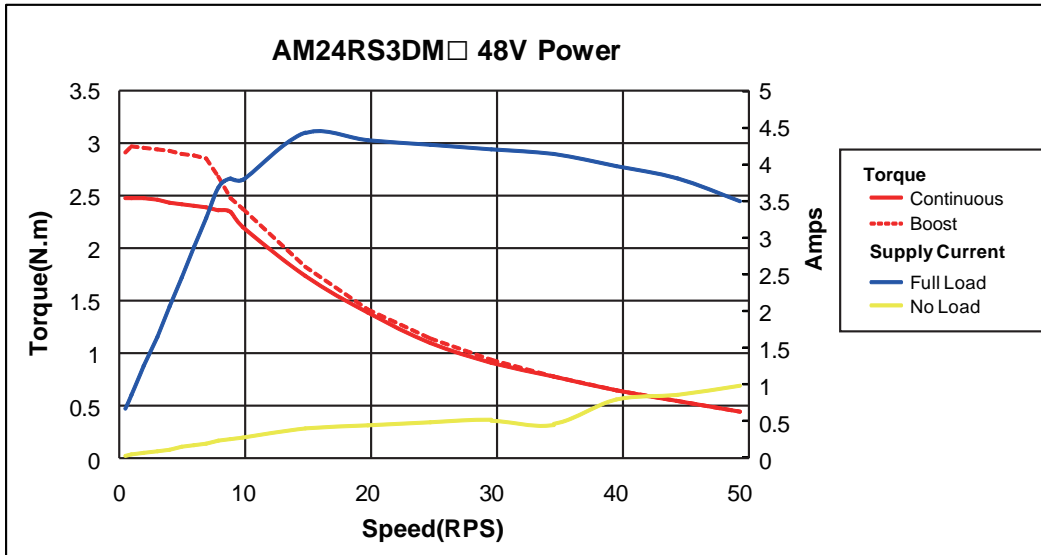
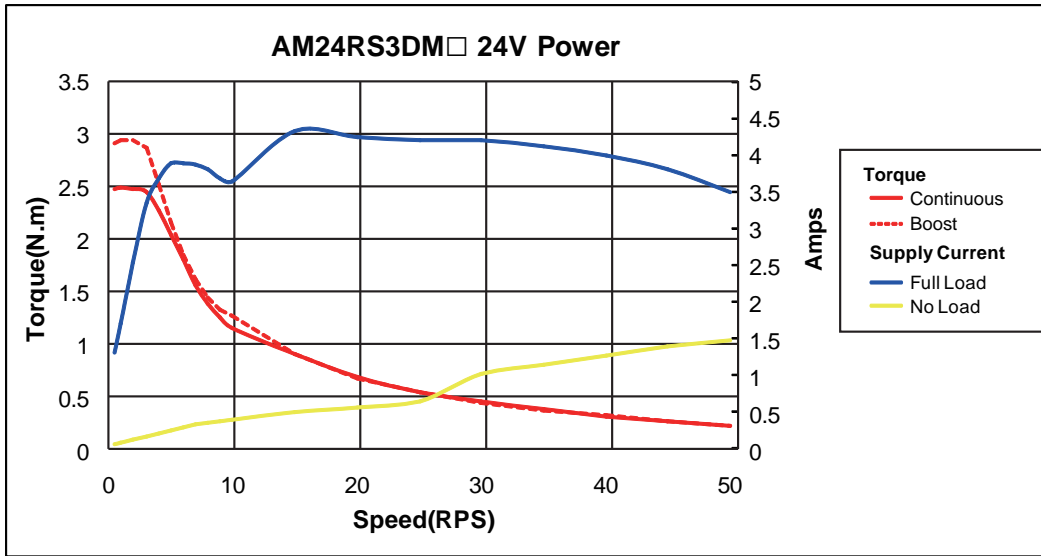

3. Installation/Connections

3.1 Connecting the Power Supply

The RS series step servo drive and motor are shipped with a power cable, 2 meters long. Connect the red wire to the positive of the power supply. Connect the black wire to the negative of the power supply. Plug the cable into the power connector of the drive.

The red wire is connected to the V+ of the drive. The black wire is connected to the V- of the drive.



Be careful not to reverse the wires. Reversing the connection may open the internal fuse on the drive and void the warranty.

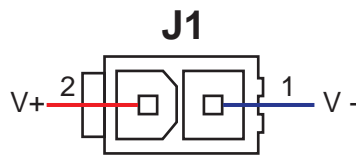

Power Connector

Connect the chassis to the earth ground through the grounding screws.



The section entitled “2.3 Choosing a Power Supply” will help you to select a right power supply.

3.2 Connecting the Motor

The RS motors have two cables. One is the motor power cable, the other one is the encoder feedback cable. Plug the motor power cable into the motor connector on the drive and plug the encoder feedback cable into the encoder feedback connector on the drive.

Do not damage or drag the cables on the motor.

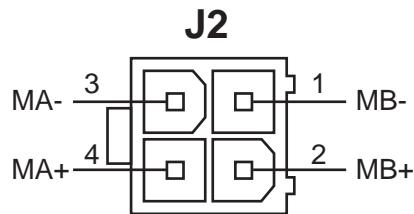

Motor connector on the driver

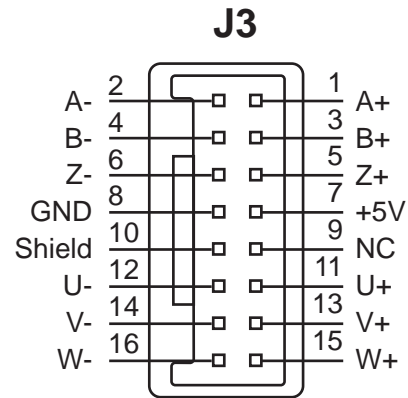

Encoder connector on the driver

3.3 Connecting to the PC using RS-232

The RS series step servo drive and motor are shipped with a 1.5 meters RS-232 communication cable. The DB9 connector is used to connect to PC. The small end is a crimping connector used to connect to the drive.

Located the RS series step servo drive and motor within 1.5 meters of the PC. Plug the DB9 connector into the serial COM port of the PC. Plug the small end crimping connector into the RS-232 port of the drive. Do not hot plug.

If the PC doesn't have a RS-232 serial port, a USB to RS232 converter will be needed. You can contact MOONS' to get a USB to RS-232 converter.

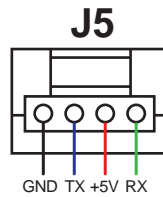

RS03/06-S/Q RS-232 Comm port
(View from the driver side)

Driver	Connection
GND	Connects to host GND
TX	Connects to host RX
+5V	Connects to host +5V
RX	Connects to host TX

3.4 Inputs and Outputs

RS03/06-S/Q inputs and outputs include:

- 4 optically isolated digital inputs, with adjustable bandwidth digital noise rejection filter, 5-24VDC
- 3 optically isolated digital outputs, max 30V/100mA

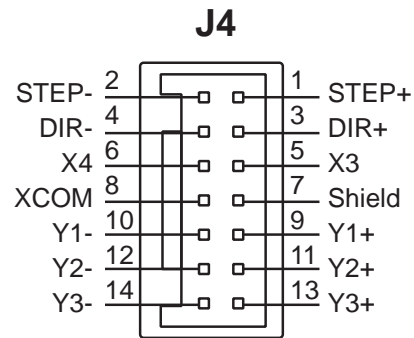

I/O Connector Diagram

3.4.1 Digital Inputs

3.4.1.1 X1/STEP/CW Limit and X2/DIR/CCW Limit High Speed Digital Inputs

X1/STEP and X2/DIR are high-speed digital inputs operation 5-24V optical isolated differential signal, minimum pulse width 250ns, maximum pulse frequency 2MHz.

- In Pulse and Direction mode, X1/STEP is pulse input and X2/DIR is direction signal input.
- In CW/CCW mode, X1/STEP is CW pulse input and X2/DIR is CCW pulse input.
- In A/B quadrature mode (Encoder following), X1/STEP is signal A input, X2/DIR is signal B input.
- In velocity mode, X1/STEP can be set to RUN/STOP, X2/DIR is direction signal. X1 and X2 also can be configured as CW JOG and CCW JOG.

The diagrams below show how to connect the X1/STEP and X2/DIR to various commonly used

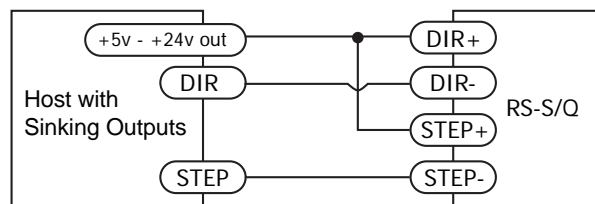

Connecting to Host with Sinking Outputs

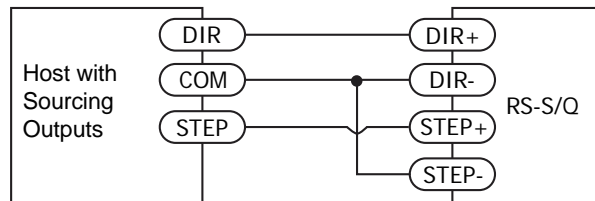

Connecting to Host with Sourcing Outputs

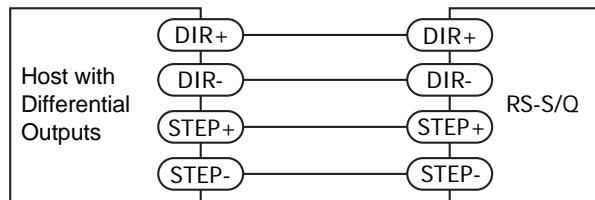

Connecting to Host with Differential outputs

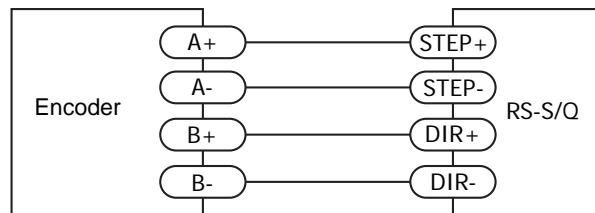

Connecting to An Encoder

- In SCL mode, X1 can be configured as CW limit sensor input and X2 can be configured as CCW limit sensor input.

NOTE:

If current is flowing into or out of an input , the logic state of that input is low or closed. If no current is flowing, or the input is not connected, the logic state is high or open.

The diagrams below show how to connect to CW LIMIT and CCW LIMIT. Please select the polarity of the limit sensor by using the Step-Servo Quick Tuner.

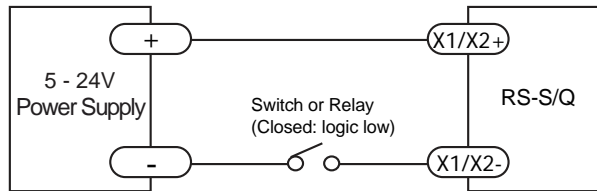

Connecting to a switch or relay

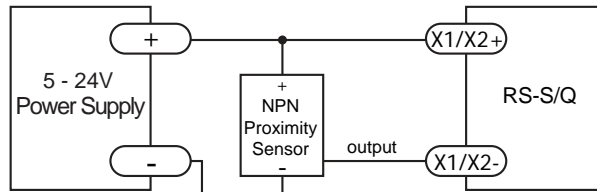

Connecting a NPN type Proximity Sensor to an Input
(when proximity sensor activates, output goes low)

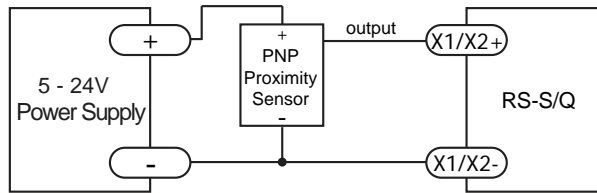

Connecting a PNP type Proximity Sensor to an input
(when proximity sensor activates, output goes high)

- In SCL mode, X1 and X2 can be configured as general purpose input for WI,OI,FS or SH and other commands.

3.4.1.2 X3/EN, X4/AR Digital Inputs

The X3/EN, X4/AR are digital inputs operation 5-24V optically isolated single-ended signal, sinking or sourcing, 5-24VDC, minimum pulse width 50 μ s, maximum pulse frequency 10KHz

X3 can be configured as enable signal input to servo on or off the motor and X4 can be configured as alarm reset signal input to clear the alarm and turns to the normal status as servo off.

In the velocity mode, X4 can also be configured as speed switch signal to change the speed to another one.

X3 and X4 can be configured as general purpose input for WI, OI, FS or SH and other commands.

Because the input is an optically isolated circuit, a 5-24V power supply is needed. For example, you can use the power supply of the PLC when you are using a PLC control system, but if you want to connect a relay or mechanical switch to the input, you must need a power supply.

XCOM is an electronics term for a single-ended signal connection to a common voltage. In the case of RS series, if you are using a sourcing(PNP) input signals, you need to connect XCOM to the ground(power supply -),if you are using a sinking(NPN) input signals ,the XCOM need to connect to the power supply +.

NOTE:

**If current is flowing into or out of an input, the logic state of that input is low or closed.
If no current is flowing ,or the input is not connected, the logic state is high or open.**

The charts below show how to connect to EN and AR. Please select the polarity of the inputs by using the Step-Servo Quick Tuner.

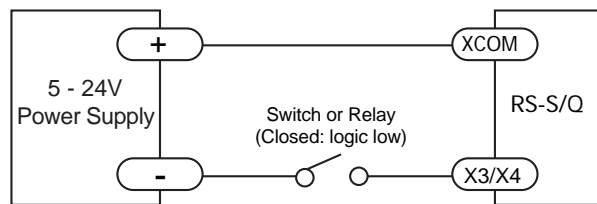

Connecting to a switch or relay

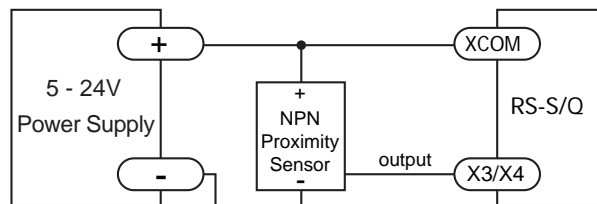

Connecting a NPN type Proximity Sensor to an Input (when proximity sensor activates, output goes low)

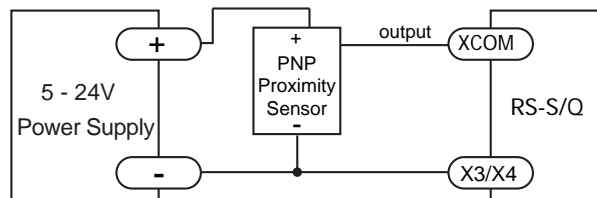

Connecting a PNP type Proximity Sensot to an input (when proximity sensor activates, output goes high)

3.4.2 Digital Outputs

3.4.2.1 Y1/ALARM, Y2/IN POSITION, Y3/BRAKE Digital Outputs

The Y1/Alarm, Y2/In-position, Y3/brake are optically isolated digital outputs, single-ended, sinking or sourcing, max. 30VDC/100mA.

- Y1 can be configured as alarm signal output.
- Y2 can be configured as dynamic in position signal output (dynamic, checking in position all the time.) It also can be configured as Tach signal output, tach output produce pulses relative to the motor position with configurable resolution. It can also be configured as Timing signal output, timing output produce 50 pulses relative to one turn of motor revolution.
- Y3 can be configured as signal output to release brake. It can also be configured as static in position signal output (static, checking in position when motor is stopped).

Y1, Y2 and Y3 can be configured by Step-Servo Quick Tuner as general purpose outputs.

The charts below show how to connect to the output:

NOTE:

**Do not connect the outputs to more than 30VDC power supply.
And the current of each output terminal must not exceed 100mA.**

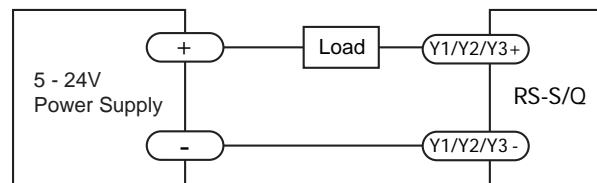

Connecting a Sinking Output

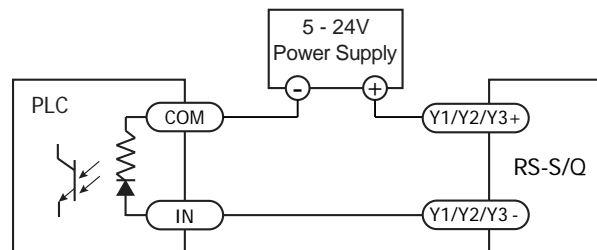

Connecting a Sourcing Output

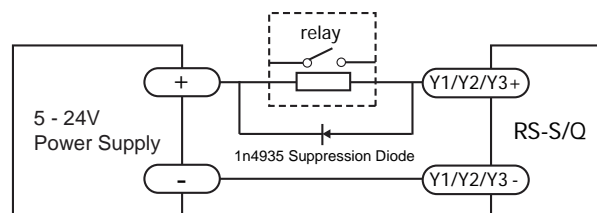



















Driving a Relay

4. Troubleshooting

4.1 LED Error Codes

The RS series step-servo package uses red and green LEDs to indicate status. When the motor is enabled, the green LED flashes slowly. When the green LED is solid, the motor is disabled. Errors are indicated by combinations of red and green flashes as shown below. This feature can be disabled for certain warnings but not for alarms. See software manual for information on how to do this and which warnings may be masked.

	Code	Error
	solid green	no alarm, motor disabled
	flashing green	no alarm, motor disabled
	1 red, 1 green	motor stall (optional encoder only)
	1 red, 2 green	can't move (Disabled)
	2 red, 1 green	ccw limit
	2 red, 2 green	cw limit
	3 red, 1 green	drive overheating
	3 red, 2 green	internal voltage out of range
	3 red, 3 green	blank Q segment
	4 red, 1 green	power supply overvoltage or excess regen
	4 red, 2 green	power supply undervoltage
	4 red, 3 green	flash memory backup error
	5 red, 1 green	Over current/short circuit
	5 red, 2 green	Current Foldback
	6 red, 1 green	Open motor winding
	6 red, 2 green	bad encoder signal (optional encoder only)
	7 red, 1 green	communication error
	7 red, 2 green	flash memory error

5. Reference Materials

5.1 Drive Mechanical Outlines (Unit: mm)

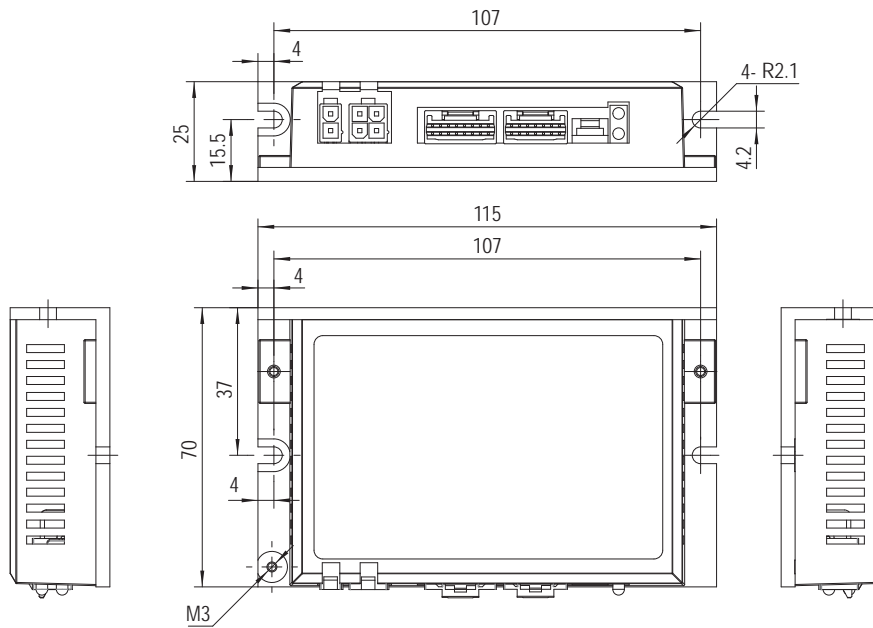

Model	
RS03-S-A	RS03-Q-A
RS06-S-A	RS06-Q-A

5.2 Technical Specifications

Power Amplifier	
Amplifier Type	Dual H-Bridge, 4 Quadrant
Current Control	4 state PWM at 20 KHz
Output Current	RS03: Continuous Current 3A max, Boost Current 4.0A max (1.5s), current limitation auto set-up by attached motor
	RS06: Continuous Current 6A max, Boost Current 7.5A max (1.5s), current limitation auto set-up by attached motor
Power Supply	External nominal 24 - 70 volt DC power supply required, Absolute maximum input voltage range 18 - 75 VDC
Protection	Over-voltage, under-voltage, over-temp, motor/winding shorts (phase-to-phase, phase-to-ground)
Controller	
Electronic Gearing	Software selectable from 200 to 51200 steps/rev in increments of 2 steps/rev
Filters	Digital input noise filter, Smoothing filter, PID filter, Notch filter
Non-Volatile Storage	Configurations are saved in FLASH memory on-board the DSP
Modes of Operation	S/Q type: Position Mode(Pulse & Direction, CW & CCW Pulse, A/B Quadrature); Torque Mode, Velocity Mode, SCL Mode
	Q type: Position Mode(Pulse & Direction, CW & CCW Pulse, A/B Quadrature); Torque Mode, Velocity Mode, SCL Mode, Q Programming
Digital Inputs	S/Q type: X1/STEP, X2/DIR: Optically isolated, differential, 5-24VDC; Minimum pulse width = 250 ns, Maximum pulse frequency = 2 MHz; X3, X4: optically isolated, single-ended, sinking or sourcing, 5-24VDC, minimum pulse width 50µs, maximum pulse frequency 10KHz
Digital Outputs	S/Q type: Y1/Alarm, Y2/In Position, Y3/Brake; Optically isolated, 30V/100 mA max
Communication	RS-232
Physical	
Ambient Temperature	0 to 40°C (32 to 104°F) when mounted to a suitable heatsink
Ambient Humidity	90% Max., non-condensing
Mass	Approx 0.2 Kg

5.3 Recommended Motor

Motor Part Number	Frame Size	Holding Torque (N.m)	Matching Drive
AM11RS1DMA	28	0.065N•m	RS03- ■ - A
AM11RS2DMA		0.08N•m	
AM11RS3DMA		0.125N•m	
AM17RS1DM□	42	0.3N•m	
AM17RS2DM□		0.5N•m	
AM17RS3DM□		0.6N•m	
AM17RS4DM□		0.75N•m	
AM23RS2DM□	56	0.9N•m	RS06- ■ - A
AM23RS3DM□		1.5N•m	
AM23RS4DMA		2.5N•m	
AM24RS3DM□	60	2.5N•m	

□: A or B, refer to motor part numbering system

■: S or Q, refer to driver part numbering system

5.4 Motor Outlines

AM11RS

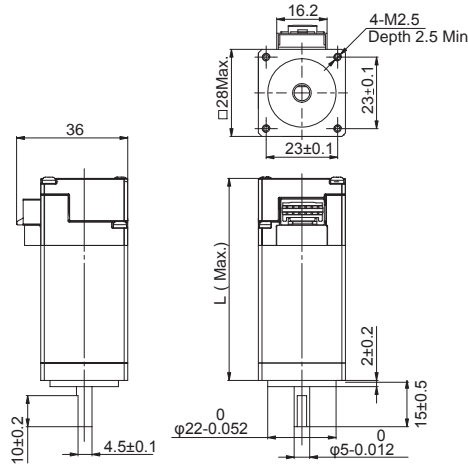

Type(Unit: mm)	
Model	L
AM11RS1DMA	43.8
AM11RS2DMA	52.9
AM11RS3DMA	64.1

AM17RS

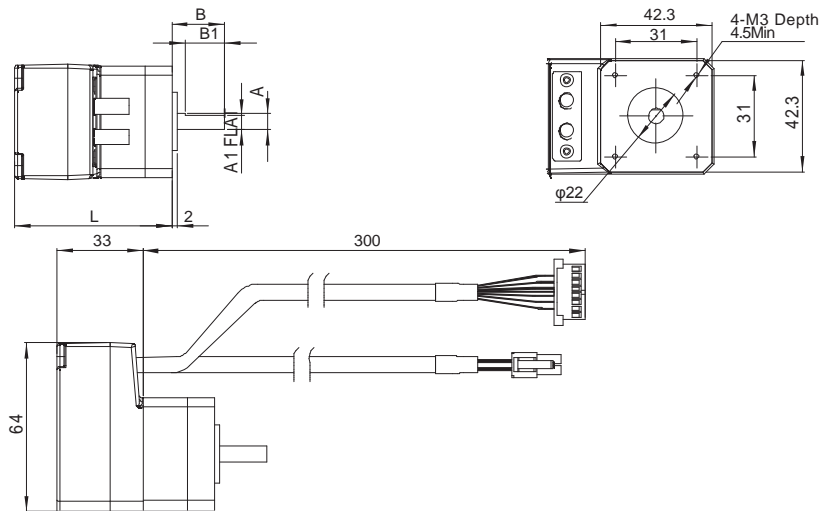

Type(Unit: mm)					
Model	A	A1	B	B1	L
AM17RS1DMA	φ 6	5.5	20	15	59.5
AM17RS1DMB	φ 5	4.5	24	15	59.5
AM17RS2DMA	φ 6	5.5	20	15	65
AM17RS2DMB	φ 5	4.5	24	15	65
AM17RS3DMA	φ 6	5.5	20	15	73.5
AM17RS3DMB	φ 5	4.5	24	15	73.5
AM17RS4DMA	φ 6	5.5	20	15	89
AM17RS4DMB	φ 5	4.5	24	15	89

AM23RS

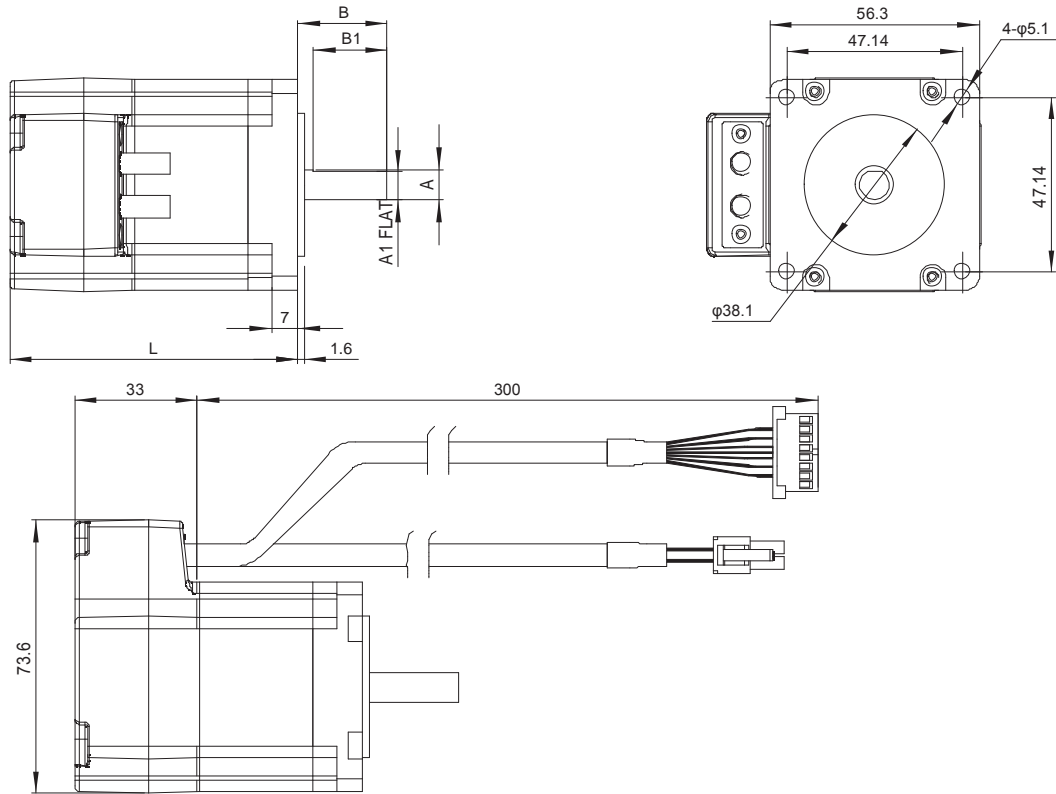

Type(Unit: mm)					
Model	A	A1	B	B1	L
AM23RS2DMA	φ 8	7.5	24	20	77.5
AM23RS2DMB	φ 6.35	5.85	20	15	77.5
AM23RS3DMA	φ 8	7.5	24	20	99.5
AM23RS3DMB	φ 6.35	5.85	20	15	99.5
AM23RS4DMA	φ 8	7.5	24	20	102.5

AM24RS

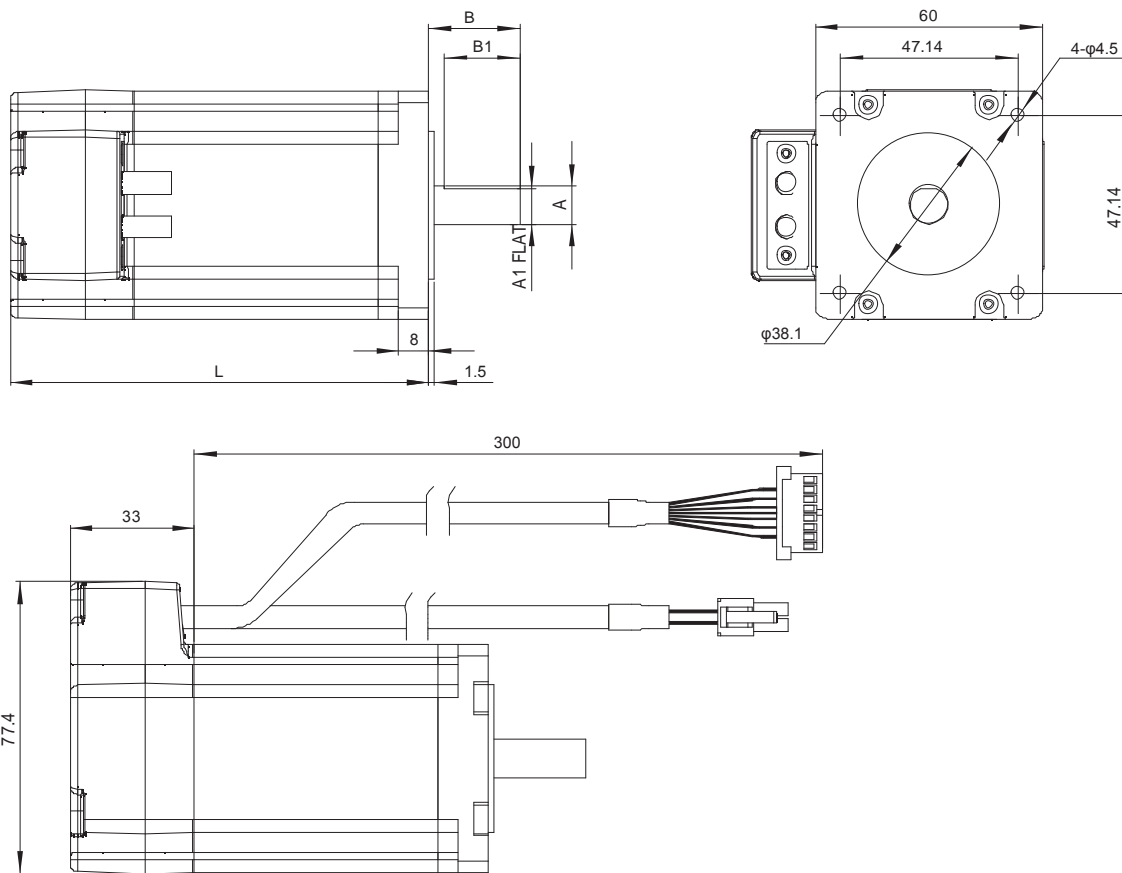

Type(Unit: mm)					
Model	A	A1	B	B1	L
AM24RS3DMA	φ 10	9.5	24	20	110
AM24RS3DMB	φ 8	7.5	20	15	110

5.5 Torque Curves

AM11RS Series

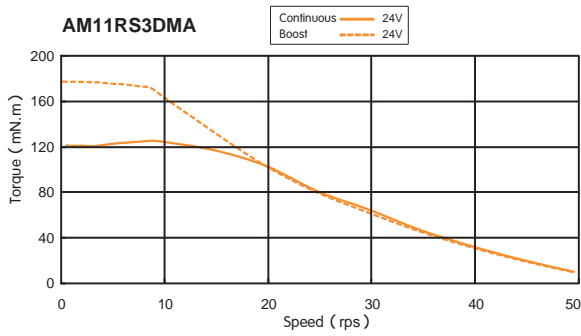
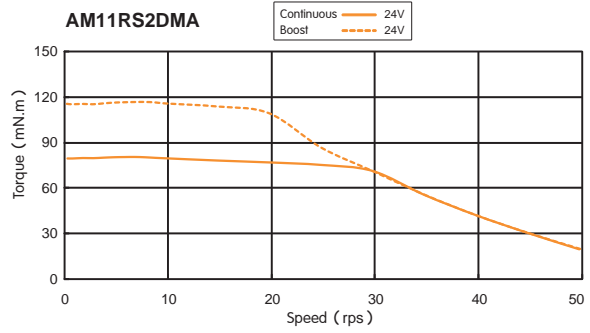
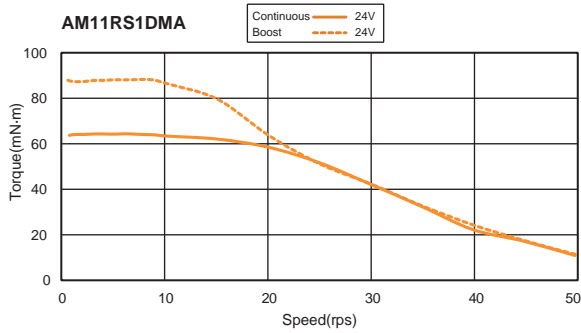

AM17RS Series

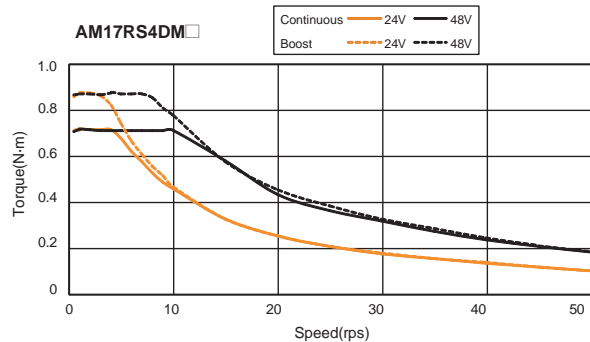
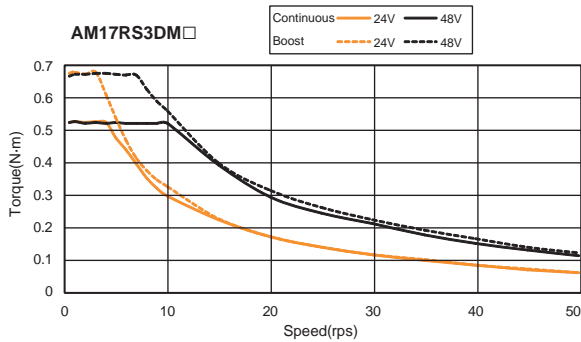
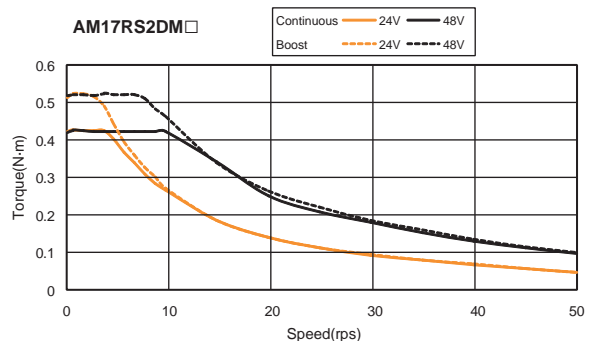
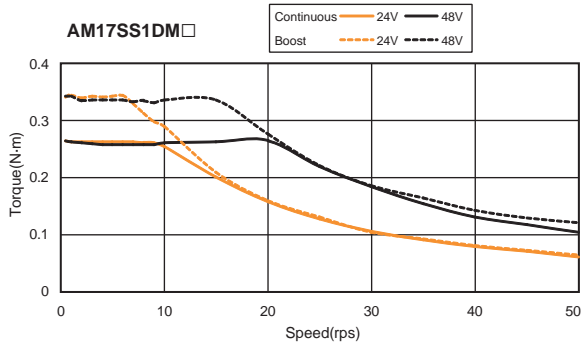

AM23RS Series

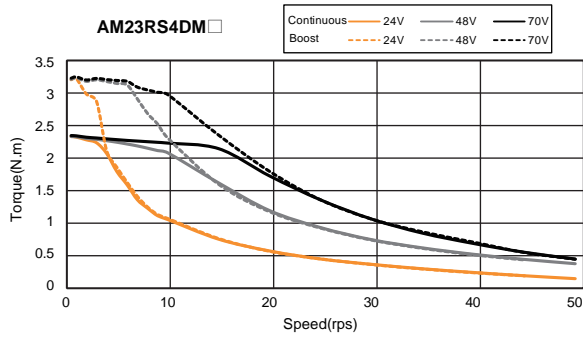
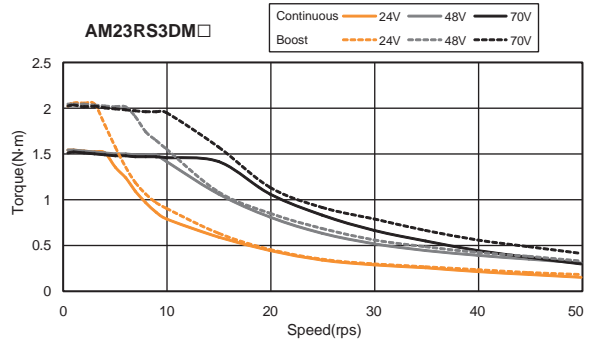
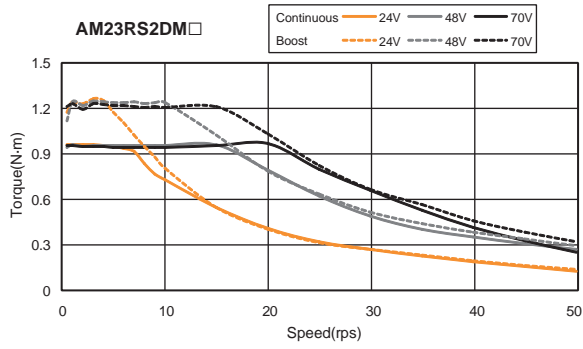

AM24RS Series

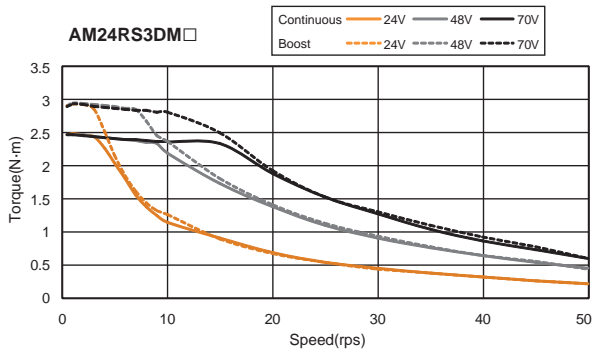

5.6 Motor Numbering System

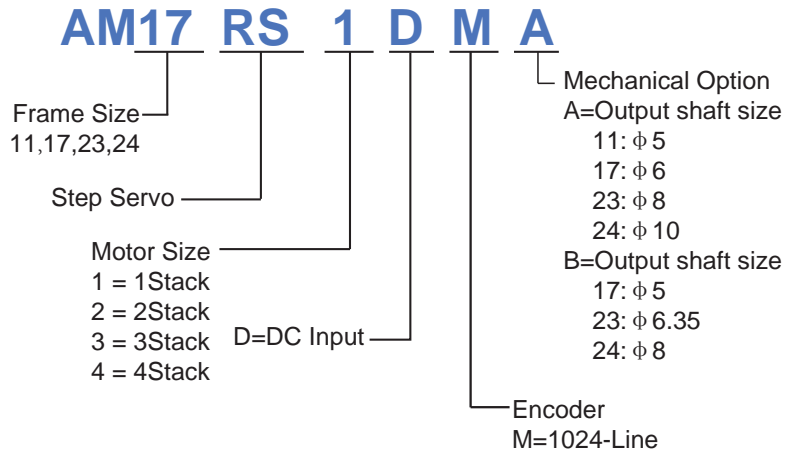

5.7 Drive Numbering System

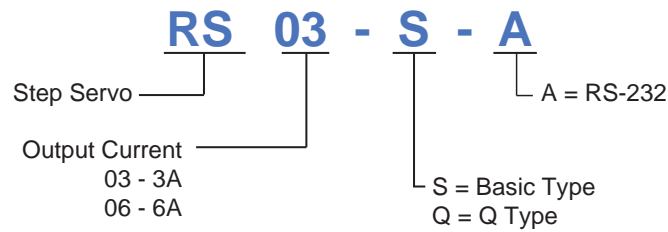

6. Optional Accessories (Sold separately)

P/N	Category	Technical Specification
MF150A24AG-V	Switching Power Supply	150W, 24V
MF320A48AG-V	Switching Power Supply	320W, 48V
RC880	Regeneration Clamp	80VDC Max. 50W
MS-USB-RS232-01	USB Converter	USB-RS232
1108-□□□	Cable	I/O Cable (for RS-S/Q drives)
2103-□□□	Cable	Motor Extension Cable for AM17/23/24RS motor
2109-□□□	Cable	Motor Extension Cable for AM11RS motor
2116-□□□	Cable	Encoder Extension Cable for AM17/23/24RS motor
2118-□□□	Cable	Encoder Extension Cable for AM11RS motor

Switching Power Supplier

MOONS' recommend to use following switching power supplies

P/N:MF150A24AG-V 150W,24VDC

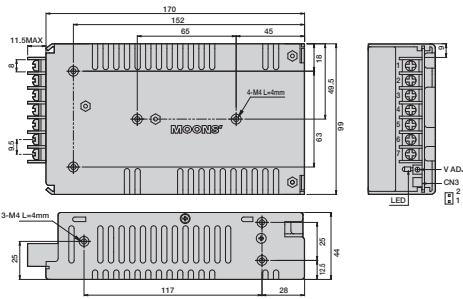

P/N:MF320A48AG-V 320W,48VDC

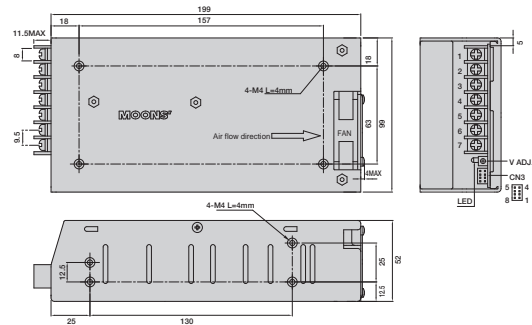

USB Converter

Model: MS-USB-RS232-01

Description: USB-RS232 converter



Motor Extension Cable for AM17/23/24/34RS motor

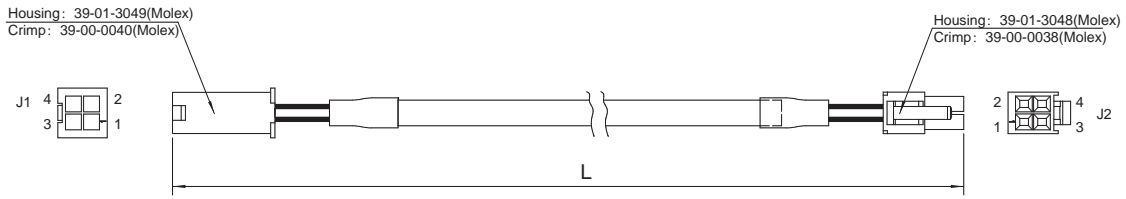

P/N	Length (L)
2103-100	1M
2103-300	3M
2103-500	5M
2103-1000	10M

Wiring Diagram		
PIN (J1)	Colour(Signal)	PIN (J2)
1	Blue (B-)	1
2	Red (B+)	2
3	Green (A-)	3
4	Black (A+)	4

Motor Extension Cable for AM11RS motor

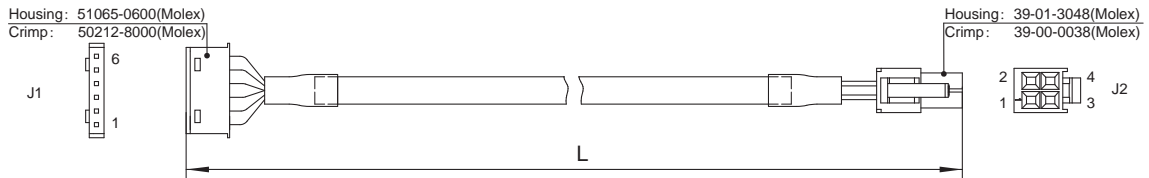

P/N	Length (L)
2109-100	1M
2109-300	3M
2109-500	5M
2109-1000	10M

Wiring Diagram		
PIN (J1)	Colour(Signal)	PIN (J2)
1	Blue (B-)	1
3	Red (B+)	2
4	Green (A-)	3
6	Black (A+)	4

Encoder Extension Cable for AM17/23/24RS motor

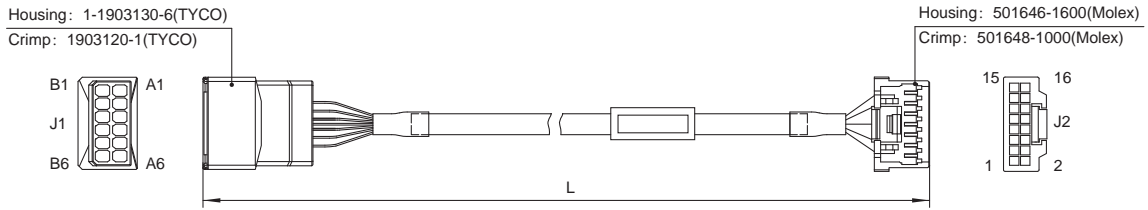

P/N	Length
2116-100	1M
2116-300	3M
2116-500	5M
2116-1000	10M

Wiring Diagram		
PIN (J1)	Colour(Signal)	PIN (J2)
A6	Blue (A+)	1
B6	Blue/Black (A-)	2
A5	Green (B+)	3
B5	Green/Black (B-)	4
A4	Yellow (Z+)	5
B4	Yellow/Black (Z-)	6
A3	Red (+5V)	7
B3	Black (GND)	8
	Brown (U+)	
	Brown/Black (U-)	
	Gray (V+)	
	Gray/Black (V-)	
A2	White (W+)	15
B2	White/Black (W-)	16
A1	Shield	10

Encoder Extension Cable for AM11RS motor

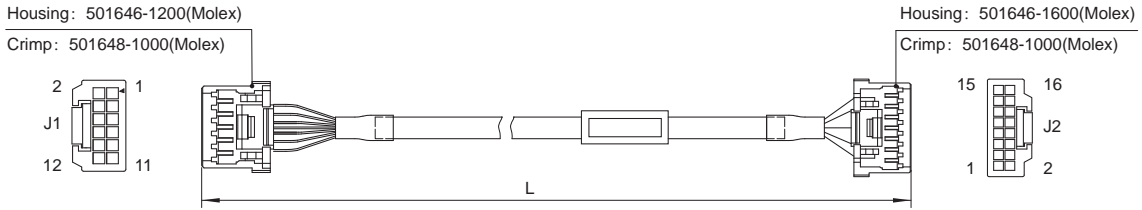

P/N	Length
2118-100	1M
2118-300	3M
2118-500	5M
2118-1000	10M

Wiring Diagram		
PIN (J1)	Colour(Signal)	PIN (J2)
10	Blue (A+)	1
9	Blue/Black (A-)	2
8	Green (B+)	3
7	Green/Black (B-)	4
6	Yellow (Z+)	5
5	Yellow/Black (Z-)	6
3	Red (+5V)	7
4	Black (GND)	8
	Brown (U+)	
	Brown/Black (U-)	
	Gray (V+)	
	Gray/Black (V-)	
1	White (W+)	15
2	White/Black (W-)	16
12	Shield	10

I/O Cable (for RS-S/Q drives)

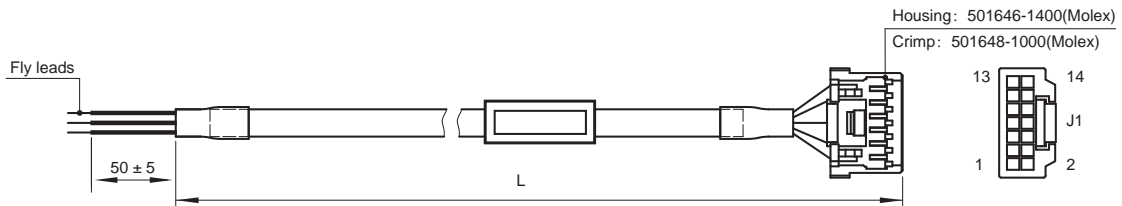

P/N	Length (L)
1108-030	30 CM
1108-100	1 M
1108-200	2 M

Wiring Diagram			
PIN (J1)	Colour(Signal)	PIN (J1)	Colour(Signal)
1	Blue (STEP+)	8	Black (XCOM)
2	Blue/Black (STEP-)	9	Brown (Y1+)
3	Green (DIR+)	10	Brown/Black (Y1-)
4	Green/Black (DIR-)	11	Gray (Y2+)
5	Yellow (X3)	12	Gray/Black (Y2-)
6	Yellow/Black (X4)	13	White (Y3+)
7	Shield	14	White/Black (Y3-)

7. Contacting MOONS'



■ MOONS' Headquarters

168 Mingjia Road, Minhang District, Shanghai 201107,
P.R. China
Tel: +86 (0)21 52634688
Fax: +86 (0)21 52634098

■ MOONS' International Trading Company

4/F, Building 30, 69 Guiqing Road, Cao He Jin Hi-Tech
Park, Shanghai 200233, P.R. China
Tel: +86 (0)21 64952755
Fax: +86 (0)21 64951993

■ Domestic Offices

Shenzhen

Room 2209, 22/F, Kerry Center, 2008 Renminnan Road,
Luohu District, Shenzhen 518001, P.R. China
Tel: +86 (0)755 25472080
Fax: +86 (0)755 25472081

Beijing

Room 816, Tower B, China Electronics Plaza, 3 Danling
Street, Haidian District, Beijing 100080, P.R. China
Tel: +86 (0)10 58753312
Fax: +86 (0)10 58752279

Nanjing

Room 1101-1102, Building 2, New Town Development
Center, No.126 Tianyuan Road, Moling Street,
Jiangning District, Nanjing 211106, P.R. China
Tel: +86 (0)25 52785841
Fax: +86 (0)25 52785485

Qingdao

Room 1012, Zhuoyue Tower, No.16 Fengcheng Road,
Shibei District, Qingdao 26000, P.R. China
Tel: +86 (0)532 80969935
Fax: +86 (0)532 80919938

Wuhan

Room 3001, World Trade Tower, 686 Jiefang Avenue,
Jianghan District, Wuhan 430022, P.R. China
Tel: +86 (0)27 85448742
Fax: +86 (0)27 85448355

Chengdu

Room 1917, Western Tower, 19, 4th Section of South People
Road, Wuhou District, Chengdu 610041, P.R. China
Tel: +86 (0)28 85268102
Fax: +86 (0)28 85268103

Xi'an

Room 1006, Tower D, Wangzuo International City,
1 Tangyan Road, Xi'an 710065, P.R. China
Tel: +86 (0)29 81870400
Fax: +86 (0)29 81870340

Ningbo

Room 309, Tower B, Taifu Plaza, 565 Jiangjia Road,
Jiangdong District, Ningbo, 315040, P.R. China
Tel: +86 (0)574 87052739
Fax: +86 (0)574 87052365

Guangzhou

Room 4006, Tower B, China Shine Plaza, 9 Linhe Xi Road,
Tianhe District, Guangzhou 510610, P.R. China
Tel: +86 (0)20 38010153
Fax: +86 (0)20 38103661

■ North America Company

MOONS' INDUSTRIES (AMERICA), INC.

1113 North Prospect Avenue, Itasca, IL 60143 USA
Tel: +1 630 8335940
Fax: +1 630 8335946

APPLIED MOTION PRODUCTS, INC.

404 Westridge Dr. Watsonville, CA 95076, USA
Tel: +1 831 7616555

LIN ENGINEERING, INC.

16245 Vineyard Blvd., Morgan Hill, CA 95037
Tel: +1 408 9190200
Fax: +1 408 9190201

■ European Company

MOONS' INDUSTRIES (EUROPE) S.R.L.

Via Torri Bianche n.1 20871 Vimercate(MB) Italy
Tel: +39 039 6260521
Fax: +39 039 9631409

■ South-East company

MOONS' INDUSTRIES (SOUTH-EAST ASIA) PTE. LTD.

33 Ubi Avenue 3 #08-23 Vertex Singapore 408868
Tel: +65 66341198
Fax: +65 66341138

■ Japan Company

MOONS' INDUSTRIES JAPAN CO., LTD.

Room 601, 6F, Shin Yokohama Koushin Building,
2-12-1, Shin-Yokohama, Kohoku-ku, Yokohama,
Kanagawa, 222-0033, Japan
Tel: +81 (0)45 4755788
Fax: +81 (0)45 4755787