

HT-Servo-Hochleistungsgetriebe ≤ 1'

HT High-Torque Servo Gearboxes ≤ 1'

Achsabstand 50 mm

Centre distance 50 mm

B-12 – B-13

Achsabstand 63 mm

Centre distance 63 mm

B-14 – B-15

Achsabstand 80 mm

Centre distance 80 mm

B-16 – B-17

Achsabstand 100 mm

Centre distance 100 mm

B-18 – B-19

Auswahl- und Belastungstabellen

Selection and load tables

B-20 – B-22

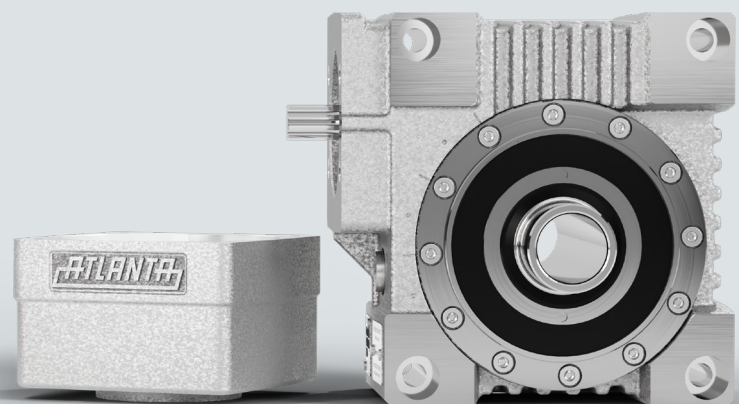
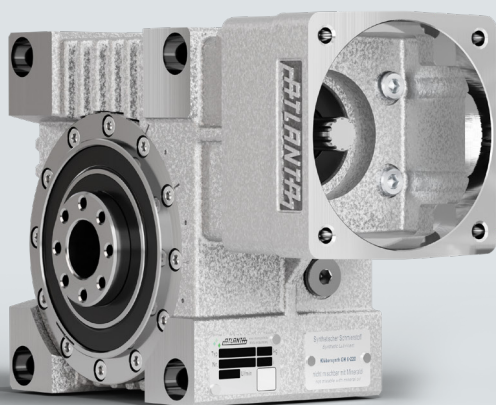

Achsabstand / Centre distance $a_0 = 50 \text{ mm}$

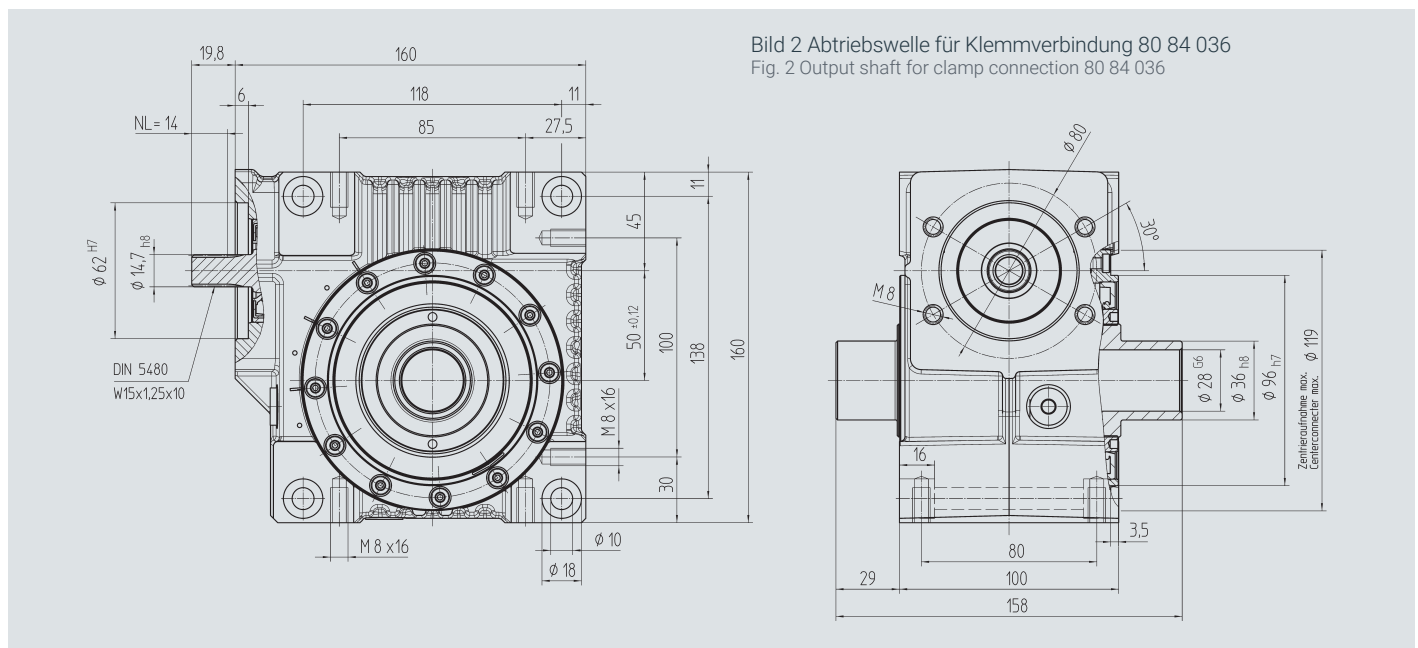
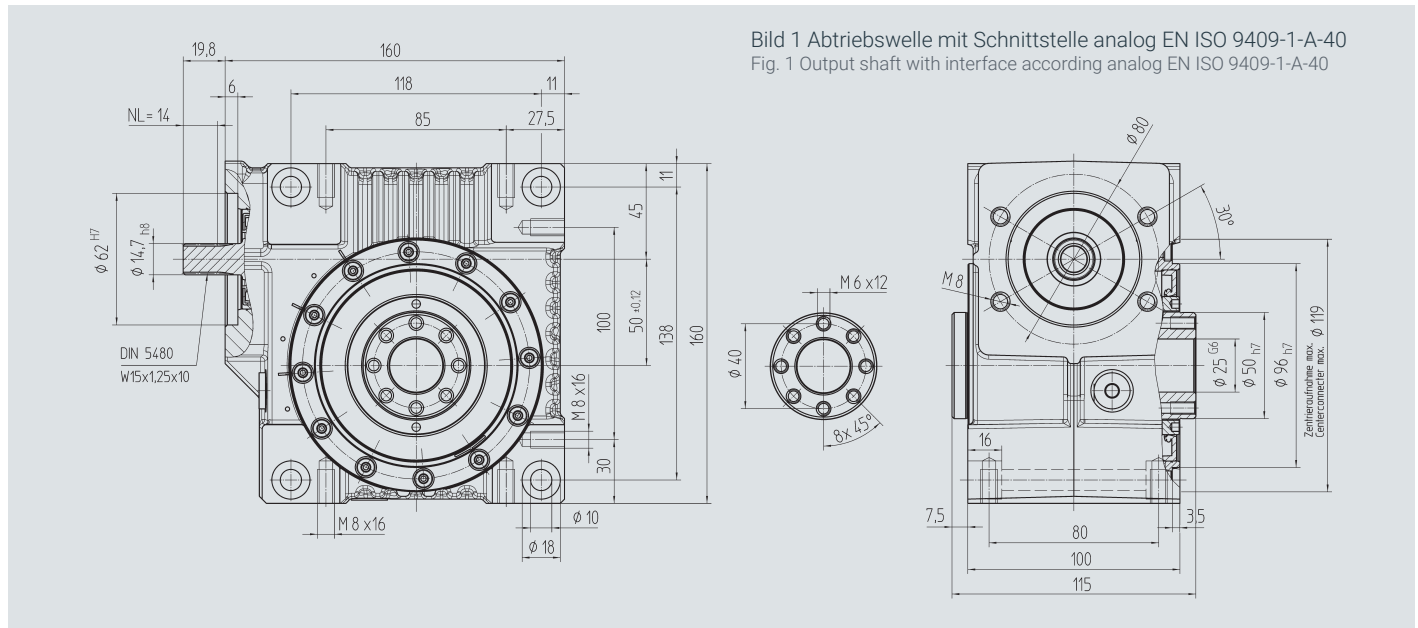

Best.-Nr. / Order code Bild 1 / Fig. 1	Bild 2 / Fig. 2	Übersetzung i Ratio i	kg	$J_{red} 10^{-4} \text{ kg m}^2$
98 03 005	98 13 005	4,75	7,0	0,8280
98 03 007	98 13 007	6,75	7,0	0,4140
98 03 009	98 13 009	9,25	7,0	0,3490
98 03 015	98 13 015	14,50	7,0	0,2800
98 03 020	98 13 020	19,50	7,0	0,1960
98 03 029	98 13 029	29,00	7,0	0,2694
98 03 039	98 13 039	39,00	7,0	0,2310
98 03 050	98 13 050	50,00	7,0	0,2140

Mit lebensmitteleuglichem Öl
Bestell-Nr. 98 03 1xx / 98 13 1xx

With suitable oil for food
Order code 98 03 1xx / 98 13 1xx

In ATEX-Ausführung mit lebensmitteleuglichem Öl
Bestell-Nr. 98 03 2xx / 98 13 2xx

In ATEX-Version with suitable oil for food
Order code 98 03 2xx / 98 13 2xx

Motorflansch / Motor flange

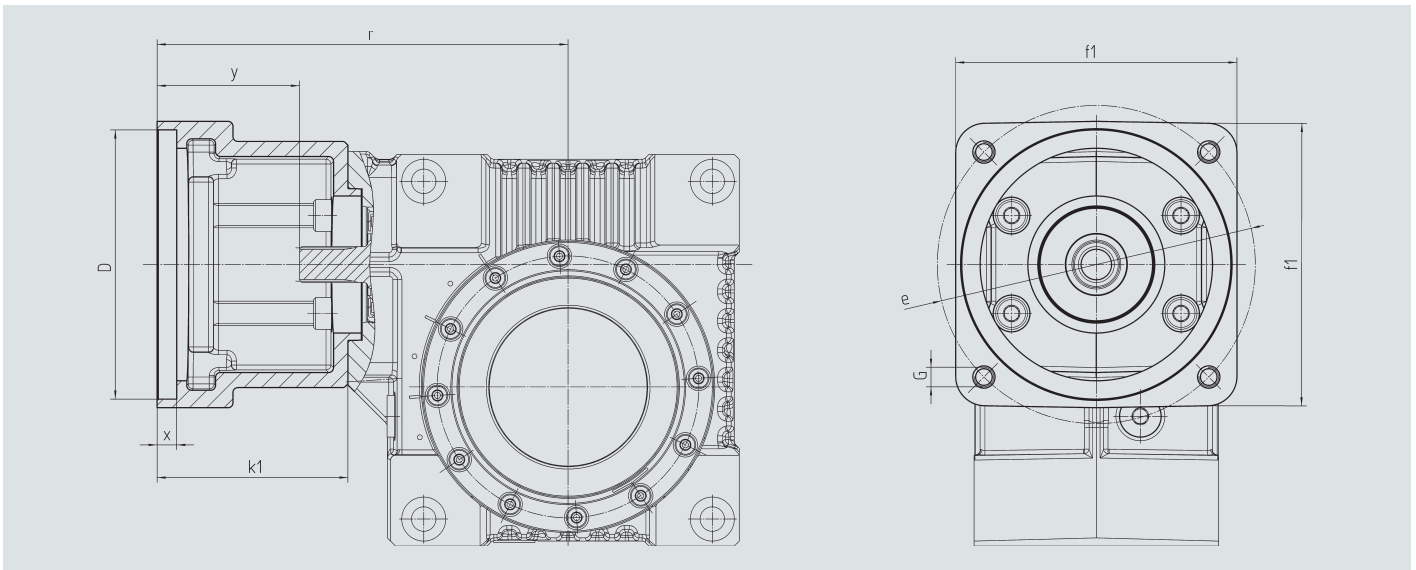

Achsabstand / Centre distance $a_0 = 50 \text{ mm}$

Bestell-Nr. Order code	D ^{G7}	k ₁	r	x	y	f ₁	e	G	kg
65 59 301	95,0	62	152	12,5	42	100	115	M8	0,60
65 59 302	50,0	62	152	10,0	42	100	70; 95; 115	M4; M6; M8	0,70
65 59 303	80,0	62	152	10,0	42	100	100	M6	0,65
65 59 304	95,0	78	168	10,0	58	115	130	M8	0,80
65 59 306	60,0	74	164	21,0	54	100	75; 90; 115	M5; M5; M8	0,90
65 59 307	70,0	70	160	21,0	50	100	90; 115	M6; M8	0,80
65 59 401	95,0	73	163	8,0	53	100	115	M8	0,75
65 59 402	110,0	78	168	8,0	58	115	130	M8	0,80
65 59 403	95,0	73	163	12,0	53	115	130	M8	0,75
65 59 404	110,0	73	163	12,0	53	115	130	M8	0,70
65 59 405	95,0	78	168	11,0	58	140	165	M10	1,20
65 59 406	110,0	78	168	11,0	58	140	165	M10	1,15
65 59 407	130,0	78	168	11,0	53	140	165	M10	1,00
65 59 409	130,0	98	188	14,0	78	140	165	M10	1,10
65 59 410	110,0	74	164	8,0	54	120	145	M8	1,00
65 59 411	110,0	84	174	8,0	64	120	145	M8	1,20
65 59 412	114,3	105	195	8,0	85	180	200	M12	3,70
65 59 413	114,3	139	229	8,0	119	180	200	M12	3,35
65 59 414	114,3	91	181	8,0	71	180	200	M12	2,65
65 59 415	110,0	89	179	8,0	69	120	145	M8	1,30

Bestellung besteht aus Grundgetriebe 98 03 0xx / 98 13 0xx und Flansch 65 59 3xx bzw. 4xx.
The order should contain gearbox 98 03 0xx / 98 13 0xx and flange 65 59 3xx or 4xx.

Achsabstand / Centre distance $a_0 = 63 \text{ mm}$



Bild 1 Abtriebswelle mit Schnittstelle analog EN ISO 9409-1-A-50
Fig. 1 Output shaft with interface according analog EN ISO 9409-1-A-50



Bild 2 Abtriebswelle für Klemmverbindung 80 85 050
Fig. 2 Output shaft for clamp connection 80 85 050

Best.-Nr. / Order code	Übersetzung i		
Bild 1 / Fig. 1	Bild 2 / Fig. 2	Ratio i	$J_{red} 10^{-4} \text{ kg m}^2$
98 04 005	98 14 005	4,75	12,0
98 04 007	98 14 007	6,75	12,0
98 04 009	98 14 009	9,25	12,0
98 04 015	98 14 015	14,50	12,0
98 04 020	98 14 020	19,50	12,0
98 04 029	98 14 029	29,00	12,0
98 04 039	98 14 039	39,00	12,0
98 04 052	98 14 052	52,00	12,0

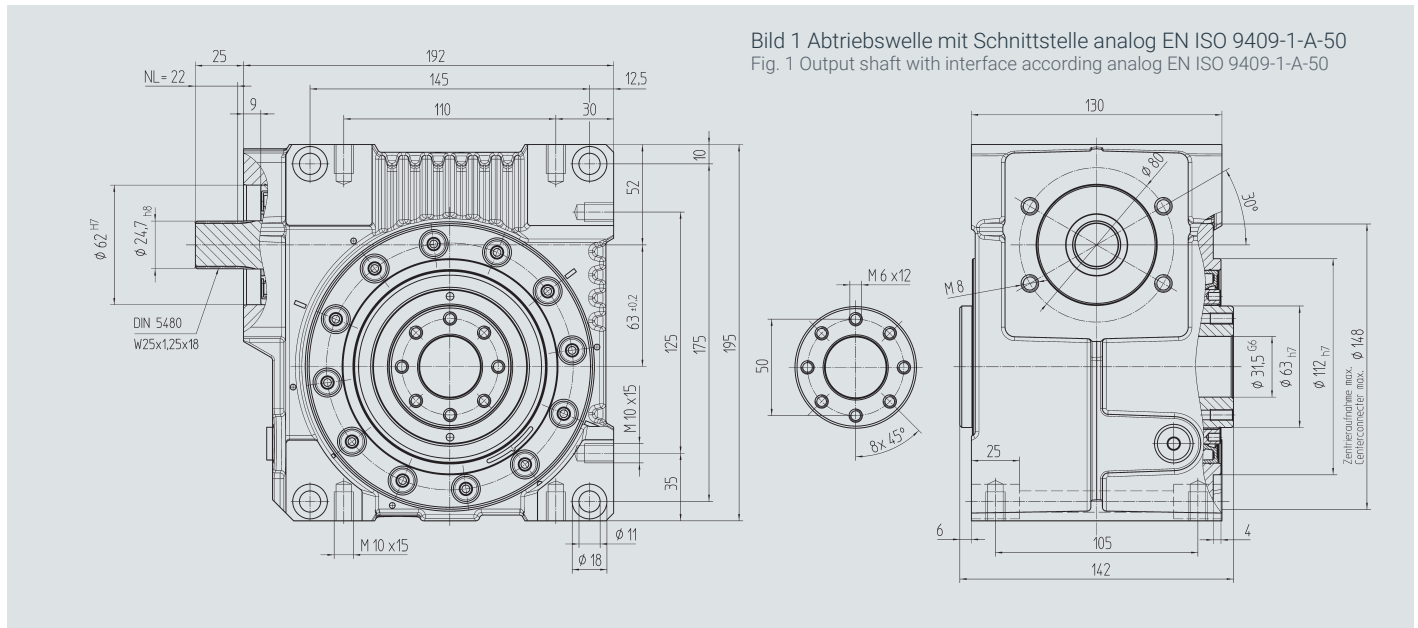
Mit lebensmitteltauglichem Öl
Bestell-Nr. 98 04 1xx / 98 14 1xx

With suitable oil for food
Order code 98 04 1xx / 98 14 1xx

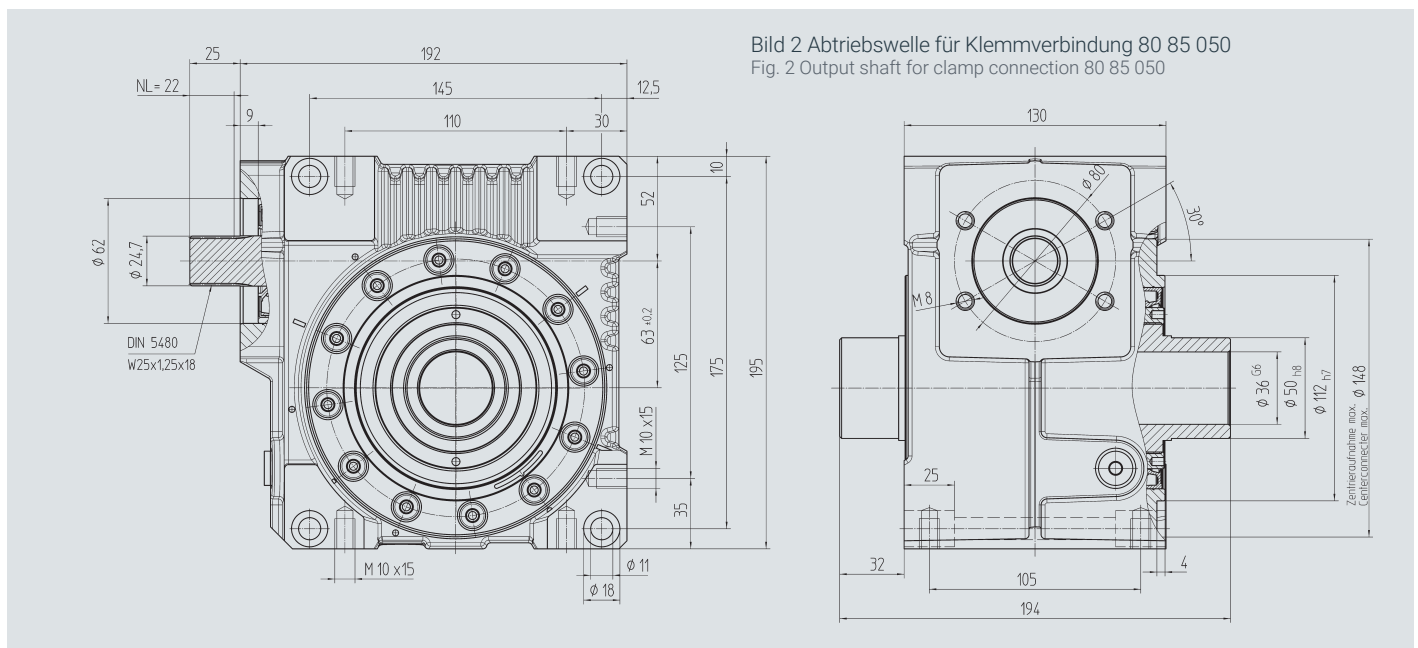
In ATEX-Ausführung mit lebensmitteltauglichem Öl
Bestell-Nr. 98 04 2xx / 98 14 2xx

In ATEX-Version with suitable oil for food
Order code 98 04 2xx / 98 14 2xx

Motorflansch / Motor flange

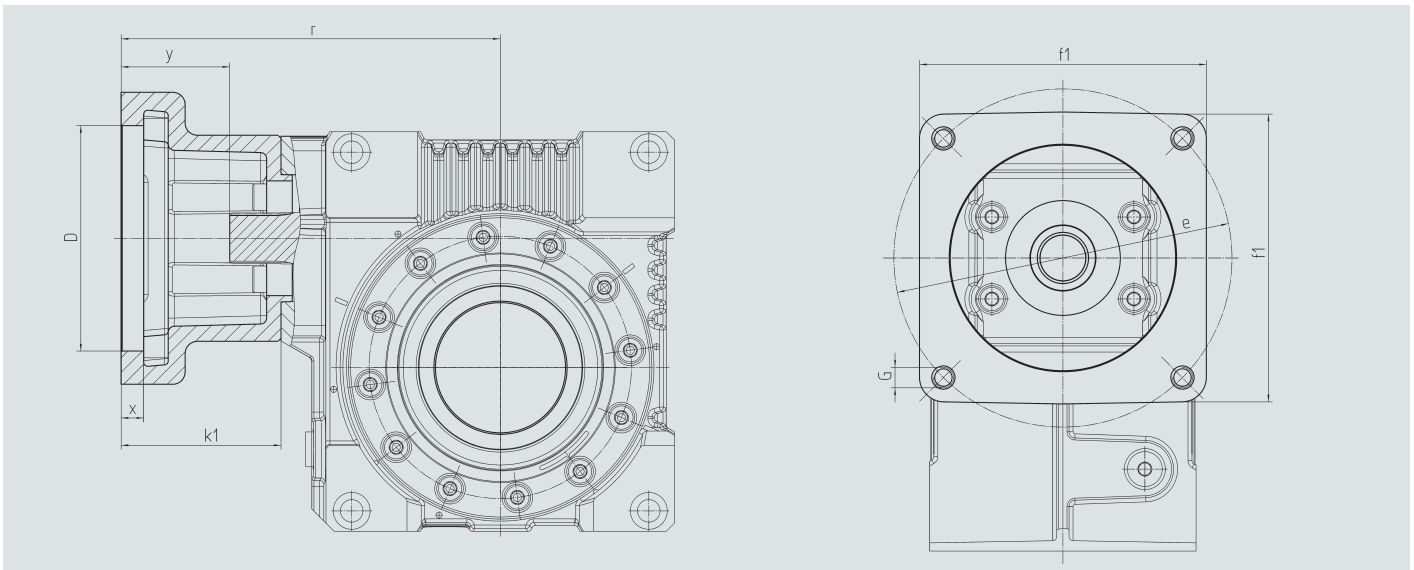

Achsabstand / Centre distance $a_0 = 63 \text{ mm}$

Bestell-Nr. Order code	D ^{G7}	k ₁	r	x	y	f ₁	e	G	kg
65 59 301	95,0	62	169	12,5	37	100	115	M8	0,60
65 59 302	50,0	62	169	10,0	37	100	70; 95; 115	M4; M6; M8	0,70
65 59 303	80,0	62	169	10,0	37	100	100	M6	0,65
65 59 304	95,0	78	185	10,0	53	115	130	M8	0,80
65 59 306	60,0	74	181	21,0	49	100	75; 90; 115	M5; M5; M8	0,90
65 59 307	70,0	70	177	21,0	45	100	90; 115	M6; M8	0,80
65 59 401	95,0	73	180	8,0	48	100	115	M8	0,75
65 59 402	110,0	78	185	8,0	53	115	130	M8	0,80
65 59 403	95,0	73	180	12,0	48	115	130	M8	0,75
65 59 404	110,0	73	180	12,0	48	115	130	M8	0,70
65 59 405	95,0	78	185	11,0	53	140	165	M10	1,20
65 59 406	110,0	78	185	11,0	53	140	165	M10	1,15
65 59 407	130,0	78	185	11,0	53	140	165	M10	1,00
65 59 409	130,0	98	205	14,0	78	140	165	M10	1,10
65 59 410	110,0	74	181	8,0	49	120	145	M8	1,00
65 59 411	110,0	84	191	8,0	59	120	145	M8	1,20
65 59 412	114,3	105	212	8,0	80	180	200	M12	3,70
65 59 413	114,3	139	246	8,0	114	180	200	M12	3,35
65 59 414	114,3	91	198	8,0	66	180	200	M12	2,65
65 59 415	110,0	89	196	8,0	64	120	145	M8	1,30

Bestellung besteht aus Grundgetriebe 98 04 0xx / 98 14 0xx und Flansch 65 59 3xx bzw. 4xx.
The order should contain gearbox 98 04 0xx / 98 14 0xx and flange 65 59 3xx or 4xx.

Achsabstand / Centre distance $a_0 = 80 \text{ mm}$

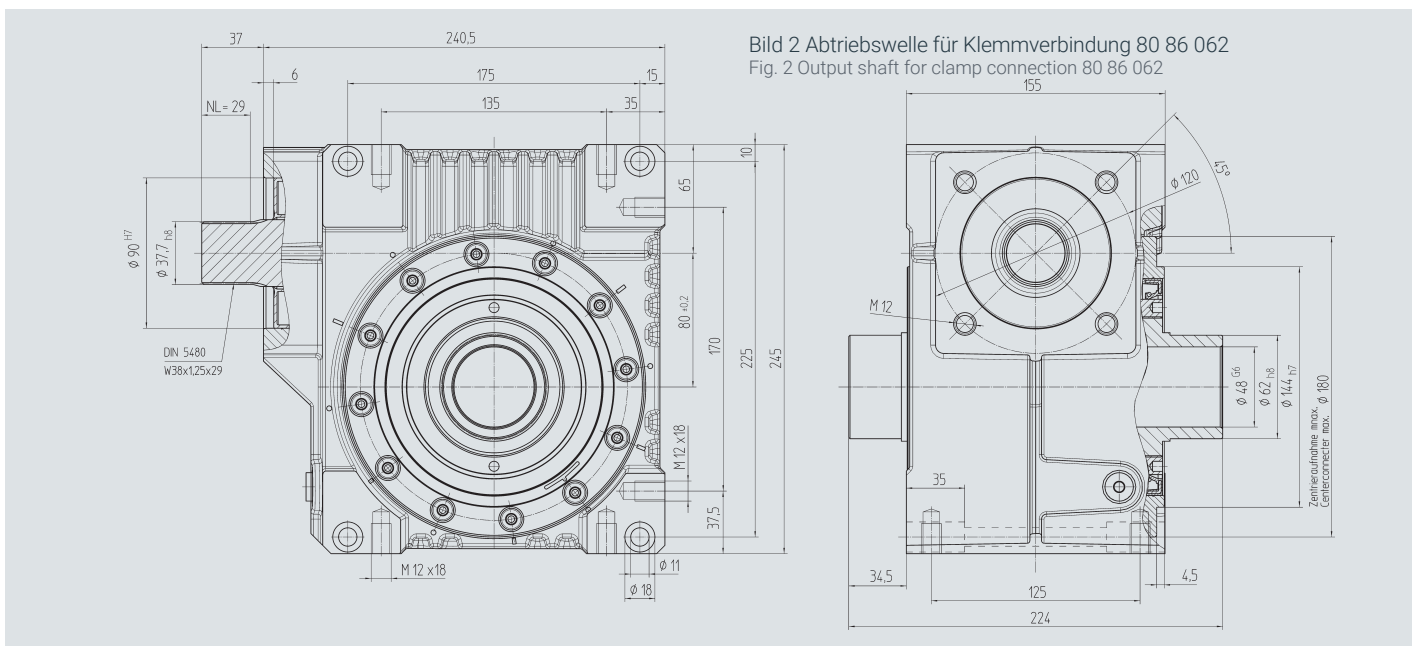
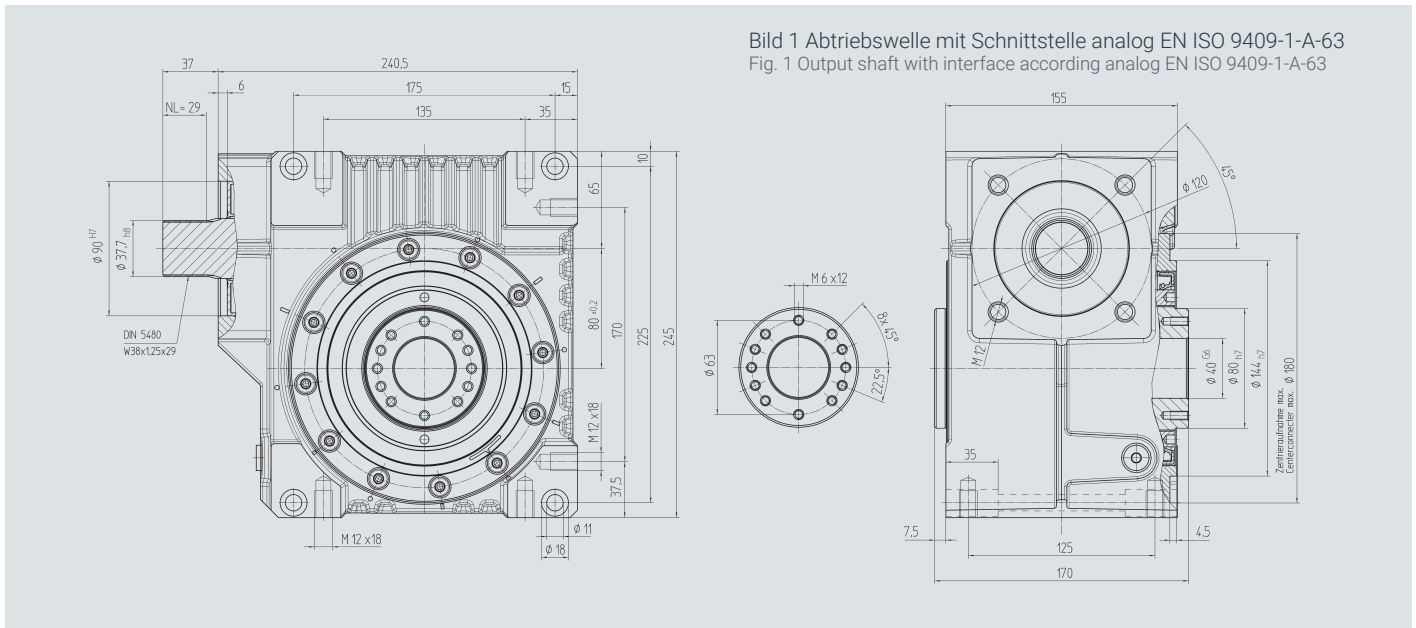

Best.-Nr. / Order code Bild 1 / Fig. 1	Bild 2 / Fig. 2	Übersetzung i Ratio i	 kg	$J_{red} 10^{-4} \text{ kg m}^2$
98 05 005	98 15 005	4,75	23,0	9,6180
98 05 007	98 15 007	6,75	23,0	6,0910
98 05 009	98 15 009	9,25	23,0	4,7650
98 05 015	98 15 015	14,50	23,0	5,3080
98 05 020	98 15 020	19,50	23,0	3,9350
98 05 029	98 15 029	29,00	23,0	4,0500
98 05 039	98 15 039	39,00	23,0	4,1800
98 05 052	98 15 052	52,00	23,0	3,7140

Mit lebensmitteleuglichem Öl
Bestell-Nr. 98 05 1xx / 98 15 1xx

With suitable oil for food
Order code 98 05 1xx / 98 15 1xx

In ATEX-Ausführung mit lebensmitteleuglichem Öl
Bestell-Nr. 98 05 2xx / 98 15 2xx

In ATEX-Version with suitable oil for food
Order code 98 05 2xx / 98 15 2xx

Motorflansch / Motor flange

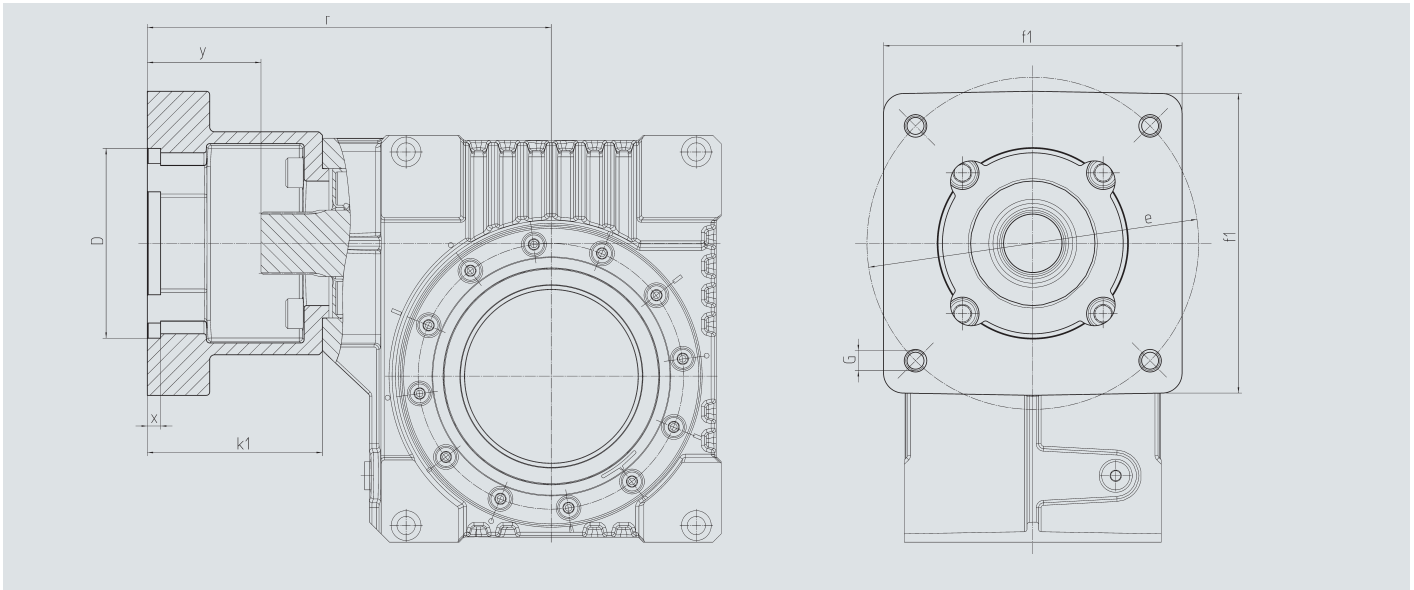

Achsabstand / Centre distance $a_0 = 80 \text{ mm}$

Bestell-Nr. Order code	D ^{G7}	k ₁	r	x	y	f ₁	e	G	kg
65 59 501	110,0	92,0	230,0	8,0	55,0	140	165	M10	2,00
65 59 502	130,0	92,0	230,0	8,0	55,0	140	165	M10	1,90
65 59 503	180,0	122,0	260,0	8,0	85,0	192	215	M12	3,40
65 59 504	180,0	127,0	265,0	8,0	90,0	192	215	M12	3,80
65 59 505	180,0	112,0	250,0	10,0	75,0	192	215	M12	2,70
65 59 506	130,0	112,0	250,0	10,0	75,0	192	215	M12	3,00
65 59 507	130,0	112,0	250,0	10,0	75,0	140	165	M10	2,50
65 59 508	110,0	90,0	228,0	8,0	53,0	140	145	M8	2,00
65 59 509	110,0	108,5	246,5	8,0	71,5	140	145	M8	2,50
65 59 510	114,3	129,5	267,5	8,0	92,5	180	200	M12	5,00
65 59 511	114,3	163,5	301,5	8,0	126,5	180	200	M12	4,20
65 59 512	114,3	105,5	243,5	8,0	68,5	180	200	M12	3,50
65 59 513	110,0	113,5	251,5	8,0	76,5	140	145	M8	2,70

Bestellung besteht aus Grundgetriebe 98 05 0xx / 98 15 0xx und Flansch 65 59 5xx.
The order should contain gearbox 98 05 0xx / 98 15 0xx and flange 65 59 5xx.

Achsabstand / Centre distance $a_0 = 100$ mm

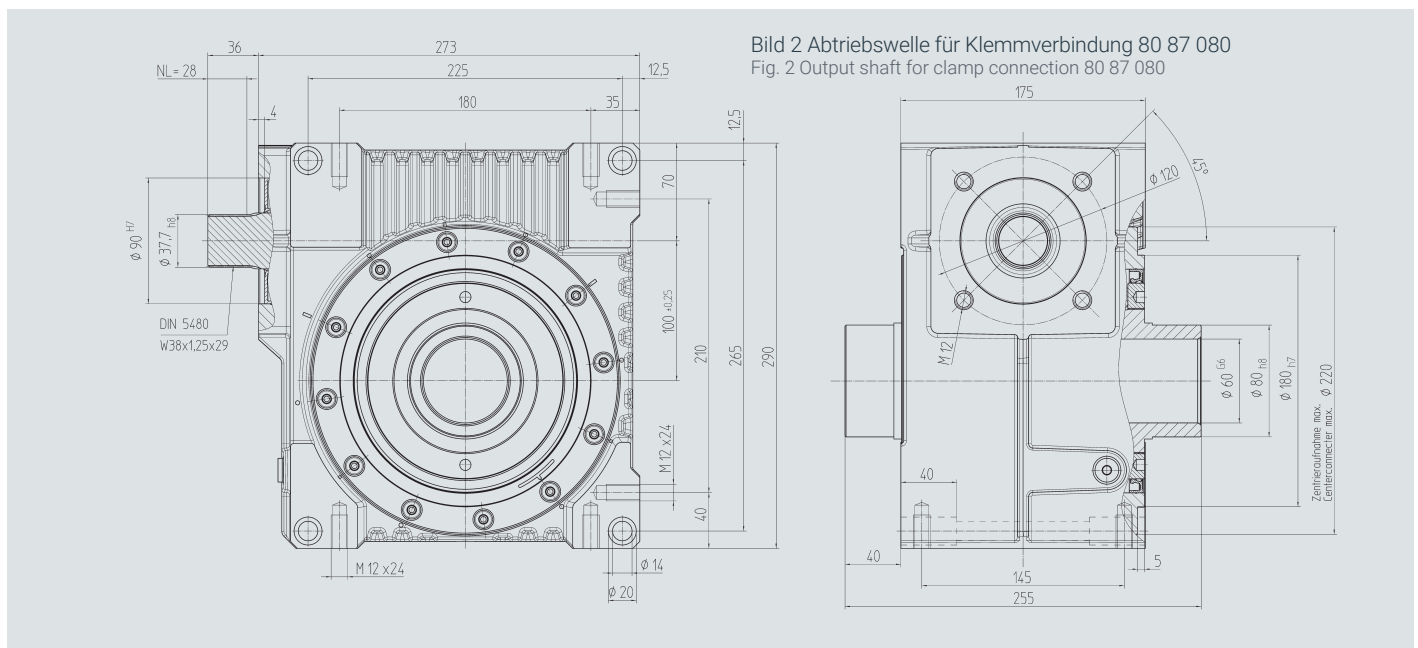
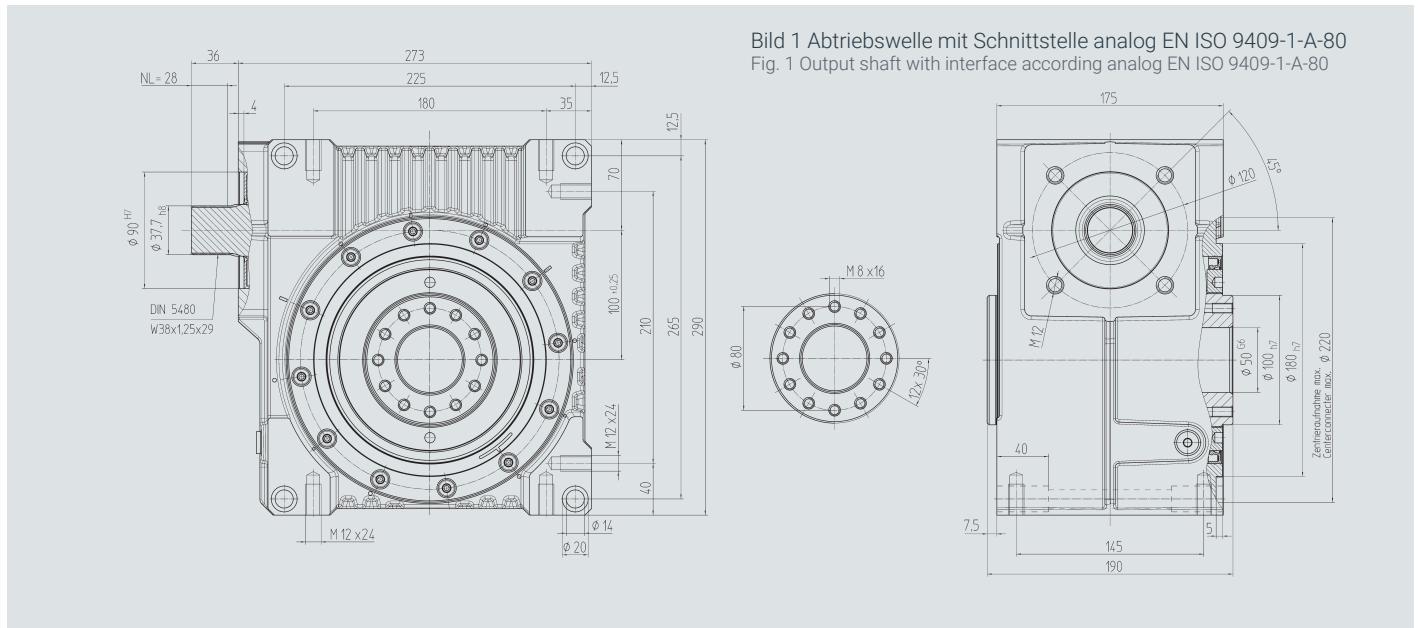

Best.-Nr. / Order code	Übersetzung i		
Bild 1 / Fig. 1	Ratio i	kg	$J_{red} 10^{-4} \text{ kg m}^2$
98 06 005	4,75	38,0	22,9320
98 06 007	6,75	38,0	12,8835
98 06 009	9,25	38,0	8,0975
98 06 015	14,50	38,0	7,2190
98 06 020	19,50	38,0	5,4030
98 06 029	29,00	38,0	4,7207
98 06 039	39,00	38,0	8,4300
98 06 052	52,00	38,0	9,7400

Mit lebensmitteltauglichem Öl
Bestell-Nr. 98 06 1xx / 98 16 1xx

With suitable oil for food
Order code 98 06 1xx / 98 16 1xx

In ATEX-Ausführung mit lebensmitteltauglichem Öl
Bestell-Nr. 98 06 2xx / 98 16 2xx

In ATEX-Version with suitable oil for food
Order code 98 06 2xx / 98 16 2xx

Motorflansch / Motor flange

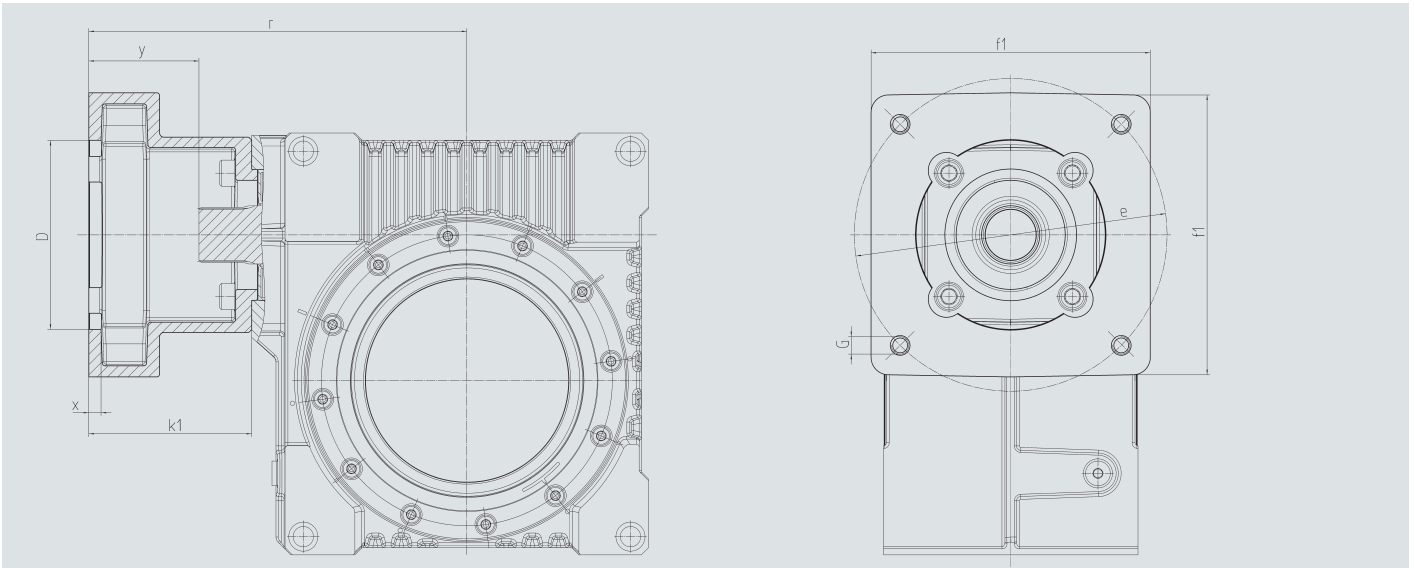

Achsabstand / Centre distance $a_0 = 100$ mm

Bestell-Nr. Order code	D ^{G7}	k ₁	r	x	y	f ₁	e	G	kg
65 59 501	110,0	92,0	240,0	8,0	55,0	140	165	M10	2,00
65 59 502	130,0	92,0	240,0	8,0	55,0	140	165	M10	1,90
65 59 503	180,0	122,0	270,0	8,0	85,0	192	215	M12	3,40
65 59 504	180,0	127,0	275,0	8,0	90,0	192	215	M12	3,80
65 59 505	180,0	112,0	260,0	10,0	75,0	192	215	M12	2,70
65 59 506	130,0	112,0	260,0	10,0	75,0	192	215	M12	3,00
65 59 507	130,0	112,0	260,0	10,0	75,0	140	165	M10	2,50
65 59 508	110,0	90,0	238,0	8,0	53,0	140	145	M8	2,00
65 59 509	110,0	108,5	256,5	8,0	71,5	140	145	M8	2,50
65 59 510	114,3	129,5	277,5	8,0	92,5	180	200	M12	5,00
65 59 511	114,3	163,5	311,5	8,0	126,5	180	200	M12	4,20
65 59 512	114,3	105,5	253,5	8,0	68,5	180	200	M12	3,50
65 59 513	110,0	113,5	253,5	8,0	76,5	140	145	M8	2,70

Bestellung besteht aus Grundgetriebe 98 06 0xx / 98 16 0xx und Flansch 65 59 5xx.
The order should contain gearbox 98 06 0xx / 98 16 0xx and flange 65 59 5xx.

Tabellenwerte basieren auf der Verschleiß- bzw. Flanken-
grenzleistung bei 12 000 h Vollast und dem Einsatz im Servo-Be-
trieb. Vergleichen Sie hierzu unsere Betriebs- und Wartungsan-
leitung im Internet unter **www.atlantagmbh.de**. Bei Vollast-Dau-
erbetrieb muss u.U. die Temperatur-Grenzleistung berücksichtigt
werden! (Gegebenenfalls bitte Rücksprache)

T_{2max} = statisches Drehmoment gegen Zahnbruch, T₁ = Antriebs-
moment in Nm, T₂ = Abtriebsmoment in Nm.

The values in the tables are based upon wear or maximum flank
load at 12,000 h full load and on servo-operation. Please see here
for also our manual on the internet page **www.atlantagmbh.de**.
With continuous full-load operation it may be necessary to consider
temperature limits! (Please ask us, if in doubt.)

T_{2max} = static torque to avoid tooth fracture, T₁ = input torque in
Nm, T₂ = output torque in Nm.

Bestell-Nr. Order code	a ₀ (mm)	i	T _{2max}	Antriebsdrehzahl / Driving speed n ₁ in min ⁻¹											
				250		500		750		1000		1500		2000	
				T ₁ (Nm)	T ₂ (Nm)	T ₁ (Nm)	T ₂ (Nm)	T ₁ (Nm)	T ₂ (Nm)	T ₁ (Nm)	T ₂ (Nm)	T ₁ (Nm)	T ₂ (Nm)	T ₁ (Nm)	T ₂ (Nm)
98 03 003 98 13 003	50	3,00*													
98 03 005 98 13 005		4,75	820	17,4	73	22,7	97	22,7	97	24,4	105	24,6	105	24,8	105
98 03 007 98 13 007		6,75	600	10,8	63	14,1	84	14,8	88	15,7	94	17,1	103	17,1	103
98 03 009 98 13 009		9,25	410	7,2	53	9,4	72	9,8	76	10,4	81	11,1	87	11,9	93
98 03 015 98 13 015		14,50	520	5,5	64	7,1	85	7,5	90	8,0	97	8,7	105	8,9	107
98 03 020 98 13 020		19,50	370	3,6	50	4,6	67	4,9	72	5,1	75	5,5	82	5,8	87
98 03 029 98 13 029		29,00	450	2,9	54	3,7	72	3,9	78	4,0	82	4,4	90	4,7	95
98 03 039 98 13 039		39,00	300	2,7	58	3,4	78	3,6	84	3,8	90	4,0	97	4,2	102
98 03 050 98 13 050		50,00	220	2,3	47	2,8	63	2,8	66	2,9	70	3,1	75	3,3	80
98 04 003 98 14 003	63	3,00*													
98 04 005 98 14 005		4,75	1500	56,3	244	58,4	255	61,8	270	61,9	270	58,7	255	56,1	242
98 04 007 98 14 007		6,75	1120	32,3	194	41,9	255	44,2	270	44,2	270	41,8	255	39,9	242
98 04 009 98 14 009		9,25	750	16,2	128	21,3	172	23,0	187	23,9	195	24,6	202	24,6	202
98 04 015 98 14 015		14,50	900	16,7	198	20,3	247	22,1	270	22,1	270	22,1	270	21,7	265
98 04 020 98 14 020		19,50	750	8,4	130	10,7	172	11,6	187	12,0	195	12,5	202	13,4	217
98 04 029 98 14 029		29,00	970	10,3	206	12,6	262	13,6	285	14,6	307	15,7	330	15,2	317
98 04 039 98 14 039		39,00	670	6,3	159	7,8	210	8,2	225	8,8	240	9,6	262	9,8	270
98 04 052 98 14 052		52,00	450	3,7	106	4,5	142	4,9	157	5,3	172	5,7	187	6,1	200
98 05 003 98 15 003	80	3,00*													
98 05 005 98 15 005		4,75	3000	154,3	680	142,3	630	128,9	570	122,2	540	112,5	495	107,3	470
98 05 007 98 15 007		6,75	2100	97,8	603	101,3	630	91,6	570	86,8	540	79,8	495	76,1	470
98 05 009 98 15 009		9,25	1650	56,3	465	66,2	555	66,1	555	64,3	540	59,0	495	56,2	470
98 05 015 98 15 015		14,50	1950	52,4	646	53,9	675	53,7	675	50,1	630	44,1	555	41,3	517
98 05 020 98 15 020		19,50	1500	32,9	530	33,7	555	36,3	600	36,2	600	32,6	540	31,4	520
98 05 029 98 15 029		29,00	1800	34,4	747	35,0	780	36,8	825	35,4	795	32,7	735	31,3	700
98 05 039 98 15 039		39,00	1270	22,5	617	22,7	645	24,0	690	25,6	735	25,0	720	23,9	685
98 05 052 98 15 052		52,00	900	9,4	325	9,9	360	10,7	390	11,2	412	12,3	450	12,7	465
98 06 005 98 16 005	100	4,75	4950	351,4	1564	295,9	1320	269,3	1200	253,6	1125	231,5	1027	220,6	975
98 06 007 98 16 007		6,75	3450	190,8	1195	197,7	1245	178,6	1125	172,2	1080	157,9	990	152,0	950
98 06 009 98 16 009		9,25	2850	141,4	1192	146,5	1245	132,2	1125	127,2	1080	116,6	990	112,2	950
98 06 015 98 16 015		14,50	3070	105,1	1338	108,3	1395	102,3	1320	94,4	1215	83,9	1080	80,3	1030
98 06 020 98 16 020		19,50	2700	77,8	1292	79,9	1350	77,0	1305	71,7	1215	63,7	1080	60,9	1030
98 06 029 98 16 029		29,00	3450	73,0	1654	74,8	1725	69,2	1605	65,5	1515	55,2	1275	54,4	1250
98 06 039 98 16 039		39,00	2470	52,8	1551	53,7	1620	51,0	1545	49,4	1500	44,5	1350	42,7	1290
98 06 052 98 16 052		52,00	1650	31,1	1139	30,1	1140	32,2	1230	33,4	1275	30,8	1177	29,5	1125

* auf Anfrage / on request

																Antriebsdrehzahl / Driving speed n ₁ in min ⁻¹											
2500		3000		3500		4000		4500		5000		5500		6000													
T ₁ (Nm)	T ₂ (Nm)	T ₁ (Nm)	T ₂ (Nm)	T ₁ (Nm)	T ₂ (Nm)	T ₁ (Nm)	T ₂ (Nm)	T ₁ (Nm)	T ₂ (Nm)	T ₁ (Nm)	T ₂ (Nm)	T ₁ (Nm)	T ₂ (Nm)	T ₁ (Nm)	T ₂ (Nm)												
25,0	105	25,2	105	24,5	101	23,7	97	23,2	94	22,7	91	21,4	85	20,4	80												
17,2	103	17,3	103	16,9	100	16,5	97	16,1	94	15,7	91	14,9	86	14,1	81												
12,6	99	13,3	105	13,3	105	13,4	105	13,0	101	12,6	97	11,9	92	11,4	87												
9,1	110	9,3	112	9,4	112	9,4	112	9,5	112	9,6	112	9,1	106	8,7	100												
6,1	92	6,5	97	6,5	97	6,5	97	6,5	97	6,6	97	6,2	91	5,9	86												
4,9	100	5,2	105	5,2	105	5,3	105	5,1	101	5,0	97	4,7	91	4,5	86												
4,4	107	4,6	112	4,6	112	4,6	112	4,6	112	4,7	112	4,5	105	4,3	100												
3,4	85	3,6	90	3,6	90	3,6	90	3,6	90	3,6	90	3,7	93	3,8	95												
53,4	230	50,8	217	49,3	210	47,8	202	44,4	186	41,3	172																
38,1	230	36,1	217	35,1	210	34,0	202	31,7	187	29,7	174	27,9	163														
24,6	202	24,7	202	24,0	196	23,4	189	21,9	176	20,7	165	19,6	156	18,6	147												
21,4	260	21,1	255	20,6	248	20,1	240	18,7	222	17,6	207	16,6	194														
14,4	232	15,4	247	14,9	240	14,5	232	13,7	217	12,9	204	12,2	192	11,7	181												
14,6	305	14,1	292	13,9	285	13,6	277	12,8	257	12,0	239	11,3	223														
10,2	277	10,5	285	10,5	285	10,7	285	10,0	266	9,5	249	9,0	234	8,6	221												
6,5	212	6,9	225	7,2	233	7,4	240	7,2	232	6,9	218	6,6	205	6,3	194												
102,2	445	96,8	420	88,4	381	79,9	343																				
72,4	445	68,6	420	63,0	384	57,3	347	53,0	320	49,4	297																
53,5	445	50,7	420	46,8	386	42,8	352	39,8	326	37,3	303	35,0	283														
38,5	480	35,6	442	32,8	405	30,0	368	27,8	340	25,9	315																
30,3	500	29,2	480	27,1	442	24,9	404	23,1	374	21,7	349	20,4	326														
29,9	665	28,5	630	26,3	576	24,0	523	22,3	482																		
22,8	650	21,7	615	20,1	566	18,5	517	17,3	478	16,3	445	15,3	417														
13,2	480	13,7	495	13,7	495	13,8	494	13,0	462	12,3	432	11,6	407														
209,5	922	198,4	870																								
146,1	910	140,2	870	126,5	782	103,8	639																				
107,9	910	103,5	870	94,3	789	78,3	654	79,9	663	74,5	616																
76,6	980	73,0	930	66,0	838	60,4	763																				
58,2	980	55,5	930	50,6	845	46,6	775	43,2	715	0,8	663																
53,6	1225	52,8	1200	47,9	1081																						
41,0	1230	39,2	1170	35,8	1061	29,9	881	30,6	896																		
28,2	1072	26,9	1020	24,8	931	23,0	856	21,5	792	18,8	691																

Verzahnungswirkungsgrad für Servo-Schneckengetriebe bei treibender Schnecke und unter Volllast.
Gearing efficiency of servo worm gearboxes with driving worm and under full load.

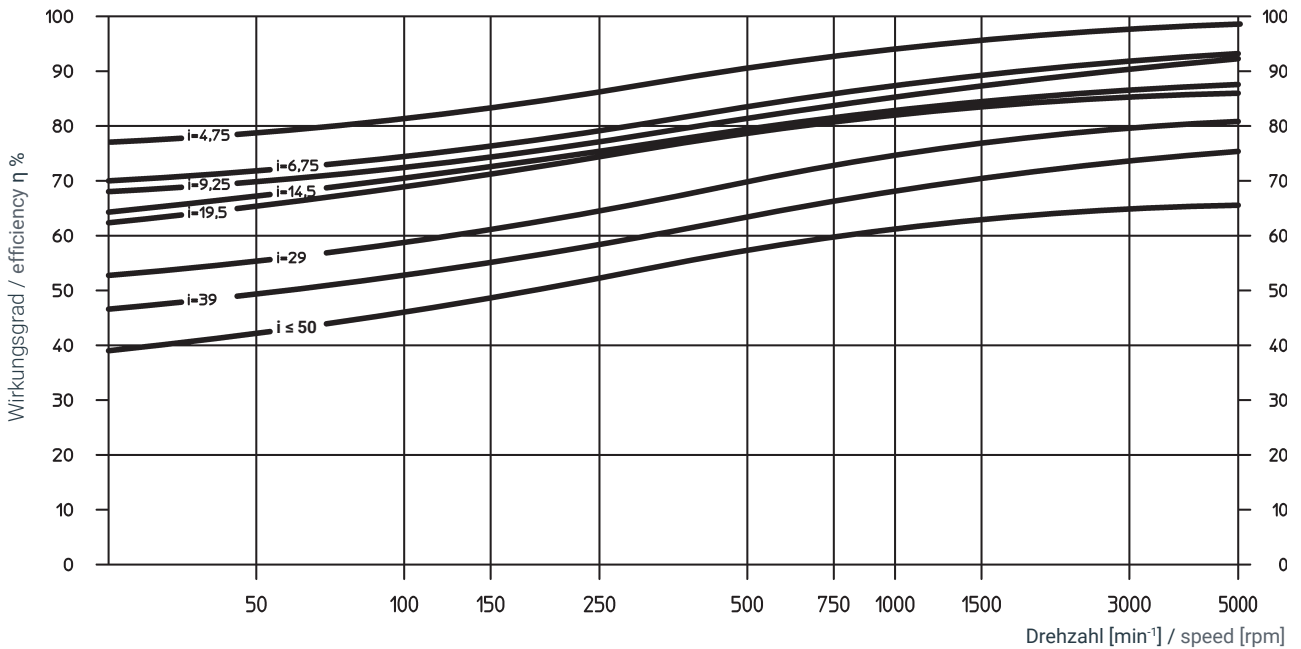

Zusatzbelastungen Abtrieb

Die Angaben sind Richtwerte. Aus der Verzahnung sich ergebende Werte sind zu berücksichtigen. Der Kraftangriff wurde auf Mitte Wellenzapfen angenommen. Treten neben hohen Radialkräften gleichzeitig zusätzliche Axialkräfte auf, bitten wir Sie, bei uns rückzufragen.

Additional loads on output drive

The data given are reference values. You should consider the values arising from the choice of the tooth system. It is assumed that the point of action of the force is the centre of the shaft. In cases where additional axial forces occur, over and above high transverse forces, please ask for advice.

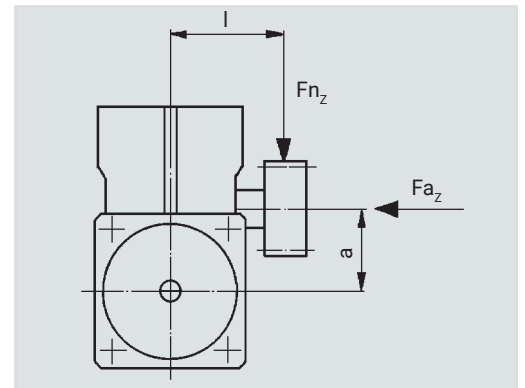

Achsabstand Centre distance	a (mm)	50		63		80		100	
		EN ISO	Klemm- verbind. Clamp Connect.	EN ISO	Klemm- verbind. Clamp Connect.	EN ISO	Klemm- verbind. Clamp Connect.	EN ISO	Klemm- verbind. Clamp Connect.
Maße Mitte Gehäuse / Mitte Verzahnung Dimensions centre casing / centre teeth									
l (mm)		71	105	86	120	103	135	118	162
Max. Zusatzbelastung Max. additional load									
radial F_{n_z}	[N]	6800	4600	9600	7000	15300	11700	17800	13200
radial F_{a_z}	[N]	2700	2700	3800	3800	6000	6000	7500	7500
Nur Axiallast ($F_n=0$) Only axial load	F_{a_z} [N]		5000		8000		15000		3500

Spezialkupplungen für Motor/Getriebe, drehstarre Ausführung, nitriert, vormontiert für Motorwellen ohne Passfeder
Special couplings for motor/gearboxes, rigid model, nitrided, preassembled for motor shafts without key

Bohrung auf Getriebeseite
spielarmes Zahnradprofil
analog DIN 5480 zum Auf-
schieben

Bore on gearbox side
low-clearance tooth-hub
profile corresponding to
DIN 5480 for push-fitting

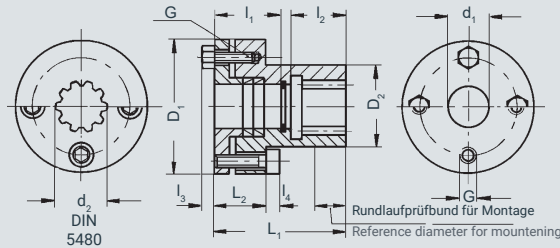

Bohrung auf Motorseite
mit Spannelementen
als Klemm-Verbindung

Bore on motor side with locking
elements as clamp connection

Bestell-Nr. / Order code

Kupplung

Coupling	1)	d ₁	d ₂	D ₁	D ₂	l ₁	l ₂	l ₃	l ₄	L ₁	L ₂	G	J _{red} 10 ⁴ kg m ²	kg
65 43 110	9 71 80 010	10	15x1,25x10	48	29	22	17	-	5	44	18	4xM5	0,835	0,40
65 43 111	9 71 80 011	11	15x1,25x10	48	29	20,5	17	-	5	64	18	4xM5	0,976	0,50
65 43 114	9 71 80 014	14	15x1,25x10	48	29	24	19	-	5	50	18	4xM5	0,835	0,45
65 43 116	9 71 80 016	16	15x1,25x10	48	29	27	16	-	5	50	18	4xM5	0,824	0,45
65 43 119	9 71 80 019	19	15x1,25x10	48	29	24	16	-	5	40	18	4xM5	0,799	0,40
65 43 914	9 71 80 014	14	15x1,25x10	48	29	26	19	-	5	64	18	4xM5	0,985	0,50
65 43 916	9 71 80 016	16	15x1,25x10	48	29	27	15	-	5	64,3	18,3	4xM5	0,975	0,40
65 43 919	9 71 80 019	19	15x1,25x10	48	29	23	17	-	5	55	18	4xM5	0,853	0,45
65 43 924	9 71 80 024	24	15x1,25x10	50	29	34	22	-	6	56	40	4xM6	1,041	0,52
65 44 024	9 71 80 024	24	25x1,25x18	50	29	41,5	24	-	6	66,5	59,5	4xM6	2,628	0,75
65 44 114	9 71 80 014	14	25x1,25x18	55	32	24	23,5	-	6	64	21	4xM6	1,645	0,50
65 44 116	9 71 80 016	16	25x1,25x18	55	32	34	23,5	-	6	64	21	4xM6	1,622	0,50
65 44 119	9 71 80 019	19	25x1,25x18	55	32	33	26,5	-	6	63	21	4xM6	1,598	0,50
65 44 120	9 71 80 020	20	25x1,25x18	55	32	33,2	26,5	-	6	63	21	4xM6	1,550	0,50
65 44 219	9 71 80 019	19	25x1,25x18	55	32	27	26,5	-	6	74	21	4xM6	1,703	0,50
65 44 919	9 71 80 019	19	25x1,25x18	55	32	31	26,5	-	6	78	21	4xM6	1,757	0,55
65 44 928	9 71 80 028	28	25x1,25x18	70	48	48	26	-	6	83	25	5xM6	5,998	0,85
65 44 932	9 71 80 032	32	25x1,25x18	70	48	43	23	-	6	78	25	5xM6	5,921	0,80
65 44 935	9 71 81 035	35	25x1,25x18	70	48	52	26	-	6	78	25	5xM6	6,155	0,95
65 46 024	9 71 80 024	24	38x1,25x29	55	-	38,5	31	4	6	72,5	-	5xM6	4,452	0,90
65 46 834	9 71 81 035	1 3/8"	38x1,25x29	80	58	63	34	-	6	100	40	6xM6	16,320	1,95
65 46 928	9 71 80 028	28	38x1,25x29	70	48	47	34	-	6	90	25	5xM6	5,882	0,90
65 46 932	9 71 80 032	32	38x1,25x29	70	48	43	34	-	6	86	25	5xM6	5,784	0,85
65 46 935	9 71 81 035	35	38x1,25x29	80	58	65	34	-	6	100	40	6xM6	16,550	1,95
65 46 938	9 71 80 038	38	38x1,25x29	80	58	62	34	-	6	100	40	6xM6	16,240	1,88
65 47 948	9 71 80 048	48	38x1,25x29	95	66	58	31	-	8	92	42	6xM8	41,860	3,10

1) Ersatzteil Spannelement / Spare part clamping element

Um eine entsprechende Spielfreiheit und maximale Kraftübertragung zu gewährleisten, erfolgt die Verbindung zwischen unseren Servo-Schneckengetrieben und einem Antriebsmotor durch eine Spezialkupplung, deren Innenverzahnung zusammen mit der Antriebswelle der Getriebe dem Zahnradprofil analog DIN 5480 entspricht.

To ensure a corresponding freedom from backlash and maximum power transmission, the connection between our servo worm gearboxes and a drive motor is made by a special coupling, the internal teeth of which, together with the drive shaft of the gearbox, correspond to the gear hub profile analogous to DIN 5480.



Schrumpfscheiben-Spannsätze für Abtriebswellen und Zahnräder mit geschliffener Verzahnung Shrink-disc clamping sets for output drive shafts and gearwheels with ground teeth

Lieferung erfolgt als kompletter Satz
Supplied as complete set

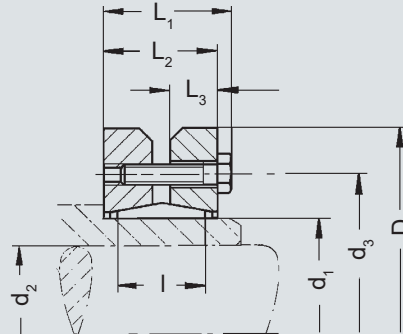

$$J_{\text{red}} = \frac{J}{i^2}$$

Bestell-Nr. Order code	Getriebe / Gearbox HT	a ₀ mm HP/E	T ₂ max Nm	d ₁	d ₂	d ₃	D	L ₁	L ₂	L ₃	l	G	J _{red} 10 ⁻⁴ kg m ²	kg
80 81 024	x	32	270	20	24	36	50,2	23,0	19,5	7,60	14,0	5 x M5	0,780	0,2
80 83 030	x	50	400	25	30	44	60,2	25,0	21,5	9,00	18,0	7 x M5	1,756	0,3
			200	19										
			130	16										
80 84 036	50	63	540	28	36	52	72,2	27,5	23,5	10,00	22,5	5 x M6	4,029	0,4
			270	22										
80 85 050	63	80	1350	38	50	72	90,2	31,5	27,5	12,00	22,0	9 x M6	11,322	0,8
			1180	36										
			870	32										
			730	30										
80 86 062	80	100	2300	48	62	89	110,2	34,5	30,5	13,00	22,0	12 x M6	27,137	1,3
			1420	40										
80 87 080	100	125	3240	60	80	100	145,3	38,0	32,5	14,00	22,0	7 x M8	88,870	1,9
			2580	55										

x) Für Getriebe nicht geeignet / not suitable for gearboxes

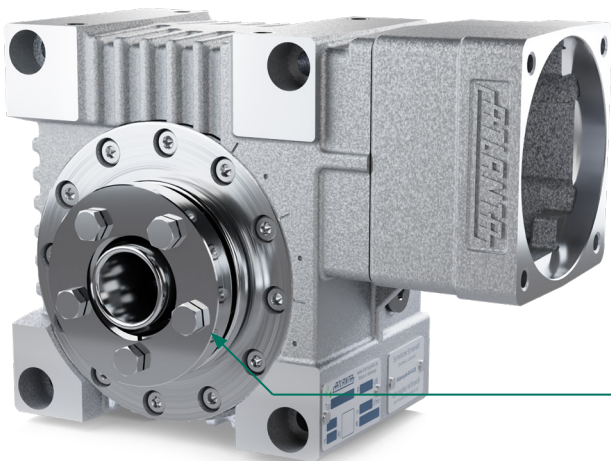

Schrumpfscheibe als Spannsatz
passend für jede Hohlwelle
Shrink-disc as clamping-set for each
size of hollow shaft