

Control Box

DKC3

DKC3 is designed for electrical lifting desk, table and height adjustable work station, which is able to perform smooth synchronized or single motor movement. It also supports real-time height display and position memory function.



Feature

- Main applications: Furniture
- Input voltage: 100 ~ 240V AC, 50/60Hz (SMPS)
- Output voltage: 24V DC / 32V DC
- Max. current: 4.5A for 24V or 6A for 32V, per channel
- Power supply: Internal SMPS, 24V/4A or 32V/4A
- Max. number of motors / actuators: 2 channels (synchronization)
- Max. number of controls: 1 channel
- Real-time height display
- Position memory function
- Soft start / stop function
- Anti-pinch function (draw back automatically while detecting resistance)
- Duty cycle: 10%, max. 2 min. continuous operation in 20 min.
- IP Protection level: IP20
- Protection class: Class II
- Color: Black
- Power cord length: 3000 mm
- Certified: CE Marking, EMC Directive 2014/30/EU and LVD Directive 2014/35/EU

Compatibility

Product	Model	Compatible requirement
Motor / Actuator	DLC2 Lifting column DKL3 Desk lifting column DKM4-LF Gear motor FD60-24-A4 Actuator	With dual Hall effect sensors With Moteck L1-type minifit 6-pin plug
Control	DKP3	Moteck S2 control category With Moteck E-type RJ 10-pin plug
	DKP4	Moteck P2 control category Max. 2 buttons With Moteck E-type RJ 10-pin plug

Dimensions

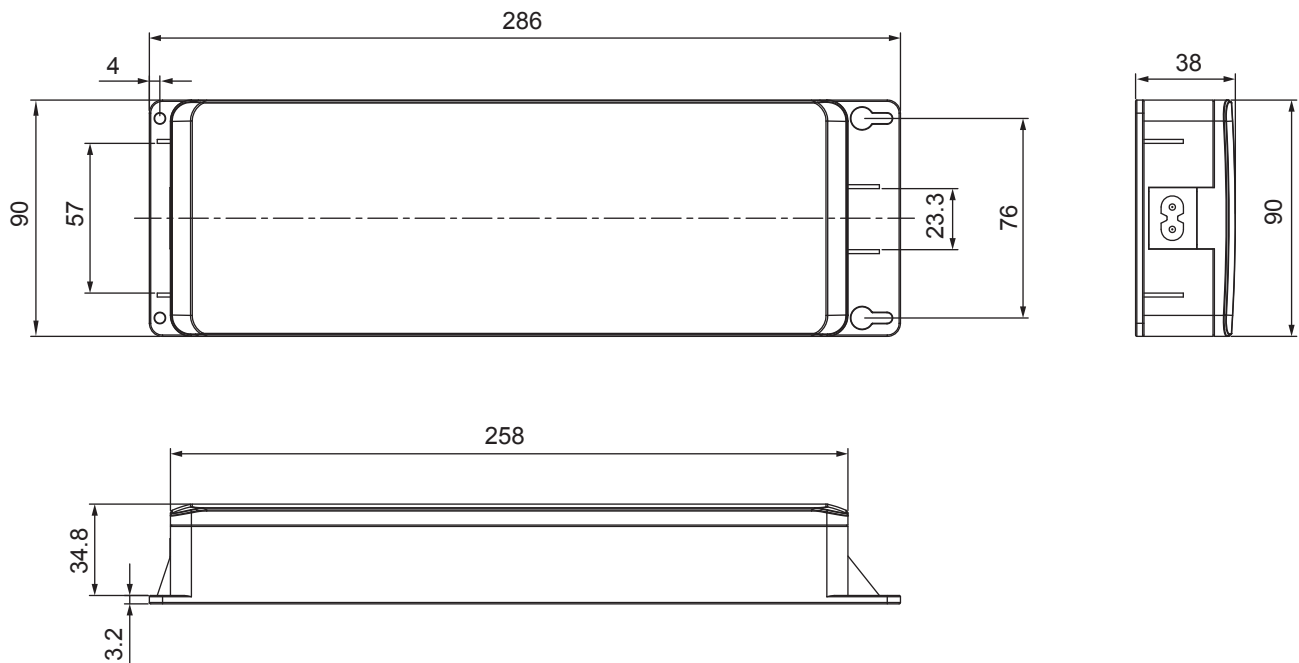

I/O Introduction

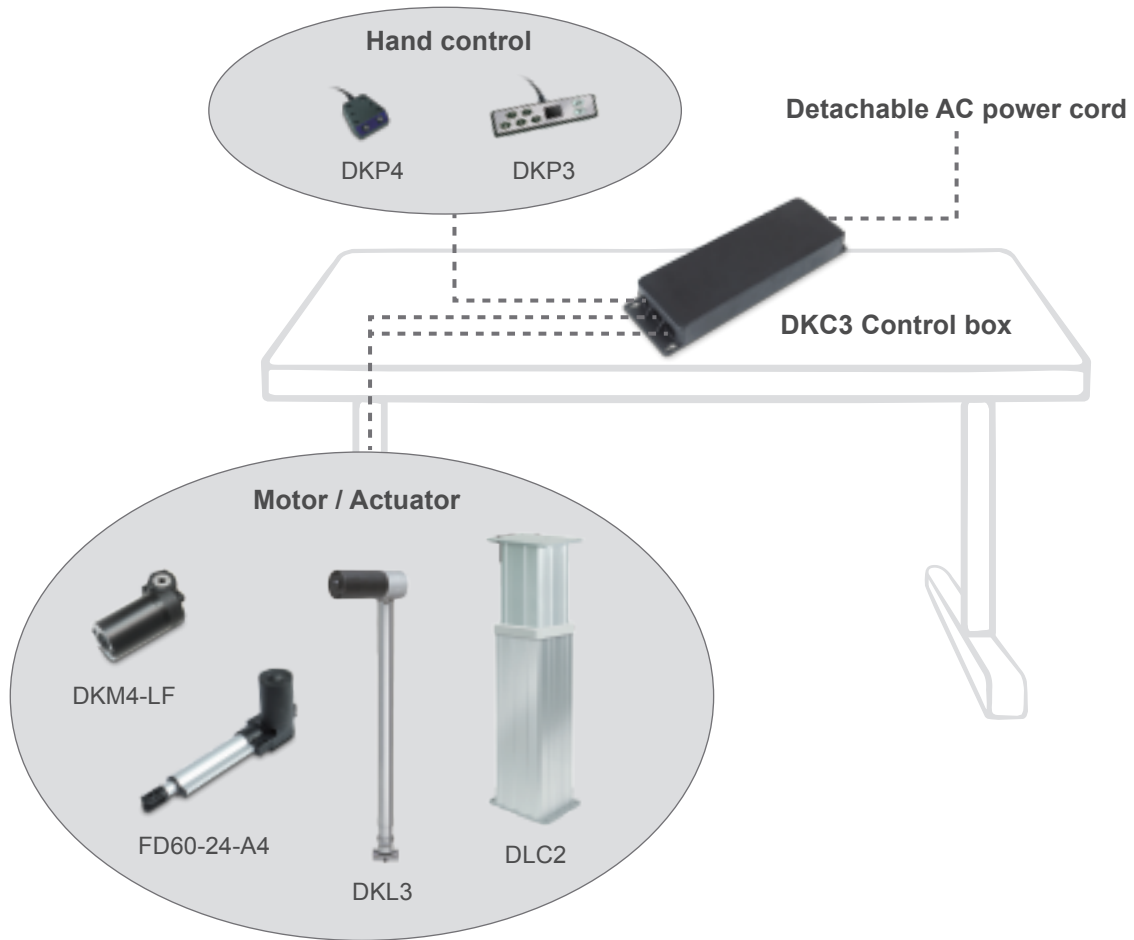

Socket

Actuator socket for L1-type minifit 6-pin, 180° plug

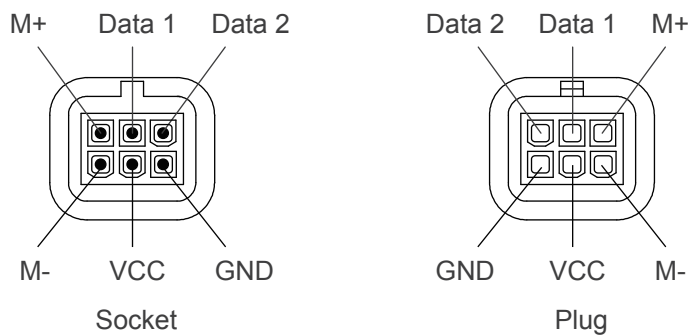

Control socket for E-type RJ 10-pin plug

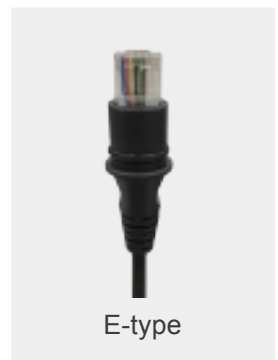

Ordering Key

DKC3 - 24 - 2

Output voltage	24: 24V DC 32: 32V DC
Number of motor	1: 1 channel 2: 2 channels



Note:

1. Please contact sales for software parameters adjustment according to required function and characteristics of actuator/legs used.
2. Refer to data sheets of compatible controls for operating guide.

Terms of Use

The user is responsible for application suitability of Moteck products. As ongoing improvement process continues, products listed on the Moteck website are subject to change without prior notice. Moteck reserves the right to terminate the sales or remove any product displayed on the website, or listed in its catalogues.