

Sprzęgła

Sprzęgła kłowe elastyczne

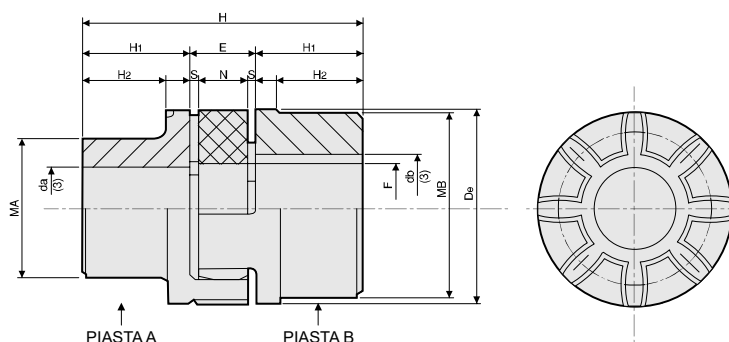

Materiał: żeliwo EN-GJL-250 UNI EN 1561

kod		typ/ rozmiar	otwór pilotażowy A, B	max. otwór da piasta A	max. otwór db piasta B	H ₁	De	E	F	MA	MB	N	H ₂	S	H	[kg]	
piasta A	piasta B															A	B
SP0001	SP0011	19A-24B*	6	19	24	25	40	16	18	30	40	12	19,0	2,0	66	0,18	0,25
SP0002	SP0012	24A-32B	9	24	32	30	55	18	27	40	55	14	24,0	2,0	78	0,36	0,55
SP0003	SP0013	28A-38B	10	28	38	35	65	20	30	48	65	15	27,5	2,5	90	0,60	0,85
SP0004	SP0014	38A-45B	12	38	45	45	80	24	38	66	78	18	36,5	3,0	114	1,35	1,65
SP0005	SP0015	42A-55B	12	42	55	50	95	26	46	75	94	20	40,0	3,0	126	2,00	2,30
SP0006	SP0016	48A-60B	12	48	60	56	105	28	51	85	104	21	45,0	3,5	140	2,75	3,10
SP0007	SP0017	55A-70B	15	55	70	65	120	30	60	98	118	22	52,0	4,0	160	4,20	4,50
SP0008	SP0018	65A-75B	15	65	75	75	135	35	68	115	134	26	61,0	4,5	185	6,50	6,80
SP0009	SP0019	75A-90B	15	75	90	85	160	40	80	135	158	30	69,0	5,0	210	10,00	10,80
SP0010	SP0020	90A-100B	38	90	100	100	200	45	100	160	180	34	81,0	5,5	245	14,00	15,80

*Dostępne wykonanie w materiale STAL.

Materiał: aluminium

kod		typ/ rozmiar	otwór pilotażowy A, B	max. otwór da piasta A	max. otwór db piasta B	H ₁	De	E	F	MA	MB	N	H ₂	S	H	[kg]	
piasta A	piasta B															A	B
SP00 1	SP0025	19A-24B/AL	6	19	24	25	40	16	18	30	40	12	19,0	2,0	66	0,07	0,08
SP0022	SP0026	24A-32B/AL	9	24	32	30	55	18	27	40	55	14	24,0	2,0	78	0,13	0,18
SP0023	SP0027	28A-38B/AL	10	28	38	35	65	20	30	48	65	15	27,5	2,5	90	0,22	0,30
SP0024	SP0028	38A-45B/AL	12	38	45	45	80	24	38	66	78	18	36,5	3,0	114	0,48	0,55

*Na życzenie klienta dostarczamy piasty z otworami wg standardów ISO, tolerancji H7 oraz rowkiem wg DIN 6885 w tolerancji JS9.

Sprzęgła

Sprzęgła kłowe pod tuleje zaciskowe TAPER LOCK

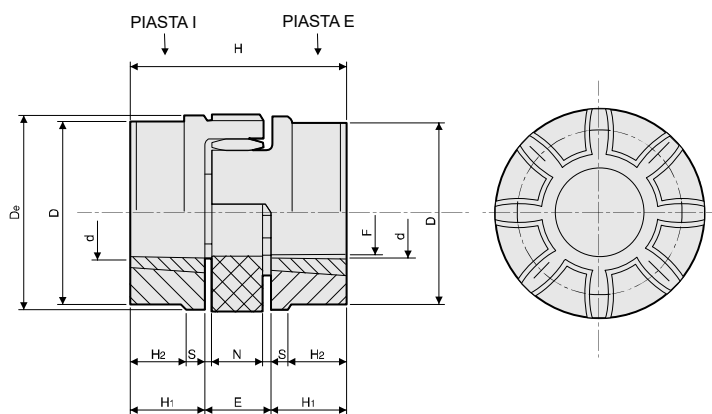

Materiał: żeliwo EN-GJL-250 UNI EN 1561

kod		typ/ rozmiar	otwór d min	otwór d max	tuleja	H ₁	D _e	E	F	D	N	S	H	H ₂	[kg]	
piasta I	piasta E														I	E
SP0029	SP0035	28-38 TL	9	28	1108	23	65	20	30	65	15	2,5	66	-	0,50	0,50
SP0030	SP0036	38-45 TL	9	28	1108	23	80	24	38	78	18	3,0	70	15	0,88	0,88
SP0031	SP0037	42-55 TL	10	42	1610	26	95	26	46	94	20	3,0	78	16	1,40	1,40
SP0032	SP0038	48-60 TL	10	42	1615	39	105	28	51	104	21	3,5	106	28	2,33	2,33
SP0033	SP0039	55-70 TL	12	50	2012	33	120	30	60	118	22	4,0	96	20	2,42	2,42
SP0034	SP0040	75-90 TL	16	60	2517	52	160	40	80	158	30	5,0	144	36	6,80	6,80

Sprzęgła

Wkładka sprzęgła kłowego

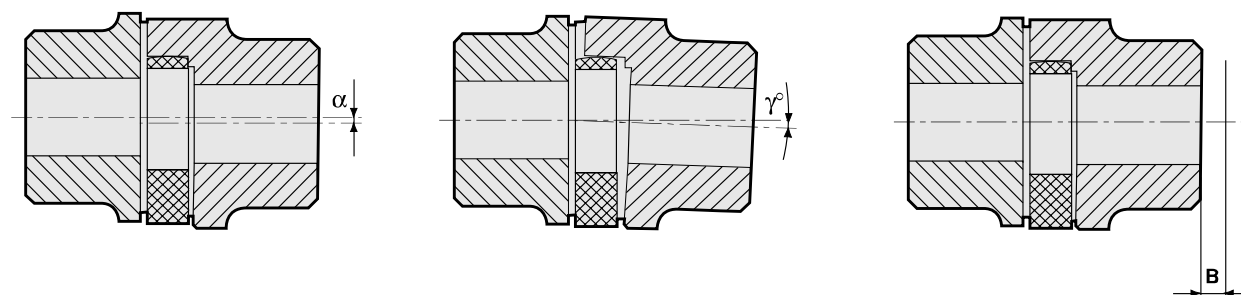

Wkładka żółta 92 SHORE

kod	typ/ rozmiar	Max rpm	kąt skręcania przy		twardość	moment obrotowy (Nm)			dynamiczna sztywność skrętna (kNm/rad)				B mm	max. przesunięcie radialne	max. wychylenie kątowe
			TKN	Tkmax		nominalny TKN	maksymalny Tkmax	zmienny TKW	1,0 TKN	0,75 TKN	0,5 TKN	0,25 TKN			
SP0041	19/24	14000	3,2°	5°	92	10	20	2,6	1,28	1,05	0,80	0,47	1,2	0,20	1,2°
SP0042	24/32	10600	3,2°	5°	92	35	70	9,1	4,86	3,98	3,01	1,79	1,4	0,22	0,9°
SP0043	28/38	8500	3,2°	5°	92	95	190	25,0	10,90	8,94	6,76	4,01	1,5	0,25	0,9°
SP0044	38/45	7100	3,2°	5°	92	190	380	49,0	21,05	17,26	13,05	7,74	1,8	0,28	1,0°
SP0045	42/55	6000	3,2°	5°	92	265	530	69,0	23,74	19,47	14,72	8,73	2,0	0,32	1,0°
SP0046	48/60	5600	3,2°	5°	92	310	620	81,0	36,70	30,09	22,75	13,49	2,1	0,36	1,1°
SP0047	55/70	4750	3,2°	5°	92	410	820	107,0	50,72	41,59	31,45	18,64	2,2	0,38	1,1°
SP0048	65/75	4250	3,2°	5°	92	625	1250	163,0	97,13	79,65	60,22	35,70	2,6	0,42	1,2°
SP0049	75/90	3550	3,2°	5°	92	1280	2560	333,0	113,32	92,92	70,26	41,65	3,0	0,48	1,2°
SP0050	90/100	2800	3,2°	5°	92	2400	4800	624,0	190,09	155,87	117,86	69,86	3,4	0,50	1,2°

Wkładka czarna 94 SHORE

kod	typ/ rozmiar	Max rpm	kąt skręcania przy		twardość	moment obrotowy (Nm)			dynamiczna sztywność skrętna (kNm/rad)				B mm	max. przesunięcie radialne	max. wychylenie kątowe
			TKN	Tkmax		nominalny TKN	maksymalny Tkmax	zmienny TKW	1,0 TKN	0,75 TKN	0,5 TKN	0,25 TKN			
SP0051	19/24	14000	3,2°	5°	94	12	24	3,2	1,82	1,49	1,13	0,67	1,2	0,20	1,2°
SP0052	24/32	10600	3,2°	5°	94	43	86	11,4	6,55	5,36	4,06	2,41	1,4	0,22	0,9°
SP0053	28/38	8500	3,2°	5°	94	126	233	30,6	16,19	13,27	10,04	5,95	1,5	0,25	0,9°
SP0054	38/45	7100	3,2°	5°	94	235	470	61,0	30,22	24,78	18,73	11,11	1,8	0,28	1,0°
SP0055	42/55	6000	3,2°	5°	94	326	653	85,0	33,99	27,87	21,07	12,49	2,0	0,32	1,0°
SP0056	48/60	5600	3,2°	5°	94	381	763	99,7	46,23	37,90	28,64	16,99	2,1	0,36	1,1°
SP0057	55/70	4750	3,2°	5°	94	500	1003	130,7	65,47	53,68	40,59	24,06	2,2	0,38	1,1°
SP0058	65/75	4250	3,2°	5°	94	730	1460	190,0	107,92	88,50	66,91	39,66	2,6	0,42	1,2°
SP0059	75/90	3550	3,2°	5°	94	1493	2986	388,3	141,38	115,93	87,65	51,96	3,0	0,48	1,2°
SP0060	90/100	2800	3,2°	5°	94	2800	5600	728,0	230,79	189,24	143,09	84,81	3,4	0,50	1,2°

Wkładka czerwona 98 SHORE

kod	typ/ rozmiar	Max rpm	kąt skręcania przy		twardość	moment obrotowy (Nm)			dynamiczna sztywność skrętna (kNm/rad)				B mm	max. przesunięcie radialne	max. wychylenie kątowe
			TKN	Tkmax		nominalny TKN	maksymalny Tkmax	zmienny TKW	1,0 TKN	0,75 TKN	0,5 TKN	0,25 TKN			
SP0061	19/24	14000	3,2°	5°	98	17	34	4,4	2,92	2,39	1,81	1,07	1,2	0,20	1,2°
SP0062	24/32	10600	3,2°	5°	98	60	120	16,0	9,93	8,14	6,16	3,65	1,4	0,22	0,9°
SP0063	28/38	8500	3,2°	5°	98	160	320	42,0	26,77	21,95	16,60	9,84	1,5	0,25	0,9°
SP0064	38/45	7100	3,2°	5°	98	325	650	85,0	48,57	39,83	30,11	17,85	1,8	0,28	1,0°
SP0065	42/55	6000	3,2°	5°	98	450	900	117,0	54,50	44,69	33,79	20,03	2,0	0,32	1,0°
SP0066	48/60	5600	3,2°	5°	98	525	1050	137,0	65,29	53,54	40,48	24,00	2,1	0,36	1,1°
SP0067	55/70	4750	3,2°	5°	98	685	1370	178,0	94,97	77,88	58,88	34,90	2,2	0,38	1,1°
SP0068	65/75	4250	3,2°	5°	98	940	1880	244,0	129,51	106,20	80,30	47,60	2,6	0,42	1,2°
SP0069	75/90	3550	3,2°	5°	98	1920	3840	499,0	197,50	161,95	122,45	72,58	3,0	0,48	1,2°
SP0070	90/100	2800	3,2°	5°	98	3600	7200	936,0	312,20	256,00	193,56	114,73	3,4	0,50	1,2°

Sprzęgła

Tabela doboru sprzęgieł do silników elektrycznych (łącznik żółty 92 SHORE)

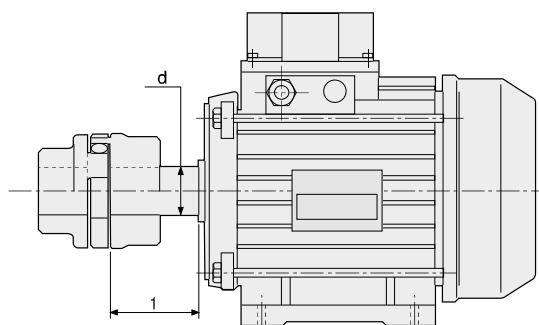

typ silnika	3000 [1/min]				1500 [1/min]				1000 [1/min]				750 [1/min]				dxl [mm]
	P (kW)	T (Nm)	typ/rozmiar sprzęgła	Fs	P (kW)	T (Nm)	typ/rozmiar sprzęgła	Fs	P (kW)	T (Nm)	typ/rozmiar sprzęgła	Fs	P (kW)	T (Nm)	typ/rozmiar sprzęgła	Fs	
	0,75	2,4		8,0	0,55	3,6		5,4	0,37	3,6		5,1	0,18	2,3		8,0	
80											19/24				19/24		19 x 40
	1,1	3,6		5,4	0,75	4,9		3,9	0,55	5,4		3,4	0,25	3,2		5,7	
90 S	1,5	4,9	19/24	4,0	1,1	7,6	19/24	2,7	0,75	7,3		2,5	0,37	4,8		3,8	24 x 50
90 L	2,2	7,2		2,7	1,5	9,8		2,0	1,1	10,8		5,8	0,55	7,2		2,5	
					2,2	14,4		4,7					0,75	9,8		6,4	
100 L	3,0	9,8		7,1					1,5	14,7		4,7					
					3,0	19,6		3,5					1,1	14,4		4,4	28 x 60
112 M	4,0	13,1	28/32	5,4	4,0	26,2	24/32	2,6	2,2	21,6	24/32	3,2	1,5	19,7	24/32	3,3	
	5,5	18,0		10,6													
132 S					5,5	36,0		5,3	3,0	29,5		6,3	2,2	28,8		6,6	
	7,5	24,6		7,6													38 x 38
			24/38				28/38		4,0	39,0	28/38	4,8			28/38		
132 M					7,5	49,0		3,9					3,0	39,0		4,8	
									5,5	54,0		3,5					
	11,0	36,0		10,6									4,0	52,0		7,0	
160 M					11,0	72,0		5,3	7,5	73,0		5,1					
	15,0	49,0		7,8									5,5	72,0		5,1	42 x 110
160 L	18,0	60,0	38/45	6,3	15,0	98,0	38/45	3,9	11,0	108,0	38/45	3,5	7,5	98	38/45	3,8	
180 M	22,0	72,0		7,5	18,5	121,0		4,4									48 x 110
180 L					22,0	144,0		3,7	15,0	147,0		3,6	11,0	144,0		3,7	
	30,0	98,0		5,5			42/55		18,5	182,0	42/55	2,9			42/55		
200 L					30	196		2,7					15,0	197,0		2,7	
	37,0	121,0	42/55	4,4					22,0	216,0		2,5					
225 S					37,0	242,0		2,6					18,5	242,0		2,5	
225 M	45,0	147,0		3,7	45,0	295,0	48/60	2,1	30,0	295,0	48/60	2,1	22,0	288,0	48/60	2,1	55x110 60x140
250 M	55,0	180,0	48/60	3,5	55,0	360,0	55/70	2,1	37,0	364,0	55/70	2,1	30,0	394,0	65	2,2	60 x 140 65 x 140
280 S	75,0	246,0		3,1	75,0	492,0		4,0	45,0	442,0		4,4	37,0	485,0		4,0	75 x 140
280 M	90,0	295,0	55/70	2,6	90,0	590,0	75	3,4	55,0	541,0	75	3,6	45,0	591,0	75	3,3	
315 S	110,0	360,0		2,1	110,0	721,0		2,8	75,0	738,0		2,7	55,0	722,0	75/90	2,7	
315 M	132,0	433,0		4,6	132,0	866,0	75/90	2,3	90,0	885,0	75/90	2,3					65 x 140 80 x 170
	160	525,0		3,8	160,0	1030,0		4,7	110,0	1070,0		4,5	90	1170,0		4,1	
315 L			75/90				90				90				90		
	200,0	656,0		3,0	200,0	1290,0		3,7	132,0	1280,0		3,8	110,0	1420,0		3,4	
	250,0	820,0	75/90	2,4	250,0	1610,0		3,0	160,0	1550,0	90/100	3,1	132,0	1710,0	70/100	2,8	
355 L							90/100	2,4	200,0	1930,0		2,5	160,0	2070,0		3,2	75 x 140 95 x 170
	315,0	1010,0		4,8	315,0	2020,0			250,0	2420,0	100	2,7	200,0	2580,0	100	2,6	
	355,0	1140,0		4,2	355,0	2280,0		2,9									
400 L			90/100	3,8			100		315,0	3040,0							80 x 170 100 x 210
	400,0	1280,0			400,0	25,60		2,6									